



*Member of the FM Global Group*

# **Examination Standard for Controllers for Electric Motor Driven and Diesel Engine Driven Fire Pumps**

**Class Number 1321/1323**

**October 2024**

---

# Foreword

This standard is intended to verify that the products and services described will meet stated conditions of performance, safety and quality useful to the ends of property conservation. The purpose of this standard is to present the criteria for examination of various types of products and services.

Examination in accordance with this standard shall demonstrate compliance and verify that quality control in manufacturing shall ensure a consistent and reliable product.

---

# TABLE OF CONTENTS

<b>1 INTRODUCTION</b> .....	<b>1</b>
1.1 Purpose.....	1
1.2 Scope.....	1
1.3 Basis for Requirements .....	3
1.4 Basis for Certification .....	4
1.5 Basis for Continued Certification .....	4
1.6 Effective Date.....	4
1.7 System of Units .....	4
1.8 Normative References .....	5
1.9 Terms and Definitions .....	7
<b>2 GENERAL INFORMATION</b> .....	<b>14</b>
2.1 Product Information .....	14
2.2 Certification Application Requirements.....	16
2.3 Requirements for Samples for Examination.....	17
<b>3 GENERAL REQUIREMENTS</b> .....	<b>18</b>
3.1 Review of Documentation.....	18
3.2 Design and Functional Features .....	18
3.3 Markings .....	31
3.4 Calibration.....	37
3.5 Tolerances .....	37
<b>4 CONSTRUCTIONAL, FUNCTIONAL AND PERFORMANCE REQUIREMENTS</b> .....	<b>38</b>
4.1 Constructional Requirements For Type Tested Devices For Electric Motor And Diesel Engine Fire Pump Controllers .....	38
4.2 Functional And Performance Requirements For Components .....	45
4.3 Priority Of Manual And Automatic Operations For Electric Fire Pump Controllers .....	51
4.4 Functional And Performance Requirements For Electric Controllers .....	53
4.5 High Voltage Fire Pump Controllers (Rated Over 600 Volts) .....	59
4.6 Fire Pump Motor Characteristics.....	61
4.7 Diesel Engine Fire Pump Controllers.....	67
4.8 Automatic Operation Of A Diesel Engine Drive Controller – Pressure Actuated.....	73
4.9 Automatic Operation Of A Diesel Engine Drive Controller – Non-Pressure Actuated .....	73
4.10 Method Of Starting Of A Diesel Engine Drive Controller, Pressure Actuated And Non-Pressure Actuated.....	73
4.11 Methods Of Stopping Diesel Engine Fire Pump Controllers .....	73
4.12 Field Testing Of Diesel Engine Fire Pump Controllers.....	74
4.13 Additional Functional And Performance Requirements For Positive Displacement Additive/Foam Pump Controllers.....	75
4.14 Variable Speed Electric Motor Driven Fire Pump Controllers.....	76
4.15 EMC Requirements .....	87
<b>5 PERFORMANCE TESTING REQUIREMENTS</b> .....	<b>88</b>
5.1 Type Tests .....	88
5.2 Compliance With Construction Requirements .....	88
5.3 Compliance With Performance Requirements .....	88
5.4 Degree Of Protection Of Enclosure.....	90
5.5 Temperature-Rise Test .....	90
5.6 Dielectric Voltage Withstand Test .....	93
5.7 Short Circuit Test .....	94
5.8 Dielectric Voltage-Withstand Test For Post Short Circuit Testing .....	96

---

5.9	Pressure Switch/Pressure Transducer Tests .....	96
5.10	Verification of Performance under Normal Conditions .....	98
5.11	Controller Phase Calibration .....	100
5.12	Verification of Operating Limits .....	101
5.13	Verification of performance for Variable Speed Electric Motor Driven Fire Pump Controllers ..	102
5.14	Locked Rotor Overcurrent Protection Test (Locked-Rotor Withstand Current Test) .....	102
5.15	Barrier Dielectric Strength Test.....	103
5.16	Printed Circuit Board Coating Performance Test.....	103
5.17	Verification of capability of battery chargers (for diesel engine fire pump controllers only) .....	105
5.18	EMC .....	107
<b>6</b>	<b>MANUFACTURER'S REQUIREMENTS.....</b>	<b>110</b>
6.1	Demonstrated Quality Control Program.....	110
6.2	Surveillance Audit.....	111
6.3	Product Modifications .....	111
<b>7</b>	<b>BIBLIOGRAPHY.....</b>	<b>112</b>
<b>Appendix A: Tables .....</b>		<b>113</b>
<b>Appendix B: Figures.....</b>		<b>126</b>
<b>Appendix C: .....</b>		<b>137</b>
<b>Appendix D: Electromagnetic compatibility .....</b>		<b>138</b>
<b>Appendix E: NEMA Enclosure Types .....</b>		<b>141</b>
<b>Appendix F:.....</b>		<b>148</b>
<b>Appendix G: Tolerance .....</b>		<b>149</b>
<b>Appendix H: Sample Listing.....</b>		<b>150</b>

# 1 INTRODUCTION

## 1.1 Purpose

- 1.1.1 This standard states testing and certification requirements for electric motor and diesel engine driven fire pump controllers that start, control, monitor, and stop pump drivers for fire protection systems. These controllers must have an extended service life, throughout which they must be capable of operating reliably during emergency fire incidents, despite being idle for extended periods.
- 1.1.2 Testing and certification criteria may include structural features, performance requirements, marking requirements, examination of manufacturing facility(ies), audit of quality assurance procedures, and a surveillance program.

## 1.2 Scope

- 1.2.1 This standard encompasses the design and performance requirements for controllers for electric motor driven and diesel engine driven fire pumps used in fire pump service that are designed and installed in accordance with the applicable documents listed in Section 1.8. The intended operation of a fire pump controller is to initiate and sustain the operation of the fire pump driver in the event of a fire. In addition, controllers are tested under specified overload and fault conditions. To this extent the fire pump controller is unique when compared to other industrial motor controllers, and system reliability is improved by provisions for self testing and annunciation of conditions that could result in fire protection impairment.
- 1.2.2 This standard applies to controllers intended for starting, controlling and stopping stationary, centrifugal and positive displacement, fire pumps, including automatic and non-automatic types for alternating current electric motor or diesel engine driven fire pumps. For the purpose of this standard, the term “controller” indicates a full service controller. Types of controllers covered include diesel engine, electric motor, high (medium) voltage, and variable speed. It is anticipated that a controller only controls a single driver. If multiple pumps operate in parallel as a single unit, one controller can control several drivers. It is also anticipated that fire pump controllers submitted for examination and certification by the certification agency will be designed to meet the requirements of this standard which encompasses the requirements of American National Standards Institute (ANSI)/National Fire Protection Association (NFPA) 20, *Standard for the Installation of Stationary Pumps for Fire Protection* and requirements of other leading documents in the area of fire pump controllers and electrical control devices.
  - 1.2.2.1 Controllers for electric motor driven, centrifugal fire pumps are intended for use with squirrel cage induction motors or wound rotor induction motors rated 600V or less. Controllers for squirrel cage induction motors may be for across-the-line or reduced inrush starting. Controllers may be provided with integral automatic transfer switches. The design and construction of controllers for electric motor driven fire pumps shall be for use with fire pump motors specified in ANSI/NFPA 20, *Standard for the Installation of Stationary Pumps for Fire Protection*, or the International Electrotechnical Commission (IEC) Standard IEC34-1. As a minimum, the controllers shall be suitable for National Electrical Manufacturers Association (NEMA) design “B” motors, as defined in NEMA standard MG-1, *Motors and Generators Revision 2*. Controllers shall be suitable for motor starting codes “F” or “G” (per NEMA MG-1) for motors at or above 15 hp (11 kW). Large horsepower motors, those in excess of 500 hp (375 kW), are not required to comply with NEMA MG-1. These large motors are allowed to exceed the horsepower and locked rotor current designations for NEMA design “B” motors as specified in ANSI/NFPA 20. The associated fire pump controller must be designed accordingly.
  - 1.2.2.2 Limited service controllers are not certified devices however the following is provided as reference for the reader since these devices do exist within the fire protection community. Limited service controllers are automatic controllers intended for across-the-line starting of

squirrel cage induction motors rated 30 hp (20 kW) or less, and 600V or less. Limited service controllers may be provided with integral automatic transfer switches. Limited service controllers are intended for use with limited service pumps and were originally accepted by ANSI/NFPA 20 for specific light hazard type occupancies since at the time, full service fire pump controllers were not designed for less than 20 hp (15 kW) rated motors. Since many controller manufacturers now provide full service fire pump controllers for motors rated less than 20 hp (15 kW), there is no longer any need for limited service devices.

- 1.2.2.3 High voltage fire pump controllers (also referred to as medium voltage) are intended for use with squirrel cage induction motors rated 601V - 7.2 kV A.C. This upper range may vary by country and jurisdiction.
- 1.2.2.4 Diesel engine fire pump controllers rated nominal 24V D.C. or less are intended for use with fire pump engines, and for use with A.C. power supplies (mains) on branch circuits of 600 V A.C. or less rated for 50 Hz or 60 Hz, or both.
- 1.2.2.5 Variable speed fire pump controllers for electric motor driven, centrifugal fire pumps are intended for use with squirrel cage induction, inverter duty rated, motors rated 600V or less, and rated for 50 Hz or 60 Hz. This type of controller uses a variable frequency drive to change the speed of the electric motor and the resultant pressure and flow output of the fire pump in response to feedback from a pressure sensor on the discharge side of the fire pump. The variable speed controller maintains system design pressure by monitoring changes in pressure demand for the fire protection system and adjusting the pump speed according to that demand.
- 1.2.2.6 Variable speed devices for diesel engine drivers are not within the scope of this standard since these devices are not part of the fire pump controller. Variable speed devices for diesel engine drivers are mechanical devices that attach directly to the diesel engine fuel system. The output pressure of the fire pump is changed by controlling the fuel intake governor to the engine. This device is covered in Examination Standard 1333, *Diesel Engine Fire Pump Drivers*. Controllers for use with these diesel engines shall provide the required system overpressure alarm per ANSI/NFPA 20, *Standard for the Installation of Stationary Pumps for Fire Protection*, and shall also include the pressure sensor.
- 1.2.3 Controllers for electric motor driven fire pumps always include suitable short circuit protection as an integral part of the controller. This protection is typically provided by circuit breakers except for high (medium) voltage controllers. These controllers may include an integral power transfer switch. These controllers/automatic power transfer switch combinations are rated 600 V A.C. maximum in North America, and rated 1000 V A.C. maximum in Europe and Asia. Controllers combined with an automatic power transfer switch require two short circuit ratings, one for the “Normal” source power supply, and one for the “Emergency” source alternate power supply. Electric motor driven controllers shall also be suitable for use as service entrance equipment (SUSE) where so used. As such, they are required to be marked with a short circuit rating (Withstand and Interrupt Current Rating).
- 1.2.4 Controllers for diesel engine driven fire pumps include electrical circuits that operate various control and supervisory functions such as remote control (starting), alarms, signals, indicators, and the proper operation of battery chargers.
- 1.2.5 The purpose of this standard is to characterize the unique features of fire pump controllers, prescribe a procedure for exercising the controllers to verify their performance and reliability, and to ensure that effective quality controls are being implemented by the manufacturer to ensure a consistently fabricated and reliable product.

- 1.2.6 The object of this standard is to:
- a. Define the unique characteristics of fire pump controllers, their associated equipment and their operational functions;
  - b. Prescribe the conditions with which fire pump controllers shall comply with reference to:
    1. Their construction;
    2. Their critical components including the mounting, arrangement, wiring and connections;
    3. The degrees of protection provided by their enclosures;
    4. Their modes of actuation;
    5. Their operation and behavior under normal, overload and short circuit conditions;
    6. Their capability to annunciate significant events; and,
    7. Their electromagnetic compatibility for the environment into which they are placed.
  - c. Detail the performance tests for confirming that these conditions have been met, and the methods to be adopted for these tests;
  - d. Identify the information to be provided with the equipment such as markings, labels, drawings and information provided on or within the equipment.
- 1.2.7 In this context, this standard gives the requirements for all of the electrical functions associated with both the electric motor driven and the diesel engine driven fire pumps. Special applications such as explosive atmospheres, nuclear installations, ships, aircraft etc. are not covered by this standard. Referring to electric power sources, the requirements of this standard apply only to the extent that they place limits on the nature, behavior and characteristics of the electrical energy that is supplied to the service entrance (see UL 508 and UL 869A, or IEC 60364-5-55).
- 1.2.8 The requirements of this standard do not apply to the method or means by which the electrical energy is generated nor do they apply to the installation between the origin of the installation and the fire pump controller, which are to be found in ANSI/NFPA 70 NEC or the IEC 60364 series. This standard does not apply to diesel engine driven electric generators which may be associated with a stationary fire pump installation.
- 1.2.9 Electromagnetic Compatibility (EMC) considerations are correlated with other IEC standards for similar products:
- a. For electric fire pump controllers, EMC requirements are covered by this standard; and,
  - b. For diesel engine fire pump controllers, D.C. batteries are the required source of electrical power for starting and monitoring the engine. A.C. (mains) power to the controller is used for battery charging. A.C. (mains) power provided to the controller may also be used for other small devices that have dedicated factory-equipped field terminals and overcurrent protection, such as pump room space heaters, pump room dampers and engine oil heaters, at the discretion of the authority having jurisdiction (AHJ). EMC requirements for diesel engine fire pump controllers are covered by this standard.

### 1.3 Basis for Requirements

- 1.3.1 The requirements of this standard are based on experience, research and testing, and on the standards of other organizations. They are also based on the advice of manufacturers, users, trade associations, jurisdictions and loss control specialists.
- 1.3.2 The requirements of this standard reflect tests and practices used to examine characteristics of fire pump controllers for the purpose of obtaining certification.

#### 1.4 Basis for Certification

Certification is based upon satisfactory evaluation of the product and the manufacturer in the following major areas:

1.4.1 Examination and tests on production samples shall be performed to evaluate:

- the suitability of the product;
- the performance of the product as specified by the manufacturer and required by the certification agency; and,
- the durability and reliability of the product.

1.4.2 An examination of the manufacturing facilities and audit of quality control procedures may be made to evaluate the manufacturer's ability to consistently produce the product which is examined and tested, and the marking procedures used to identify the product. Subsequent surveillance may be required by the certification agency in accordance with the certification scheme to ensure ongoing compliance.

#### 1.5 Basis for Continued Certification

1.5.1 The basis for continual certification may include the following based upon the certification scheme and requirements of the certification agency:

- production or availability of the product as currently certified;
- the continued use of acceptable quality assurance procedures;
- compliance with the terms stipulated by the certification;
- satisfactory re-examination of production samples for continued conformity to requirements; and
- satisfactory surveillance audits conducted as part of the certification agencies product surveillance program.

#### 1.6 Effective Date

The effective date of this certification standard mandates that all products tested for certification after the effective date shall satisfy the requirements of this standard.

The effective date of this standard is eighteen (18) months after the publication date of the standard for compliance with all requirements.

#### 1.7 System of Units

Units of measurement used in this standard are United States (U.S.) customary units. These are followed by their arithmetic equivalents in International System (SI) units, enclosed in parentheses. The first value stated shall be regarded as the requirement. The converted equivalent value may be approximate. Conversion of U.S. customary units is in accordance with ANSI/IEEE/ASTM SI 10.

Two units (liter and bar), outside of but recognized by SI, are commonly used in international fire protection and are used in this standard.



## 1.8 Normative References

The following documents are referred to in the text in such a way that some or all of their content constitutes requirements of this document. For dated references, only the cited edition applies.

ANSI/IEEE C62.1, *Surge Arrestors for Alternating-Current Power Circuits*

ANSI/IEEE C62.11, *Metal-Oxide Surge Arrestors for Alternating Current Power Circuits*

ANSI/IEEE C62.41, *Surge Voltages in Low-Voltage AC Power Circuits*

ANSI/NEMA ICS 2, *Industrial Control and Systems: Controllers, Contactors, and Overload Relays, Rated Not More Than 2000 Volts AC or 750 Volts DC*

ANSI/NEMA 250, *Enclosures for Electrical Equipment (1000 Volts Maximum)*

ANSI/NFPA 20, *Standard for the Installation of Stationary Pumps for Fire Protection*

ANSI/NFPA 70, *National Electric Code*

ANSI/UL 50, *Standard for Enclosures for Electrical Equipment*

ANSI/UL 50E, *Standard for Enclosures for Electrical Equipment, Environmental Considerations*

ANSI/UL 98, *Standard for Enclosed and Dead-Front Switches*

ANSI/UL 218, *Fire Pump Controllers*

ANSI/UL 347, *Standard for Safety for High Voltage Industrial Control Equipment*

ANSI/UL 486A-486B, *Standard for Wire Connectors*

ANSI/UL 486E, *Equipment Wiring Terminals for Use with Aluminum and/or Copper Conductors*

ANSI/UL 489, *Standard for Safety for Molded-Case Circuit Breakers, Molded-Case Switches, and Circuit-Breaker Enclosures*

ANSI/UL 508, *Industrial Control Equipment*

ANSI/UL 508C, *Standard for Safety for Power Conversion Equipment*

ANSI/UL 840, *Standard for Safety for Insulation Coordination Including Clearances and Creepage Distances for Electrical Equipment*

ANSI/UL 1008, *Standard for Transfer Switch Equipment*

ANSI/UL 1059, *Standard for Terminal Blocks*

ASTM D 3874, *Standard Test Method for Ignition of Materials by Hot Wire Source*

Canadian Electrical Code, Part I, *Safety Standard for Electrical Installations*

CSA 22.2 No. 0.12, *Wiring Space and Wire Bending Space in Enclosures*

CSA 22.2 No. 14, *High Voltage Industrial Control Equipment*

FM 1333, *Diesel Engine Fire Pump Drivers*

IEC 60364 (all parts), *Electrical installations of buildings*

IEC 60529, *Degrees of protection provided by enclosures (IP code)*

IEC 60695-11-10, *Fire hazard testing – Part 11-10: Test flames – 50 W horizontal and vertical flame test methods*

IEC 60947-1, *Low-Voltage Switchgear and Controlgear - Part 1: General rules*

IEC 60947-2, *Low-Voltage Switchgear and Controlgear - Part 2: Circuit-breakers*

IEC 60947-4-1, *Low-Voltage Switchgear and Controlgear - Part 4-1: Electromagnetic Contactors and Motor-Starters - Electromechanical Electromagnetic Contactors and Motor-Starters*

IEC 60947-4-2, *Low-Voltage Switchgear and Controlgear - Part 4-2: Electromagnetic Contactors And Motor-Starters - AC Semiconductor Motor Controllers And Starters*

IEC 60947-6-1, *Low-Voltage Switchgear and Controlgear - Part 6-1: Multiple Function Equipment - Automatic Transfer Switching Equipment*

IEC 61000-4-2, *Electromagnetic Compatibility (EMC) – Part 4-2: Testing and Measurement Techniques – Electrostatic Discharge Immunity Test*

IEC 61000-4-3, *Electromagnetic Compatibility (EMC) – Part 4-3: Testing and Measurement Techniques – Radiated, Radio-Frequency, Electromagnetic Field Immunity Test*

IEC 61000-4-4, *Electromagnetic Compatibility (EMC) – Part 4-4: Testing and Measurement Techniques – Electrical Fast Transient/Burst Immunity Test*

IEC 61000-4-5, *Electromagnetic Compatibility (EMC) – Part 4-5: Testing and Measurement Techniques – Surge Immunity Test*

IEC 61000-4-6, *Electromagnetic Compatibility (EMC) – Part 4-6: Testing and Measurement Techniques – Immunity to Conducted Disturbances, Induced by Radio-Frequency Fields*

IEC 61000-4-8, *Electromagnetic Compatibility (EMC) – Part 4-8: Testing and Measurement Techniques – Power Frequency Magnetic Field Immunity Test*

IEC 61000-4-11 (2004), *Electromagnetic Compatibility (EMC) – Part 4-11: Testing and Measurement Techniques – Voltage Dips, Short Interruptions and Voltage Variations Immunity Tests*

IEC 61000-4-13, *Electromagnetic Compatibility (EMC) – Part 4-13: Testing and Measurement Techniques – Harmonics and Interharmonics Including Mains Signalling at A.C. Power Ports, Low-Frequency Immunity Tests*

IEC 62091, *Low-Voltage Switchgear and Controlgear - Controllers for Drivers of Stationary Fire Pumps*

IEEE/ASTM SI 10, *Standard for Use of the International System of Units (SI): The Modern Metric System*

International Special Committee on Radio Interference (CISPR) 61000-6-3, *Electromagnetic Compatibility (EMC) – Part 6: Generic Standards – Section 3: Emission Standard for Residential, Commercial and Light-Industrial Environments*

CISPR 11, *Industrial, Scientific and Medical (ISM) Radio-Frequency Equipment – Electromagnetic Disturbance Characteristics – Limits and Methods of Measurement*

NEMA Standard MG-1, *Motors and Generators*

UL 869A, *Reference Standard for Service Equipment*

UL 891, *Standard for Safety for Switchboards*

## 1.9 Terms and Definitions

For purposes of this standard, the following terms apply:

*Accepted* — This term refers to installations acceptable to the authority enforcing the applicable installation rules. Acceptance is based upon an overall evaluation of the installation. Factors other than the use of certified equipment impact upon the decision to accept, or not to accept. Acceptance is not a characteristic of a product. It is installation specific. A product accepted for one installation may not be acceptable elsewhere.

*Across-the-Line Motor (ATL) Starting* — Full voltage motor starting method. See Direct-on-Line.

*Additive/Foam Pump* — Pump dedicated to deliver a specified rate of foam concentrate to the system proportioner in the water fire extinguishing system of a facility.

*Additive/Foam Pump Controller* — A specially designed electric fire pump controller or diesel engine fire pump controller intended to control the unique requirements of an additive/foam concentrate pump for use in fire suppression.

*Alternate Power Supply* — Alternative term for the Emergency Power Supply for Dual Source combination motor driven fire pump controllers (or fire pump transfer switches). (See Emergency Power Supply).

*Ampacity* — The continuous current-carrying capacity of a conductor or a device.

*Automatic Control* — Control of an operation without human intervention.

*Automatic Transfer Switching Equipment (automatic power transfer switch)* — Self-acting equipment containing the transfer switching device(s) and other necessary devices for monitoring supply circuits and for transferring one or more load circuits from one power supply to another.

*Auxiliary Circuit* — Circuits not essential for the performance of the fire pump controller.

*Battery* — A packaged collection of battery cells. Usually six cells for lead acid batteries.

*Battery Unit* — One or more batteries used to start and run diesel fire pump engines. Two are required.

*Branch Circuit* — The circuit conductors between the final overcurrent device protecting the circuit and the utilization equipment.

*Centrifugal Pump* — A pump in which the pressure is developed principally by the action of centrifugal force.

## Circuit-Breakers

*Circuit-Breaker* — An automatically operated electrical switch designed to protect an electrical circuit from damage caused by overload or short circuit. For the purposes of this standard, the term circuit-breaker (disconnecting means) refers to instantaneous-only circuit-breakers for full service controllers under 600 Volts AC.

*Thermal-magnetic Circuit-Breaker* — A device designed to open and close a circuit by non-automatic means, and to open the circuit automatically on a predetermined overcurrent (overload and short circuit), without damage to itself when properly applied within its rating. These devices are not allowed in Certified fire pump controllers.

*Instantaneous-only Circuit-Breaker* — One intended to provide short circuit protection only.

*Control Circuit* — A circuit that carries the electric signals directing the performance of a fire pump controller, but which does not carry the main power circuit. A control circuit is generally limited to 15A.

*Control Power Transformer (CPT)* — A step down transformer, single or multi-phase, to supply power to controller circuitry at less than line voltage. Also referred to as “controller transformer” and/or “rectifier transformer”. Two or more transformers may be used in cascade, especially in high (medium) voltage controllers.

*Controller* — Device or equipment that serves to control, in some predetermined manner, the electric power delivered to the apparatus to which it is connected. Usually comprised of a cabinet, motor starter, circuit breaker and isolating switch, and other control devices for control of electric motor or diesel engine driven pumps.

*Controller – Limited Service* — Controllers for use with 30 hp (20 kW) or less rated electric motors for driving limited service pumps. These may be for single phase or for three phase limited service motors. This device is limited in application where acceptable to the authority having jurisdiction (AHJ). It does not have a manually operated isolation switch. It uses an inverse time nonadjustable circuit breaker, and has limited locked rotor overcurrent protection. See Fire Pump Controllers. Limited Service Controllers are not certified by the certification agency.

*Controller - With Automatic Power Transfer Switch* — Electric fire pump controller with integral automatic transfer switch for normal power supply and alternate power supply to the controller where required by the authority having jurisdiction (AHJ), or where the normal power supply is unreliable.

*Current Limiters* — Melting link-type devices that, when used as an integral part of a circuit breaker, limit the current during a short circuit to less than the interrupting capacity of the circuit breaker.

*Demand, Pump Demand* — A requirement for fire water. Also called “call to start”.

*Diesel Engine* — An internal combustion engine in which the fuel is ignited entirely by the heat resulting from the compression of the air supplied for combustion. The oil-diesel engine, which operates on fuel injected after compression is practically completed, is the type usually used as a fire pump driver.

*Diesel Engine Fire Pump Controller* — Controller intended to control a diesel engine-driven fire pump.

*Diesel Engine Additive/Foam Pump Controller* — Controller intended to control a diesel engine-driven additive/foam concentrate pump.

*Direct-on-Line Motor (DOL) Starting* — Full voltage motor starting method. See Across-the-Line.

*Disconnecting Means* — A device, group of devices, or other means (i.e., the circuit-breaker in the fire pump controller) by which the conductors of a circuit can be disconnected from their source of supply while under load.

*Disconnecter (Isolating Switch)* — Mechanical switching device which provides, in the open position, an isolating distance in accordance with specified requirements.

**Note:** A disconnector is capable of opening and closing a circuit when either negligible current is broken or made, or when no significant change in the voltage across the terminals of each of the poles of the disconnector occurs. It is also capable of carrying currents under normal circuit conditions and carrying for a specified time currents under abnormal conditions such as those of short circuit.

*Driver* — Electric motor or diesel engine that drives the fire pump.

*Drop-Out Relay* — A relay that, when de-energized, initiates the control function.

*Dual Source Fire Pump Controller* — Controllers for motor driven fire pumps which accept two sources of A.C. (Mains) power.

*Electric Fire Pump Controller* — Controller intended to control an electric motor-driven fire pump.

*Electric Additive/Foam Pump Controller* — Controller intended to control an electric motor-driven additive/foam concentrate pump

*Electromagnetic Compatibility - EMC* — Ability of an equipment or system to function satisfactorily in its electromagnetic environment without introducing intolerable electromagnetic disturbances to anything in that environment.

*Electronic (EMC or ECU) Controlled Engine* — Engines which incorporate Electronic Control Modules (Units) for control of fuel and fuel injection. This is as opposed to “mechanical fuel injection”. Control modules may also control engine speed in lieu of a separate speed governor.

*Electromagnetic Contactor* — Electromagnetic contactor in which the force for closing the normally open main contacts or opening the electromagnetic normally closed main contacts is provided by an electromagnet.

*Electromagnetic Disturbance* — Any electromagnetic phenomenon which may degrade the performance of a device, equipment or system, or adversely affect living or inert matter.

**Note:** An electromagnetic disturbance may be an electromagnetic noise, an unwanted signal or a change in the propagation medium itself.

*Electromagnetic Environment* — Totality of electromagnetic phenomena existing at a given location.

**Note:** In general, the electromagnetic environment is time dependent and its description may need a statistical approach.

*Emergency Power Supply* — The Emergency Power Supply for Dual Source combination motor driven fire pump controllers (or fire pump transfer switches). Also known as Alternate, Stand-by or Back-up Supply.

*Emission (electromagnetic)* — Phenomenon by which electromagnetic energy emanates from a source

*Enclosure* — A surrounding case constructed to provide a degree of protection against incidental contact with the enclosed equipment, and to provide a degree of protection against specified environmental conditions.

*Externally Operable* — Capable of being operated without the need to remove covers or open an enclosure, and without exposing the operator to contact with live parts.

*Feeder* — All circuit conductors between the service equipment or the source of a separately derived electrical system and the final branch-circuit overcurrent device.

*Fire Pump* — Pump dedicated to deliver a specified rate of water flow at a specified pressure to the fire extinguishing system of a premises.

*Fire Pump Controller (FPC)* — Also referred to as “Full Service” fire pump controller. For the purpose of this examination standard, an enclosed group of electrical and mechanical devices that serve to govern, in some predetermined manner, the starting and stopping of the fire pump driver (electric motor or diesel engine) as well as monitoring and signaling the status and condition of the fire pump unit. Typically comprised of a steel cabinet, motor starter, circuit breaker, isolating switch, and other control devices. Controllers for electric motor driven fire pumps are designed for three phase NEMA Design “B” motors or equivalent. Controllers for diesel engine driven fire pumps are used with Certified diesel engine drivers per FM 1333.

*Fire Pump Controller Test Protocol* — Procedure for exercising fire pump controllers to verify their compliance with the requirements of this standard.

*Fire Pump Unit* — An assembled unit consisting of a fire pump, driver, controller, and accessories.

*Full Voltage or Reduced Voltage Starting* — Electric motor controllers may be configured for direct on-line starting (full voltage) or for starting with reduced motor starting current (reduced voltage).

*High Voltage Fire Pump Controller* — Full Service Fire Pump Controllers for high voltage fire pump motors rated in excess of 600 volts. See Medium Voltage Fire Pump Controllers.

*Electromagnetic Immunity* — The ability of a device, equipment or system to perform without degradation in the presence of an electromagnetic disturbance.

*Induction Motor* — Induction motors are probably the simplest and most rugged of all electric motors. They consist of two basic electrical assemblies: the wound stator and the rotor assembly. The rotor consists of laminated, cylindrical iron cores with slots for receiving the conductors. On early motors, the conductors were copper bars with ends welded to copper rings known as end rings. Viewed from the end, the rotor assembly resembles a squirrel cage; hence the name squirrel-cage motor is used to refer to induction motors. In modern induction motors, the most common type of rotor has cast-aluminum conductors and short-circuiting end rings. The rotor turns when the moving magnetic field induces a current in the shorted conductors. The speed at which the magnetic field rotates is the synchronous speed of the motor and is determined by the number of poles in the stator and the frequency of the power supply.

*Inverter Duty Motor* — An A.C. polyphase induction motor that is specifically designed for use with variable frequency drives (i.e. to run at varying speeds within a speed range). This motor has windings that can withstand harmonics and higher voltages, and is also designed with proper cooling to run at lower speeds, and thermally stronger wire insulation. This motor is designed to meet the requirements of NEMA MG-1, Section IV, Part 31, “Definite-Purpose Inverter-Fed Polyphase Motors.”

*Isolating Switch* — A switch intended for isolating an electric circuit from its source of power. It has no interrupting rating and is intended to be operated only after the circuit has been opened by some other means.

*Jockey Pump* — Also known as a pressure maintenance pump, a jockey pump is a low flow pump installed on a fire protection system with the main fire pump in order to keep the system pressurized by making up for small losses in water pressure due to minor leaks and temperature changes without causing the main fire pump to turn on. A jockey pump is designed and installed so that it starts before the main fire pump and returns the system to its minimum static pressure.

*Lockout Feature* — Externally accessible means to preclude an automatic controller from responding to a start signal.

*Manual Power Transfer Switch* — Switch, operated by direct manpower, for transferring one or more load conductor connections from one power source to another. These are not used and not allowed in fire pump systems. See Transfer Switch (Automatic).

*Medium Voltage Fire Pump Controller* — Alternate designation for High Voltage Fire Pump Controllers. See High Voltage Fire Pump Controllers.

*Motor Full Load Current (FLC) or Motor Full Load Amperes (FLA)* — The current(s) drawn by the motor when delivering 100 percent of its rated power output horsepower or kilowatt. See Service Factor.

*Motor Locked Rotor Current (LRC) or Motor Locked Rotor Amperes (LRA)* — The current(s) drawn by the motor when full voltage is applied; but the rotor is at a standstill. Also called stalled rotor current.

*Motor-Rated Output Power* — A measure of power output of the motor when it is operating at its rated full load.

*Non-Automatic Control* — Control of an operation (i.e. starting or stopping of the pump driver) by human intervention using manual electrical or manual mechanical means.

*Non-Pressure Actuated* — Starting of the driver is initiated by means other than by detecting a reduction in water pressure in the sprinkler system piping, such as from a deluge valve, flow switch, temperature sensor or other fire detection equipment.

*Overcurrent* — Current exceeding the rated current.

**Note:** For the purpose of this standard, overcurrent protection includes motor locked-rotor and short circuit protection only.

*Overcurrent Protection (OCP)* — A means (fuses, circuit breaker or other suitable device) to limit current in a circuit. These means may include short circuit and/or overload currents and/or intermediate current protection.

*Pressure Activated* — Starting of the pump driver is initiated by detecting a reduction in water pressure in the sprinkler system piping.

*Pressure Limiting Driver (PLD)* — A variable speed diesel engine for regulating pump discharge pressure.

*Pumping Unit* — Pump, driver and controller, transfer switch equipment, and all necessary accessories; (gauges, pressure recorder, water relief valves, flowmeter, etc.).

*Rated motor speed* — The speed at which the motor shaft turns under full load and is measured in revolutions per minute (rpm).

*Reduced Inrush Line Motor Starting* — Motor starting method whereby the voltage or the current to the motor are restricted for a period of time. Also known as “Reduced Voltage” or “Reduced Current” starting.

*Residential Fire Pump Controller* — Controller intended to control an electric motor-driven residential fire pump.

**Note:** Residential fire pumps are fire pumps intended for use primarily in domestic residences. They are typically limited to one- and two-family units, and are generally single-phase devices. These devices are not part of this standard, and are not acceptable to the certification agency.

*Service Box (For Canada)* — An certified assembly consisting of a metal box or cabinet constructed so that it may be effectually locked or sealed, containing either service fuses and a service switch or a circuit breaker, and of such design that either the switch or circuit breaker may be manually operated when the box is closed.

*Service Entrance Equipment* — Equipment examined and acceptable and suitable for connecting directly to a utility source of power without intervening disconnect means or overcurrent protection.

**Note:** In Canada, a separate “Service Box” is required ahead of a controller.

*Service Equipment* — The necessary equipment, usually consisting of a circuit-breaker or switch and fuses and their accessories, located near the point of entrance of supply conductors to a building or other structure, or an otherwise defined area, and intended to constitute the main control and means to cut-off the supply.

*Service Factor* — The service factor of an A.C. motor is a multiplier that, when applied to the rated horsepower, indicates a permissible horsepower loading that can be carried at the rated voltage, frequency, and temperature. The multiplier 1.15 indicates that the motor is permitted to be overloaded 1.15 times the rated horsepower without insulation breakdown or otherwise significantly reducing service life. (ANSI/NFPA 20 Stipulates limits on motor current and service factor ratings. NEMA MG-1 stipulates conditions for motor service factor operation and derating requirements.) See Motor Full Load Current.

*Short Circuit Protective Device* — A device intended to protect a circuit or parts of a circuit against short circuit currents by interrupting them.

*Short Circuit Rating* — The amount of current a controller can withstand and interrupt as established by testing. Also informally called WIC (Withstand Interrupt Current) rating.

*Single Source Fire Pump Controller* — Controllers for motor driven fire pumps which accept only one source of A.C. (Mains) power. See Dual Source Fire Pump Controllers.

*Squirrel Cage Induction Motor* — A type of three phase alternating current (AC) motor whose rotor is constructed by connecting metal bars together at each end by shorting rings forming a cage-like shape. It is the most common A.C. motor type, commonly referred to “squirrel cage” or simply “induction” motor. See “Induction Motor”.

*System Proportioner* — A device or coordinated group of devices which introduces additive/foam concentrate in a prescribed proportion into the fire water stream.

*Transfer Switch (Automatic)* — A switch that is self-acting for transferring the load from one power source to another. Also referred to as Power Transfer Switch. Fire pump transfer switches must also be operable as manual transfer switches.

*Type-Tested Device* — A device conforming to an established type, comprised of elements (components, devices, equipment) combined and rated as a unit, replicating the constructional and performance features of the typical device which has been verified previously to be in accordance with a designated standard.

*Variable Frequency Drive (VFD)* — A power conversion device which supplies power to a motor at frequencies which vary from the supplied line (mains) power for the purpose of speed control. The term VFD refers to the motor drive unit itself. The term VSD, Variable Speed Drive, refers to the fire pump controller components and variable speed path items.

*Variable Speed Drive (VSD)* — The components that provide the interface between the electric fire pump controller, the Variable Frequency Drive and the electric inverter duty motor.



*Variable Speed Electric Fire Pump Controller (VSEFPC)* — A full service fire pump controller for motor driven fire pumps consisting of a full speed fire pump controller and a variable speed power path capable of running the fire pump motor at either variable speed or at full speed line frequency.

*Wound Rotor Induction Motor* — A three phase motor containing a rotor with windings and slip rings. This motor type permits control of rotor current by connecting external resistance in series with the rotor windings to allow control of motor output torque for acceleration control (reducing inrush starting) or for pump speed control.

## 2 GENERAL INFORMATION

### 2.1 Product Information

- 2.1.1 Fire pump controllers are intended to control drivers of pumps for fire protection. They are a critical component of a fire protection water source. They shall control and monitor the pump driver under all conditions. They shall provide a high degree of reliability to start the pump driver automatically upon sensing loss of fire protection system pressure or by other automatic fire detection equipment. The controller, circuit conductors, and driver are considered to be sacrificial (temporary and permanent damage levels are permitted) in any attempt to start or continue the operation of a distressed pump.
- 2.1.2 When called upon to function by automatic signal, manual-electric signal or manual-emergency actuation, the controller is expected to start the pump driver (electric motor or diesel engine) because “the building is on fire”. Failure to carry out its mission will increase fire damage to the building and its contents; as well as increase business interruption. Certain aspects of these controllers and fire pump installations are considered “sacrificial” in that, overcurrent and other safety aspects of this equipment is relaxed from other typical motor or engine equipment, controllers and installations. This is to allow the equipment to “run to destruction” under certain conditions to assure continuity of the water supply for the maximum amount of time. Other conditions which would result in “imminent (immediate) destruction” are meant to be protected for both safety reasons and to allow “manual intervention” to return the equipment to service, even if impaired. This equipment, then, requires extra caution and uncommon maintenance and care.
- 2.1.3 Fire pump controllers are designed to default to a RUN state or provide an audible alarm and visual indication in the event of a component or system malfunction. They are intended to be located in compliance with local requirements which generally will place them in pump rooms or pump houses that have some specified degree of fire protection. These locations often have sweating overhead pipes, are possibly sprinklered and are in the vicinity of vaults housing other building distribution equipment.
- 2.1.4 Fire pumps are intended to boost water pressure. Many sprinkler systems are assumed to have small leaks for which “Jockey Pumps” (also known as make-up pumps) are installed to maintain desired pressure in the sprinkler pipes, thus preventing the main fire pump from excessive starts and stops. Experience has shown that leakage water flowing through the fire pump (at rest) over long periods of pump inactivity can carry sand, aggregates, rocks, rust and such which collect in the fire pump. These contaminants may prevent normal starting until the pump impeller accelerates to clear the pump housing. This standard recognizes the condition of under-exercised fire pumps by permitting up to 20 seconds at locked rotor current whether the starts are “cold starts” (initial starts) or “hot starts” (restarts). Starting a distressed pump may cause temporary or permanent damage to electrical conductors, equipment and the motor, but this is preferable because pump shutdown for equipment protection could possibly permit its destruction by fire along with the building and its contents.
- 2.1.5 Several examples of the unique construction and installation applications between a fire pump controller and other controllers include the following:
1. All fire pump controllers:
    - a. The main circuit conductors and components are considered to be sacrificial (i.e. temporary and permanent damage levels are permitted) during any attempt to start a distressed motor/pump and to keep it operating.
    - b. They shall provide a high degree of reliability to start the pump driver automatically and suppress a fire upon sensing a pressure drop in the sprinkler pipe or by other automatic fire detection equipment.
    - c. Failures in external control circuits shall not prevent operations of pumps from all other internal or other external means.

- d. External control circuits shall be arranged so that failure of any external circuit (open or short circuit) will not prevent operation of pump(s) from all other internal or external means. Breakage, disconnecting, shorting of the wires or loss of power to these circuits can cause continuous running of the fire pump but shall not prevent the controller(s) from starting the fire pump(s) due to causes other than these external circuits.
  - e. External automatic starting means shall be accomplished by opening a normally closed contact on the external means to de-energize a normally energized control circuit in the controller.
  - f. While external start buttons or other starting means are permitted, the controller shall not be equipped with any means to accommodate remote stopping (a remote STOP button shall not be used) and no terminals shall be provided inside the controller to allow an external remote stopping device.
  - g. Nuisance starts are permitted in the case where a failure of internal control components might cause the motor to start running.
  - h. Shall provide manual means to exercise the motor or engine on a weekly basis, and a means to disable any automatic methods used to exercise the motor or engine on a weekly basis.
2. Electric motor fire pump controllers
    - a. They shall include means for external, manual mechanical operation of the controller in the event of loss of ability to close the electromagnetic contactor electrically/magnetically.
    - b. Thermally reactive overcurrent protective devices are not permitted. The controller provides short circuit and locked rotor protection only. Any other overload protection is not allowed.
    - c. Releases of the FPC-overcurrent protective devices (short circuit protective and locked rotor protective devices) shall permit it to carry 300 percent of rated operational motor current for an indefinite period of time, or until a fault (short circuit) condition occurs.
  3. Diesel engine fire pump controllers
    - a. When an automatic or manual signal to start/run exists, (except under TEST) the controller shall not shutdown the engine for any reason except OVERSPEED. When in TEST mode, the controller may shutdown under low oil pressure and high engine temperature conditions. If a Failure to Start alarm exists after the completion of the engine cranking cycle due to the controller receiving no signal from the engine speed sensor that the engine is operating the controller shall leave the fuel and water solenoids open for a minimum duration of 60 minutes unless one of the two following items is provided:
      1. There is supervision on the speed sensor itself to confirm that it has not lost power or become disconnected from the engine;
      2. There is a secondary speed switch or secondary sensor to monitor engine status, or the signal from the water pressure sensor indicates no demand to start; then the controller can secure power to the fuel and water solenoids, initiate audible alarm, and await manual intervention. These conditions mentioned illustrate the sacrificial nature while fighting a fire.
    - b. Diesel engine fire pump controllers shall be provided with two independent battery chargers capable of fully recharging both battery units within 24 hours.
- 2.1.6 An installation with two fire pumps will increase the reliability and safety of the installation especially if the two fire pumps are supplied from two different power supplies, or by different driver types (a diesel engine drive and an electric motor drive). This is especially true during maintenance or repairing of a single controller, as fire protection is still being maintained by the other fire pump.
  - 2.1.7 In order to meet the intent of this standard, controllers must be examined on a model-by-model, type-by-type, manufacturer-by-manufacturer, and plant-by-plant basis. This is predicated on the basis that identical designs, fabricated in identical materials by different manufacturers or, even by different plants of the same manufacturer, have been seen to perform differently in testing. Sample controllers, selected in conformance to this criterion, shall satisfy all of the requirements of this standard.

## 2.2 Certification Application Requirements

- 2.2.1 The manufacturer shall provide, at a minimum, the following preliminary information with any request for certification consideration:
- a. A complete list of all models, types, ratings, and options for the products being submitted for certification consideration;
  - b. A complete description of the product construction, specifically enclosure type and environmental rating, and other critical construction features identified in this standard;
  - c. Product assembly drawings as follows:
    1. General schematic of the enclosure showing dimensions and electrical service data;
    2. Electrical system schematic diagram of controller;
    3. Field connections diagram;
    4. Drawing of the pressure sensing device;
    5. Logic diagram for microprocessor;
    6. Document identifying all the product options;
    7. List of components/parts for each controller;
    8. Required markings and labels; and,
    9. Pressure switch to include Pressure Transducer/Transmitter
  - d. Copy of the installation/operation manual
  - e. Copy of the sales literature/brochures for each controller type
  - f. The number and location of manufacturing facilities.
- 2.2.2 All documents shall be controlled by the manufacturer's Quality Assurance procedures and shall identify the manufacturer's name, document number or other form of reference, title, date of last revision, and revision level. All foreign language documents shall be provided with English translation.
- 2.2.3 Based upon the complexity of the examination, the following documents may also need to be submitted:
- 2.2.3.1 Electric Motor Fire Pump Controllers - Additional Documents
- a. Power Component Tabulation: - A tabulation shall be supplied as a control drawing including the following controller information (as applicable): horsepower; voltage; full load amps (FLA); part number and rating of the following components; isolation switch, circuit breaker, contactor(s), autotransformer, resistors (primary and transition), transfer switches and power wiring.
  - b. Isolation Switch: Manufacturer, manufacturer's part number, type of device (i.e. molded case switch), and all electrical ratings.
  - c. Motor Control Contactor: Manufacturer, manufacturer's part number, NEMA size (if applicable), and all electrical ratings.
  - d. Motor Circuit Breaker: Manufacturer, manufacturer's part number, type of protection characteristics, and all electrical ratings.
  - e. Starting Resistors: Manufacturer, manufacturer's part number, NEMA ICS-2 Class Number, and all electrical ratings.
  - f. Transfer Switch: Manufacturer, manufacturer's part number, and all electrical ratings.
  - g. Autotransformer/Control Transformer: Manufacturer, manufacturer's part number, and all electrical ratings.
  - h. Reactors: Manufacturer, manufacturer's part number, and all electrical ratings.

- i. Motor Circuit Wiring: Cross-sectional area of wire in American Wire Gauge (AWG) or circular mils (CM), conductor material, wire type designation, insulation temperature rating, and voltage rating.
- j. Components such as relays, timers, etc.: Manufacturer, manufacturer's part number, and all electrical ratings.
- k. Soft Starters: Type and electrical schematic
- l. Variable Frequency Drives and Related Components: Line Reactors, VFD Circuit Protection Coordination, cooling provisions and calculations and other parameters affecting performance, reliability and/or service life.

#### 2.2.3.2 Diesel Engine Fire Pump Controllers - Additional Documents

- a. Control Transformer: Specification showing the manufacturer's name, manufacturer's part number, frequency, primary voltage, VA, and secondary voltage(s).
- b. Overload Protection: Such as fuse or circuit breaker if used to protect the control circuitry, provide information on manufacturer, manufacturer's part number, type and all electrical ratings.
- c. Battery Charger: Provide all details related to this device: electrical schematic(s); final assembly drawings and parts lists sufficient to detail circuit components (all), and their locations; parts/components list; enclosure/chassis drawings showing all construction details, sheet metal gauge and paint finish.

### 2.3 Requirements for Samples for Examination

- 2.3.1 Following set-up and authorization of a certification examination, the manufacturer shall submit samples for examination and testing. Sample requirements are to be determined by the certification agency following review of the preliminary information. Sample requirements may vary depending on design features, results of prior testing, and results of the foregoing tests. It is the manufacturer's responsibility to submit samples representative of production. Tests shall be made to prove compliance with the requirements of this standard. Tests shall be carried out by the manufacturer at his facility, an certified laboratory or at a recognized laboratory at the discretion of the certification agency's Engineer. Where appropriate, and at the discretion of the certification agency, special tests may also be performed.
- 2.3.2 Prior to any testing, the fire pump controller shall be examined to conform to the manufacturer's drawings and specifications, and to the certification agency's requirements. It shall be first verified that the sample conforms to the physical and structural requirements described in Section 3, General Requirements. certification testing shall then only be carried out on a fully assembled, completely labeled, production quality fire pump controller. Prototype or partially assembled fire pump controllers and subsystems are not acceptable, other than for specific type testing (i.e. short circuit testing, battery charger testing, pressure switch/transducer testing). Testing equipment, configurations and calibration must meet the requirements of this standard and the the certification agency's engineer.

### 3 GENERAL REQUIREMENTS

#### 3.1 Review of Documentation

- 3.1.1 During the initial investigation and prior to physical testing, the manufacturer's specifications, technical data sheets, and design details shall be reviewed to assess the ease and practicality of installation and use. The product shall be capable of being used within the limits of the certification investigation.
- 3.1.2 The manufacturer's electrical specifications and design drawings shall fully describe the product. All critical markings shall be indicated and terminal block numbers for field connections clearly shown.
- 3.1.3 All documents pertaining to the product materials, dimensions, processing, and marking shall be controlled by the manufacturer's quality assurance procedures, and shall identify the manufacturer's name, document number or other form of reference, title, date of last revision, and revision level. All foreign language drawings shall be provided with an English translation.

#### 3.2 Design and Functional Features

- 3.2.1 Electric fire pump controller/automatic electric fire pump controller
- 3.2.1.1 Controllers rated 600 Volts or less, and shall be in a fully functional "ready to start" state within 10 seconds upon application of A.C. power.
- 3.2.1.2 Pressure activated  
Starting of the motor is initiated by detecting a reduction in water pressure.
- 3.2.1.3 Non-pressure actuated  
Starting of the motor is initiated by means other than by detecting a reduction in water pressure, such as deluge valve tripping, flow switch or fire detection equipment.
- 3.2.1.4 Non-automatic electric fire pump controller  
Starting of the motor is initiated by manual electrical means (i.e. push button) or manual mechanical means (i.e. emergency-run mechanical control).
- 3.2.1.5 Electric fire pump controller with or without power transfer switch  
Controllers may be provided for one or two sources of electrical power.
- 3.2.1.6 Full voltage or reduced voltage starting  
Controllers may be provided for direct on-line starting (full voltage) or for starting with reduced motor inrush current (reduced voltage).
- 3.2.1.7 Electric fire pump controller basic functions  
An electric fire pump controller shall perform the following basic functions:
- Connects (or transfers) the electric motor to the appropriate power supply (primary, alternative, second utility);
  - Starts, controls and stops the operations of the electric drive motor;
  - Provides overcurrent protection against locked rotor currents and short circuit currents;
  - Monitors and supervises the operation of the system, and provides appropriate signals and alarms;
  - To have a general arrangement in compliance with Figure B-1, Figure B-2, Figure

- B-3, Figure B-4 or Figure B-5;
- f. Means to conduct a periodic weekly test of the system.
- g. Metering: means to measure voltage and currents without opening the controller;
- h. Means to alarm if and when the motor is running under single phase conditions (motor single phasing).

#### 3.2.1.8 Electric fire pump controller standard equipment

The electric fire pump controller shall comprise the following equipment:

- a. Enclosure;
- b. Critical components;
  - 1. Actuators;
  - 2. Disconnecting device;
  - 3. FPC-overcurrent protective devices (SCPD and LRPD);
  - 4. Full voltage starting means;
  - 5. Reduced voltage starting means;
  - 6. External means of measuring voltage and current;
  - 7. Power transfer switch; where required,
  - 8. VFD and related components, when required.

#### 3.2.1.9 All components shall comply with their own relevant NEC or IEC product standard, where applicable, and the additional requirements of this standard.

- a. Voltage surge arrester, (Not required if the controller can withstand without damage a 10 kV impulse in accordance with ANSI/IEEE C62.41, or the controller is rated in excess of 600 Volts);
- b. Pressure recorder, (When appropriate to the installation or as required by the authority having jurisdiction);
- c. Sensors, detectors, monitoring devices, alarms and appropriate signal devices.
- d. Control Power Transformers;
 

**Note:** fusing is not allowed for circuitry involved with pump operation. [Exception being High (Medium) Voltage Controllers]
- e. Door Interlocking to prevent powering up the unit with any of its doors open, and to prevent opening any of its doors while the controller is powering up. This involves either the isolating switch, or the circuit breaker with controllers rated 600 Volts or less, or the Isolating Switch in High/Medium Voltage Controllers.

#### 3.2.1.10 The controller may include other optional equipment that is the subject of agreement between the manufacturer and the user. Such equipment must be evaluated under this standard, and must be specifically approved by the AHJ.

### 3.2.2 Limited Service Electric Controller

Limited service controllers are not certified by the certification agency. The following is provided as reference for the reader since these devices exist in the fire protection community.

Limited service electric controllers must meet all the provisions of automatic full service electric fire pump controllers with the following exceptions:

- a. The locked rotor overcurrent protection may be achieved by using an inverse time nonadjustable circuit breaker having a standard rating between 150 percent and 250 percent of the motor full-load current.
- b. The manually operated isolating switch is not required.

Limited service electric controllers are only used for across-the-line starting of squirrel cage induction motors of 30 hp (20 kW) or less, and 600 Volts or less, and where they are acceptable to the authority

having jurisdiction. The limited service controller shall have a short circuit current rating not less than 10,000 Amps. Limited service electric controllers shall not be used with additive/foam pump or additive pump motors in fire extinguishing systems.

### 3.2.3 High Voltage electric fire pump controller

Electric fire pump controllers that are rated in excess of 600 Volts and must meet all the provisions of automatic electric fire pump controllers, except as outlined below.

- 3.2.3.1 Disconnecting of conductors within the controller is allowed when measuring line voltages and currents with test instruments.
- 3.2.3.2 An ammeter shall be provided on the exterior of the controller with a suitable means for reading the current in each phase with an accuracy within  $\pm 5$  percent of motor nameplate current.
- 3.2.3.3 An indicating voltmeter or voltmeters, deriving power of not more than 125 Volts from a transformer or transformers connected to the high voltage supply, shall be provided on the exterior of the controller to read each phase voltage with an accuracy within  $\pm 5$  percent of motor nameplate voltage
- 3.2.3.4 The isolating switch shall be designed to prevent the switch from being opened under electrical load.
- 3.2.3.5 A load-break disconnecting means is permitted to be used in lieu of the isolating switch if the fault closing and interrupting ratings equal or exceed the requirements for disconnect (load break) switches in ANSI/UL 347, *Standard for Safety for High Voltage Industrial Control Equipment* and meet all the requirements of the installation, then the requirement of Section 3.2.3.4 is not required.
- 3.2.3.6 Special precautions shall be taken in locating the pressure-actuated switch to prevent any water leakage from coming in contact with high-voltage components.
- 3.2.3.7 The low-voltage control circuit shall be supplied from the high voltage source through a stepdown transformer or transformers protected by high-voltage fuses in each primary line. The secondary of the line supplied control power transformer(s) shall be grounded unless all external control devices are rated for the line voltage.
- 3.2.3.8 For the low-voltage control circuit, the transformer(s) power supply shall be interrupted when the isolating switch is in the open position.
- 3.2.3.9 For the low-voltage control circuit, the secondary of the transformer and control circuit that are necessary for proper operation of the controller shall not have overcurrent protective devices connected in them, and shall be permitted to be ungrounded.
- 3.2.3.10 For the low-voltage control circuit, one secondary line shall be grounded unless all control and operator devices are rated for use at the high (primary) voltage.
- 3.2.3.11 A visible indicator shall be provided to indicate that power is available. The current supply for the visible indicator shall come from the secondary of the control circuit transformer through resistors or from a small-capacity stepdown transformer that shall reduce the control transformer secondary voltage to that required for the visible indicator. If the visible indicator is an incandescent pilot lamp, it shall be accessible for replacement.
- 3.2.3.12 Necessary provisions shall be made; including such interlocks as might be needed, to protect personnel from accidental contact with high voltage. The high voltage door shall be



interlocked to the isolating switch. The isolating switch shall be interlocked to the motor contactor, unless it is rated as a disconnect switch, to prevent opening or closing it unless the contactor is open.

- 3.2.3.13 A contactor in combination with current-limiting motor circuit fuses, such as “R” rated fuses, shall be permitted to be used in lieu of the circuit breaker as the disconnecting means to protect the motor branch circuit, if all of the following requirements are met:
- a. Current-limiting motor circuit fuses shall be mounted in the enclosure between the isolating switch and the contactor, and shall interrupt the short circuit current available at the controller input terminals.
  - b. Current-limiting motor circuit fuses shall have an adequate interrupting rating to provide the suitability rating (available short circuit current at the line terminals) of the controller.
  - c. The current-limiting fuses shall be sized to hold 600 percent of the full-load current rating of the motor for at least 100 seconds.
  - d. A spare set of fuses of the correct rating shall be kept readily available in a compartment or rack within the controller enclosure. These spare fuses shall be provided and installed by the controller manufacturer prior to shipment, or provided by the controller manufacturer at the time of system start-up and acceptance.
- 3.2.3.14 Tripping of the locked rotor overcurrent device shall be permitted to be accomplished by opening the motor contactor coil circuit or circuits to drop out the contactor.
- 3.2.3.15 Means shall be provided to restore the controller to normal operation by an externally manually reset device.
- 3.2.3.16 The controller shall be equipped with an external emergency run handle or lever that operates to mechanically close the motor-circuit switching mechanism. This handle or lever shall provide for manual (non-automatic) continuous running operation of the motor, independent of any electrical, magnetic and pressure activated control circuits. The handle or lever must be mechanically latched or held for manual operation in the actuated position. This mechanical latching can be automatic or non-automatic, and the lever or handle must be designed to move in one direction only from the off position to the final position. The emergency run handle or lever must be located on the front exterior of the controller enclosure, and easily noticeable.
- 3.2.3.17 When the contactor is latched during emergency-run manual operation, the locked rotor overcurrent protection is not required.
- 3.2.3.18 The controller shall provide means such that both the opening and the closing of the contactor using the emergency-run manual operation shall match or exceed the speed of operation under normal electrical actuation and releasing.

### 3.2.4 Residential fire pump controller (pump driven by an electric motor only)

Residential fire pump controllers are a sub-class of electric fire pump controllers with a restricted scope of applications that have been introduced for residential occupancies only (i.e. NFPA 13D, single/dual family dwellings). Residential fire pump controllers are not certified by the certification agency.

### 3.2.5 Diesel engine fire pump controller

A diesel engine is the pump driver for this class of fire pump controller. The diesel engine controller has a general arrangement in compliance with Figure B-6. Starting of the diesel engine is made by means of a controlled signal to initiate starting using auxiliary power from a 12VDC or 24VDC battery set, and not from the main electrical power circuit.

#### 3.2.5.1 Pressure actuated

Starting of the engine is initiated by detecting a reduction in water pressure.

#### 3.2.5.2 Non-pressure actuated

Starting of the engine is initiated by means other than by detecting a reduction in water pressure, such as deluge valve, flow switch or fire detection equipment and/or remote start manual switch or push button.

#### 3.2.5.3 Diesel engine fire pump controller basic functions

The diesel engine fire pump controller shall provide four basic functions:

- a. Controls electrical means to start and run and stop the engine;
- b. Monitors the engine and other system conditions and performs supervisory functions where appropriate;
- c. Maintains the electric charge on the engine starting batteries;
- d. Initiates a periodic weekly test of the system.

#### 3.2.5.4 Diesel engine fire pump controller standard equipment

The diesel engine fire pump controller shall be equipped with the following standard equipment (the controller may include other optional equipment that is the subject of agreement between the manufacturer and user):

- a. Moisture resistant, lockable enclosure with a breakable glass panel or tamper resistant mechanism (see Section 4.7.2.2) which permits access for emergency manual start;
- b. Manually operated electrical actuators to start the engine;
- c. Visual indicators and audible alarms;
- d. Electrical contacts to initiate remote alarm;
- e. Battery chargers (one for each 12 V or 24 V battery);
- f. Pressure recorders, in pressure actuated controllers;
- g. A means to disable the periodic weekly test timer. Unless otherwise agreed upon by the building owner, the certification agency requires that the 30 minute weekly test of the diesel fire pump system be conducted manually and not by automatic means. As provided, the operation of both manual testing and automatic test timers shall be verified, as well as the means to disable the automatic function.

### 3.2.6 Additive/Foam pump controller (pump driven either by an electric motor or by a diesel engine)

Special electric fire pump controllers or special diesel engine fire pump controllers intended for the unique requirements of additive/foam concentrate pumps.

- 3.2.6.1 This class of controller may be associated with either an electric motor driven system or a diesel engine driven system. All of the relevant requirements for electric motor driven or diesel engine driven systems apply. The unique requirements are dictated by the fact that, unlike water, the additive/foam concentrate is supplied in measured quantities. The result is

a set of special requirements to govern the situation wherein the store of additive/foam concentrate has been depleted during the exercise of suppressing a fire.

- 3.2.6.2 The requirements for additive/foam pump controllers are identical to automatic controllers with the following additions:
- a. Automatic starting shall be accomplished by the opening of a remote contact. A pressure-actuated device described is not required.
  - b. Manual stopping shall be the only method of stopping.
  - c. The controller shall contain a lockout feature. This lockout shall be indicated by a visible indicator and provisions for annunciation at a remote location.

### 3.2.7 Variable Speed Electric Motor Driven Fire Pump Controllers

Controllers equipped with variable speed pressure limiting control are basically an automatic electric fire pump controller with an integrally mounted and wired variable frequency drive that can alter the rotational speed of the electric motor that drives the fire pump (See Figure B-9). Ensure that the electric motor is designed for variable frequency drive duty. These controllers must meet all requirements for automatic electric fire pump controllers and the requirements listed below.

- 3.2.7.1 The variable speed pressure limiting control shall have a horsepower rating at least equal to the motor horsepower or shall have an ampere rating not less than the motor full-load current, whichever is greater.

- 3.2.7.2 Upon failure of the variable speed pressure limiting control to keep the system pressure at or above the set pressure of the variable speed pressure limiting control system, the controller shall bypass and isolate the variable speed pressure limiting control system and operate the pump at rated speed.

**Note:** The bypass mode constitutes all of the characteristics of a non-variable speed fire pump controller.

**Note:** The bypass contactor shall be energized only when there is a pump demand to run and the variable speed pressure limiting control is in the fault condition, or if the mode switch is set to the fixed speed position.

- 3.2.7.3 If the system pressure remains below the set pressure for more than 15 seconds, the bypass operation shall occur.

- 3.2.7.4 If the variable speed drive indicates that it is not operational within 5 seconds, the bypass operation shall occur.

**Note:** Variable speed drive units (VSDs) shall have a positive means of indicating that the drive is operational within a few seconds after power application. If the VSD fails, the transfer to full speed operation shall occur immediately.

- 3.2.7.5 Means shall be provided to prevent higher than normal in-rush currents when transferring the fire pump motor from the variable speed mode to the bypass mode.

**Note:** A motor running at reduced frequency cannot be connected immediately to a source at line frequency without creating high transient currents that can cause tripping of the fire pump circuit breaker. It is also important that the controller provides a means to prevent connection of line frequency power (back feed) to the VSD since this will damage the VSD, and, more importantly, can cause the fire pump circuit breaker to trip which takes the pump out of service.

- 3.2.7.6 Once the variable speed pressure limiting control is bypassed, the unit shall remain bypassed until shutdown.
- 3.2.7.7 The bypass contactors shall be operable using the emergency-run handle or lever that provides for non-automatic continuous running operation of the motor.
- 3.2.7.8 The variable speed drive shall be line and load isolated when not in operation.
- 3.2.7.9 The variable speed drive load isolation contactor and the bypass contactor shall be mechanically and electrically interlocked to prevent simultaneous closure.
- 3.2.7.10 Separate variable speed drive circuit protection shall be provided between the line side isolating contactor for the variable speed drive and the load side of the circuit breaker that is used as the disconnecting means for the motor branch circuit. This circuit protection shall be coordinated to prevent the circuit breaker from tripping due to a fault condition in the variable speed circuitry.
- Note:** The intent is to prevent tripping of the fire pump controller circuit breaker due to a variable speed drive failure and thus maintain the integrity of the bypass circuit.
- 3.2.7.11 Power quality correction equipment shall be located in the variable speed circuit ahead of the VFD with a minimum provision of 5 percent line reactance.
- 3.2.7.12 Power quality coordination is not required where the system voltage does not exceed 480 Volts and cable lengths between the motor and controller do not exceed 100 ft. (30.5 meters). Where higher system voltages or longer cable lengths exist, the cable length and motor requirements shall be coordinated by all concerned parties which includes the installing pump manufacturer, controller manufacturer and end user.
- Note:** As the motor cable length between the controller and motor increases, the VSD high frequency switching voltage transients at the motor will increase. To prevent the transients from exceeding the motor insulation ratings, the motor manufacturer's recommended cable lengths must be followed.
- 3.2.7.13 All control and power devices and components required to keep the controller in automatic operation shall be within lockable cabinets.
- 3.2.7.14 The variable speed pressure sensing element shall be connected between the pump discharge flange and the discharge control valve, as appropriate, with a 1/2 in. (15 mm) nominal size, or larger, inside diameter pressure line. This sensing element shall only be used to control the variable speed drive.
- 3.2.7.15 Common pressure control shall not be used for multiple pump installations. Each controller pressure sensing control circuit shall operate independently.
- 3.2.7.16 Means shall be provided to manually select between variable speed and bypass mode.
- 3.2.7.17 A visible indicator shall be provided to indicate when the variable speed drive has failed.
- 3.2.7.18 A visible indicator shall be provided to indicate when the controller is in bypass mode.
- 3.2.7.19 Visible indication shall be provided on all controllers equipped with variable speed pressure limiting control to actuate at 115 percent of set pressure (over-pressure).
- 3.2.7.20 Controllers shall be equipped with contacts (open or closed) to operate circuits for the conditions of drive failure, bypass mode, and over-pressure as described above.

3.2.7.21 The controller shall be provided with suitable adjusting means to account for various field conditions.

**Note:** This allows for field adjustments to reduce hunting, excessive overshooting, or oscillating.

3.2.7.22 As necessary, the maximum allowed turn-down ratio shall be provided by the controller manufacturer to prevent motor overheating at reduced speed operation.

3.2.7.23 The maximum operating frequency shall not exceed line frequency

3.2.7.24 Means shall be provided and permanently attached to the inside of the controller enclosure to record the following settings:

- a. Variable speed pressure limiting set point setting
- b. Pump start pressure
- c. Pump stop pressure

### 3.2.8 Power Transfer Switch Arrangements

For pump(s) driven by electric motor(s) where reliable power cannot be obtained from one source, or when required by the authority having jurisdiction, electric fire pump controllers are required to have an on-site electrical power transfer device that will automatically select power from one of two sources (normal and alternate supply) to maintain pump readiness and operation. Two acceptable methods are described below as Arrangement I and Arrangement II.

#### 3.2.8.1 Arrangement I, Listed Combination Fire Pump Controller and Power Transfer Switch

3.2.8.1.1 Where the power transfer switch consists of a self-contained power switching assembly, this assembly shall be housed in a barriered compartment of the fire pump controller or in a separate enclosure attached to the controller and marked "Fire Pump Power Transfer Switch".

3.2.8.1.2 The isolating switch located within the power transfer switch enclosure or compartment shall be provided ahead of the alternate input terminals of the transfer switch, and meet the construction requirements in Section 4 of this standard.

3.2.8.1.3 The isolating switch shall be supervised to indicate when it is open. This supervision shall operate an audible and visible signal on the fire pump controller/automatic transfer switch combination, and permit monitoring at a remote point where required by the authority having jurisdiction.

3.2.8.1.4 The isolating switch shall be suitable for the available short circuit of the alternate source as described below:

- a. Where the alternate source is provided by a second utility power source, the transfer switch emergency side shall be provided with an isolation switch and circuit breaker complying with the construction requirements in Section 4 of this standard.
- b. Where the alternate source is supplied by one or more upstream transfer switches that can singly or in combination feed utility or on-site generated power to the fire pump controller, the controller shall be equipped with the alternate side circuit breaker and isolating switch that comply with the construction requirements in Section 4 of this standard.
- c. Where the alternate source is supplied by a generator whose capacity

exceeds 225 percent of the fire pump motor's rated full-load current, the controller shall be equipped with the alternate side circuit breaker and isolating switch that comply with the construction requirements in Section 4 of this standard.

### 3.2.8.2 Arrangement II, Individually Listed Fire Pump Controller and Power Transfer Switch

- 3.2.8.2.1 The stand alone power transfer switch must be located within the pump room for applications of power transfer between the normal supply and one alternate supply. It must be Certified for the service. It shall include marked short circuit ratings for both the normal source circuit and the emergency (alternate) source circuit.
- 3.2.8.2.2 An isolating switch, or service disconnect shall be provided ahead of the normal and alternate input terminals of the transfer switch. The isolating switch shall comply with the requirements in Section 4 of this standard.
- 3.2.8.2.3 Where the alternate source is provided by a second utility power source, the transfer switch emergency side shall be provided with an isolation switch and circuit breaker complying with the construction requirements in Section 4 of this standard. This circuit breaker shall provide overcurrent protection for the transfer switch (see Section 3.2.8.2.5.f.) and shall be selected or set to indefinitely carry the locked rotor current of the fire pump motor.
- 3.2.8.2.4 Where the alternate source is provided by an on-site generator set, the transfer switch emergency side shall be provided with an isolation switch and optional circuit breaker complying with the construction requirements in Section 4 of this standard.
- 3.2.8.2.5 The isolating switch ahead of the alternate source input terminals of the transfer switch shall meet the following requirements:
  - a. The isolation switch shall be lockable in the "ON" position (closed position).
  - b. A placard shall be externally installed on the isolating switch stating "Fire Pump Isolating Switch" with letters at least 1 in. (25 mm) in height.
  - c. A placard shall be placed adjacent to the fire pump controller stating the location of the isolating switch and the location of the key (if the isolating switch is locked).
  - d. The isolating switch shall be supervised with an audible and visible signal on the transfer switch enclosure and permit monitoring at a remote point where required, to indicate when it is not closed, by one of the following methods:
    - 1. Central station, proprietary, or remote station signal service
    - 2. Local signaling service that will cause the sounding of an audible signal at a constantly attended point.
    - 3. Locking the isolating switch closed
    - 4. Sealing of isolating switches and weekly recorded inspections where isolating switches are located within fenced enclosures or in buildings under the control of the owner
  - e. Each fire pump controller requires a dedicated transfer switch. Each transfer switch shall supply only one fire pump controller.
  - f. The overcurrent protection of Section 3.2.8.2.3 shall be coordinated with the short circuit rating restrictions of the transfer switch. When required,

the size (ampere rating) of the transfer switch shall be increased (up-sized) to achieve said coordination.

**Note:** Manufacturers of transfer switches shall publish charts or tables that restricts the maximum size (ampere rating) of the overcurrent protection for various devices (fuses and breakers) and which still maintain the required short circuit ratings.

- g. The transfer switch shall be so equipped so as to meet all of the requirements of Section 3.2.8.3, including phase reversal circuitry, isolating switch supervision, labeling provisions, lockout circuitry, motor inrush current protection and alarm circuitry.
- h. The transfer switch enclosure, and the enclosure for any related equipment, shall be no less than NEMA Type 2 or IEC Code IP31.
- i. Any external components, devices, equipment or circuitry must be Certified for fire pump service and be specifically accepted by the AHJ.

### 3.2.8.3 Automatic Power Transfer Switch Requirements for Arrangement I and Arrangement II Configurations

- 3.2.8.3.1 Manual transfer switches shall not be used to transfer power between the normal supply and the alternate supply of power to the fire pump controller.
- 3.2.8.3.2 No remote device(s) shall be installed that will prevent automatic operation of the transfer switch.
- 3.2.8.3.3 Each fire pump shall have its own dedicated power transfer switch, when an emergency/alternate power source is required.
- 3.2.8.3.4 The power transfer switch shall be specifically listed for fire pump service, and meet the requirements of Section 5.14, Locked Rotor Overcurrent Protection Test.
- 3.2.8.3.5 The power transfer switch shall be suitable for the available short circuit currents at the transfer switch normal and alternate input terminals.
- 3.2.8.3.6 The power transfer switch shall be electrically operated and mechanically held.
- 3.2.8.3.7 The power transfer switch shall have an ampere rating not less than 115 percent of the motor full-load current and also capable of switching the motor locked rotor current.
- 3.2.8.3.8 A means for safe manual (non-electrical) operation of the power transfer switch shall be provided. This manual means is not required to be externally operable.
- 3.2.8.3.9 The following applies when the power transfer switch is electrically downstream of the fire pump controller circuit breaker:
  - a. Turning off the normal source isolating switch or the normal source circuit breaker will not inhibit the transfer switch from operating.
  - b. The power transfer switch shall be provided with undervoltage-sensing devices to monitor all ungrounded lines of the normal power source.
  - c. Where the voltage on any phase at the load terminals of the circuit breaker within the fire pump controller falls below 85 percent of motor-rated voltage, the power transfer switch shall automatically initiate starting of the standby generator, if provided and not running, and initiate transfer to the alternate source.

- d. Where the voltage on all phases of the normal source returns to within acceptable limits, the fire pump controller shall be permitted to be retransferred to the normal source.
  - e. Phase reversal of the normal source power (connected to line terminals of the motor contactor) shall cause a simulated normal source power failure upon sensing phase reversal, and shall be indicated by a visible indicator.
- 3.2.8.3.10 Where the power transfer switch is electrically upstream of the fire pump controller circuit breaker, the voltage can be sensed at the input to the power transfer switch instead of at the load terminals of the fire pump circuit breaker.
- 3.2.8.3.11 Voltage and frequency sensing devices shall be provided to monitor at least one ungrounded conductor of the alternate power source, except where the alternate source is provided by a second utility power source, then the undervoltage sensing devices shall monitor all ungrounded conductors instead of a frequency sensing device.
- 3.2.8.3.12 Transfer to the alternate source shall be inhibited until there is adequate voltage and frequency to serve the fire pump load, except where the alternate source is provided by a second utility power source.
- 3.2.8.3.13 Two visible indicators shall be provided to externally indicate the power source to which the fire pump controller is connected.
- 3.2.8.3.14 Means shall be provided to delay retransfer from the alternate power source to the normal source until the normal source is stabilized. This time delay shall be automatically bypassed if the alternate source fails.
- 3.2.8.3.15 Means shall be provided to prevent higher than normal in-rush currents when transferring the fire pump motor from one source to the other.
- 3.2.8.3.16 The power transfer switch shall not have integral short circuit or overcurrent protection.
- 3.2.8.3.17 When the alternate power source is an on-site generator set, the power transfer switch shall have a device to delay starting of the alternate source generator to prevent nuisance starting in the event of momentary dips and interruptions of the normal source.
- 3.2.8.3.18 When the alternate power source is an on-site generator set, the power transfer switch shall be tied into a circuit loop to the alternate source generator whereby either the opening or closing of the circuit will start the alternate source generator, when commanded by the power transfer switch.
- 3.2.8.3.19 When the alternate power source is an on-site generator set, and the alternate isolating switch or the alternate circuit breaker (circuit breaker is optional for Arrangement II configuration) is in the open or tripped position, there shall be a means to prevent the power transfer switch from sending the signal for starting the alternate source generator. Also, the alternate isolating switch and the alternate circuit breaker shall be monitored to indicate when one of them is in the open or tripped position, except when the alternate isolation switch and the alternate circuit breaker are both installed and interlocked.
- 3.2.8.3.20 A momentary test switch, externally operable, shall be provided on the enclosure that will simulate a normal power source failure.



3.2.8.3.21 Auxiliary open or closed contacts mechanically operated by the fire pump power transfer switch mechanism shall be provided for remote indication where two sources of power are required due to the normal source being unreliable. This signal shall indicate whenever the transfer switch is in the alternate source position. This signal circuit shall be energized by a separate, reliable, supervised power source. The resultant power provided to energize the signal circuit shall be a maximum of 125 Volts AC.

### 3.2.9 Electrical Characteristics

#### 3.2.9.1 Rated operational voltage ( $U_e$ )

The rated operational voltage for a fire pump controller is a value of voltage which, combined with a rated operational current, determines the application of the equipment and to which relevant tests are referred.

#### 3.2.9.2 Rated operational current ( $I_e$ ) or rated operational power

The rated operational current for an electric fire pump controller is a value of current which is dictated by the rated operational current of the electric motor which drives the fire pump. The rated operational A.C. input current for a diesel engine fire pump controller is a value of current which is dictated by the maximum load current of the battery charger(s) supply within the controller. The rated D.C. voltage of a diesel engine fire pump controller is the nominal voltage of the battery units. The D.C. current drawn by the controller is its standby current draw or the engine running current draw. These are measured under single battery conditions and with the battery charger A.C. power supply (mains) disconnected and with the engine alternator disconnected. The D.C. output current rating for engine terminals and alarm contact ratings must be both rated and marked on the required wiring diagram.

In the case of equipment for direct switching of individual electric motors, the indication of a rated operational current may be replaced (or supplemented) by an indication of the maximum rated power output, at the rated operational voltage of the motor for which the equipment is intended to be connected.

### 3.2.10 Pressure Sensing Elements

A pressure sensing element is a critical component of a pressure switch that is used to signal the controller to start or stop the fire pump in response to water pressure changes in the fire protection system, or used to control the pressure regulation in variable speed or pressure limiting controllers or drivers. The fire pump controller shall provide adequate control means (i.e. voltage, current and/or power) for the pressure sensing element to operate under foreseeable abnormal conditions.

3.2.10.1 These devices are typically, but not limited to, pressure transducers, pressure transmitters, or mechanical pressure switches of the bourdon tube type. Bourdon tube devices may be of the snap acting switch type or the more common mercury contact type devices.

3.2.10.2 Pressure transducers shall be of the internal or external amplifier type. External amplifier types are typically solid state strain gage element devices. Internal amplifiers types can be either voltage or current output type.

- a. At the controller rated input voltage, voltage output type transducers shall be supplied by the controller with the power supply voltage within the range of the voltage power input rating of the transducer. The same shall be true when the controller is supplied with 85 percent of its rated input voltage; and when the controller is supplied with 110 percent of its rated input voltage.
- b. Current output types shall be supplied by the controller with at least 125 percent of the minimum compliance voltage rating of the transducer. The output burden (sensing

resistor) shall be no higher than 80 percent of the rated maximum burden resistance. This shall also be met when the controller is supplied with 85 percent of its rated input voltage; and when it is supplied with 110 percent of its rated input voltage.

- 3.2.10.3 The minimum diameter orifice size of a pressure sensing element in contact with water shall be 1/8 in. (3.2 mm). This is necessary to prevent water particulates from clogging the inlet to the sensor and interfering with the pressure sensing operation.
- 3.2.10.4 Pressure transducers are for factory installation only in Certified fire pump controllers. The controller instruction manual shall provide instructions for setting the start and stop pressures for the fire pump.
- 3.2.10.5 The pressure transducer or transmitter shall be field replaceable.
- 3.2.10.6 Suitable provision shall be made for relieving pressure to the pressure-actuated switch to allow testing of the operation of the controller and the pumping unit.
- 3.2.10.7 For all pump installations, each fire pump controller shall have its own individual pressure sensing line. When used, each pressure maintenance (jockey) pump controller shall have its own individual pressure sensing line.
- 3.2.10.8 The pressure-sensing line connection for each pump shall be made between that pump's discharge check valve and discharge control valve, as follows:
  - a. All pressure components, fittings, connection and piping shall be brass, rigid copper or Series 300 Stainless Steel pipe or tube and the fittings shall be 1/2 in. (15 mm) nominal size.
  - b. There shall be two check valves installed in the pressure-sensing line at least 5 ft. (1.5 m) apart with a nominal 0.094 in. (2.4 mm) hole drilled in the clapper to serve as dampening. The use of two ground face union orifices per ANSI/NFPA 20, in lieu of drilled check valves, is not recommended.
  - c. For variable speed pressure limiting control, a 1/2 in. (15 mm) nominal size inside diameter pressure line shall be connected between the pump discharge flange and the discharge control valve.
- 3.2.10.9 There shall be no shutoff valve in the pressure-sensing line.
- 3.2.10.10 The controller shall have an external means for connecting the 1/2 in. (15 mm) nominal pressure sensing line.
- 3.2.10.11 There shall be no shutoff devices in the controller. This includes the entire path between the external pressure-sensing line connection and the pressure switch or transducer. This includes any and all valves and solenoids. Three way solenoid valves which include the path to the pressure switch or controller are allowed under the following conditions:
  - a. Three way valve must be wired such that the failure of the solenoid circuit does not prevent normal controller starting and operation;
  - b. Three way valve must be fully ported 1/2 inch (15 mm) diameter nominal pipe size and have internal passages of 1/8 inch (5 mm) diameter or larger, and;
  - c. Three way valve must be constructed of corrosion resistant material.
- 3.2.10.12 Diesel drive controllers shall include a test drain solenoid to accomplish both weekly and manual hydraulic pressure loss simulated starting.

3.2.10.13 Pressure switch actuation at the low adjustment setting shall initiate pump starting sequence, if the pump is not already in operation.

### 3.2.11 Shipping Fire Pump Controllers

All fire pump controllers shall be tested at the factory as one complete unit by the manufacturer, and transported and installed at the final destination as one complete unit with the following exception:

If access to the pump room is too small to accommodate the complete fire pump controller unit, the controller manufacturer, under special agreement with the end user, (not the installing contractor), may transport the unit in no more than three separate and self-contained pieces in accordance with UL 891, *Standard for Safety for Switchboards* and reassemble the complete unit on-site. The controller manufacturer must provide factory trained and certified personnel to reassemble the complete controller unit in the field. Field agents outside the direct employment of the controller manufacturer are not allowed. The separate controller pieces must be specifically designed for field reassembly and the complete controller unit must be tested in the field by factory trained and certified personnel after reassembly.

## 3.3 Markings

### 3.3.1 General

3.3.1.1 All markings shall be indelible and easily legible. All markings shall be in the appropriate language, as necessary, for the country in which the fire pump controller will be installed.

3.3.1.2 Marking of the manufacturer's name or trade mark and type designation or serial number is mandatory on the equipment and preferably on the nameplate, if any, in order to permit the complete data to be obtained from the manufacturer.

**Note:** In the USA and Canada, the rated operational voltage  $U_e$  may be marked as follows:

- a. on equipment for use on three-phase – four-wire systems, by both the value of phase-to-earth voltage and that of phase-to-phase voltage, i.e. 277/480 V;
- b. on equipment for use on three-phase – three-wire systems, by the value of phase-to-phase voltage, i.e. 480 V. On equipment which does not make use of a neutral, the phase-to-phase voltage marking is sufficient. The same applies to corner ground and ungrounded delta (three wire) systems. The same applies to four wire (center tapped) delta systems, such as 240/120/208 V A.C. systems.
- c. Special care is needed for controllers intended for use on corner ground or ungrounded systems. Ungrounded systems shall be considered as corner grounded systems regarding voltages seen by the controller.
- d. On corner ground or ungrounded systems or on four wire (center tapped) systems, the surge arrester circuitry shall be designed and rated for such systems on a continuous duty basis.

3.3.1.3 Controllers shall be marked, in a position visible after installation, with the following information:

- a. manufacturer's name or trade mark;
- b. Type designation or product identification number;
- c. Enclosure NEMA Type rating or IEC IP Code;
- d. Reference "IEC 62091", if the manufacturer is in compliance with this standard and

- as verified by the certification agency;
- e. “Electric Fire Pump Controller” or “Diesel Engine Fire Pump Controller” or “High Voltage Fire Pump Controller”;
- f. Non-pressure actuated fire pump controller (not required if not equipped with water pressure control);
- g. When the electric fire pump controller is provided with an automatic power transfer switch, the label “Fire Pump Power Transfer Switch” shall be located on the transfer switch;
- h. Rated maximum operating pressure;
- i. Rated controller ambient low operating temperature, and rated maximum ambient operating temperature; and,
- j. Complete instructions covering the operation of the controller
- k. Direction of movement of the manual emergency actuator, if applicable;
- l. Indication of the position of the manual emergency actuator;
- m. The certification agency’s mark of conformity, and other agency certification markings if applicable; and,
- n. Terminal identification and marking.

3.3.1.3.1 The following identifications shall be installed on the controller, preferably on the nameplate and visible during installation, stating:

- a. That no ancillary apparatus (i.e. jockey (make-up) pump) shall be connected to the fire pump controller;
- b. That only those devices indicated on the controller diagram(s) shall be connected to the controller;
- c. EMC rating for environment A, B or A and B;
- d. Type of system earthing for which the assembly is designed; and,
- e. Short circuit rating (see 3.3.1.4).

**Note:** The purpose of these identifications is to provide the user with additional application information.

#### 3.3.1.4 Prospective short circuit current

Electric fire pump controllers (normal and alternative power side when equipped with power transfer switch) shall be marked as follows:

“SUITABLE FOR USE ON A CIRCUIT CAPABLE OF DELIVERING NOT MORE THAN <RATED CURRENT> AMPERES RMS AT <RATED VOLTAGE> VOLTS AC”

The rated current and voltage values shall be indicated.

The prospective short circuit current marked value shall be equal to the conditional short circuit current value according to the performance requirements in this standard.

#### 3.3.1.5 Components

Each operating component of a controller shall be marked to plainly indicate an identification symbol appearing on the electrical schematic diagram. The markings shall be visible when the enclosure is open after installation of the controller. Power components shall also be marked with the appropriate listing agency such as UL, CSA, or recognized IEC Laboratory.

### 3.3.2 Marking for specific components and controllers

#### 3.3.2.1 Disconnecter (Isolating Switch)

A disconnecter shall be marked with the signal word “WARNING” and the following statement (or equivalent):

“RISK OF ELECTRIC SHOCK – DO NOT OPEN OR CLOSE THIS DISCONNECTOR WHILE THE FIRE PUMP CONTROLLER-SHORT CIRCUIT PROTECTIVE DEVICE IS IN THE CLOSED POSITION”

If the disconnecter is rated with sufficient fault-make, load-break capacity or when the disconnecter is prevented from being neither opened nor closed while the Fire Pump Controller-short circuit protective device is closed (i.e. isolating switch and circuit breaker are interlocked), the warning label shall not be required. When omitted, the label shall be replaced with an instruction label which directs the order of operation.

#### 3.3.2.2 Fire Pump Controller-Short Circuit Protective Device (SCPD)

The short circuit protective device shall be provided with an information plate with the legend in letters not less than 10 mm high:

“FIRE PUMP CONTROLLER-SHORT CIRCUIT PROTECTIVE DEVICE – SWITCHING MEANS”

or as commonly used in North America:

“CIRCUIT BREAKER – DISCONNECTING MEANS”

The information plate shall be located on the outside of the controller enclosure adjacent to the switching means for operating the Fire Pump Controller-short circuit protective device.

#### 3.3.2.3 Pressure Transducer or Transmitter

A pressure transducer/transmitter shall be permanently marked on the exterior of the device to include the name and address of the manufacturer, distinctive type or model number, serial number, pressure range, electrical ratings and date of manufacture. All markings shall be clearly visible, legible and durable.

#### 3.3.2.4 Enclosure

The enclosure of a controller shall be marked with the NEMA type rating or IEC IP Code indicating the degree of protection against ingress (see Appendix E). When a water pressure actuated controller is intended for outdoor use, a marking shall be provided on the enclosure indicating that the controller shall be used only where the temperature of the water in the pressure sensing means and pressure sensing line cannot fall below +39 °F (+4 °C).

#### 3.3.2.5 Field Wiring

Terminals for user connection intended to be used only with copper conductors shall be marked to indicate the use of copper conductors only. All the field wiring terminals provided in the controller shall be plainly marked to correspond with the field connection diagram provided with the controller.

#### 3.3.2.6 Electric Fire Pump Controller

A controller with this classification shall be marked “ELECTRIC FIRE PUMP CONTROLLER”.

The following ratings and electrical characteristics apply for electric fire pump controller with or without a fire pump power transfer switch:

- a. Rated operational voltage and number of phases, with symbol **O** , if not useful for IT systems (IT symbol not required in North America);
- b. Rated motor power in horsepower or kilowatts and/or rated motor FLC;
- c. Rated frequency/frequencies or the indication “D.C.” or the symbol  $\text{---}$ ;
- d. Rated conditional short circuit current for each source;
- e. Maximum water sensing pressure

3.3.2.6.1 Controllers for use with electric motor driven fire pumps and intended for use as service equipment shall be marked “Suitable for Use as Service Equipment” on the outside of the controller enclosure. The markings shall be provided separately or as part of the nameplate containing the manufacturer’s name or trademark, and other ratings. When provided on a separate label, the markings shall include the manufacturer’s name or trademark. A separate label containing the marking “Service Disconnect” shall be shipped loosely with instructions indicating that the label is to be applied on the outside of the enclosure adjacent to the operating handle of the isolating switch, when the isolating switch is provided. When an isolating switch is not provided, the label shall be applied adjacent to the operating handle of the circuit breaker.

**Note:** The “Service Disconnect” label is not applicable for Canada which employs a service box ahead of the controller for this application.

### 3.3.2.7 Electric Fire Pump Controller Combined With Power Transfer Switch

- a. Where the power transfer switch consists of a self-contained power switching assembly, such assembly shall be housed in a barriered compartment of the fire pump controller or in a separate enclosure attached to the controller and marked “Fire Pump Power Transfer Switch”.
- b. The fire pump controller and transfer switch shall each have a cautionary marking to indicate that the isolation (disconnect) switches, on both the controller and automatic transfer switch, are to be opened before servicing the controller, transfer switch, or motor.

### 3.3.2.8 Reserved for future use

### 3.3.2.9 High Voltage Electric Fire Pump Controller

A controller with this classification shall be marked:

“HIGH VOLTAGE FIRE PUMP CONTROLLER”.

Additional marking requirements are as listed for electric fire pump controllers in Section 3.3.2.6 and 3.3.1.

### 3.3.2.10 Stand-Alone Fire Pump Power Transfer Switches

A fire pump power transfer switch shall be marked “FIRE PUMP POWER TRANSFER SWITCH”. The letters shall be at least 1 in. (25 mm) in height.

When a circuit breaker is not provided on the line side of the alternate input terminals of the transfer switch, the following marking is required: “CAUTION: This controller not suitable for use with alternate/second utility source or generator with current capacity greater than 225

percent of the fire pump motor full-load current rating,” or equivalent.

#### 3.3.2.11 Diesel Engine Fire Pump Controller

A diesel engine fire pump controller shall be marked “DIESEL ENGINE FIRE PUMP CONTROLLER”.

Controller terminals shall be numbered as indicated in Table A.1.

The diesel engine fire pump controller manufacturer shall provide specifications and instructions for the size of wire and the maximum distance for the connections between the controller and the diesel engine.

The following ratings and electrical characteristics apply:

- a. Rated operational A.C. voltage;
- b. Rated operational supply current;
- c. Rated frequency/frequencies;
- d. Battery voltage;
- e. Type of battery;
- f. Engine earth polarity;
- g. Engine stopping method (energize fuel solenoid or de-energize fuel solenoid);
- h. Maximum water sensing pressure.

#### 3.3.2.12 Additive/Foam Pump Controllers

##### 3.3.2.12.1 Electric additive/foam pump controllers

Electric additive/foam pump controllers shall be marked either “ELECTRIC ADDITIVE PUMP CONTROLLER” or “ELECTRIC FOAM PUMP CONTROLLER” depending on the jurisdictional requirements. All other markings are per Sections 3.3.2.6 and 3.3.1.

##### 3.3.2.12.2 Diesel engine additive/foam pump controller

Diesel engine additive/foam pump controllers shall be marked either “DIESEL ENGINE ADDITIVE PUMP CONTROLLER” or “DIESEL ENGINE FOAM PUMP CONTROLLER” depending on the jurisdictional requirements. All other markings are per Sections 3.3.2.11 and 3.3.1.

#### 3.3.3 Variable Speed electric motor driven fire pump controller

- 3.3.3.1 In addition to the markings required for electric motor driven fire pump controllers, the variable speed controller and drive shall also be marked with the maximum ambient temperature rating. This is the temperature, as verified by the methods in this standard, which keep the VFD within its maximum rated ambient temperature rating.

**Note:** This rating is needed for safe and reliable operation.

- 3.3.3.2 The variable speed controller shall have a mounted plate or permanent label inside of the controller enclosure that identifies the following parameters:

- a. The system Set Point Pressure
- b. The Pump Start Pressure
- c. The Pump Stop Pressure (This setting is required whether the controller is arranged for Manual Stop or for Automatic Stop operation. Certified controllers shall have a means to disable and lock-out the automatic shutdown feature, and the controller shall have a clear visual indication that the automatic shutdown feature is disabled or

enabled.)

**Note:** Whether the controller is arranged for manual stop or automatic stop, the pump start pressure determines when the pressure switch timer initiates counting down to initiate a mode change to full speed running.

### 3.3.4 Electrical diagrams and instructions (All Controllers)

#### 3.3.4.1 Diagrams

An electrical schematic diagram, indicating all internal wiring, circuits, test terminals, provisions for alarm circuits, all power supplies and other components, shall be permanently attached to the inside of the controller enclosure.

- a. All the field wiring terminals provided in the controller shall be plainly marked to correspond with the field connection diagram provided with the controller.
- b. Each operating component of the controller shall be marked to plainly indicate an identifying number referenced on the electrical schematic field connection diagram. The marking shall be located so as to be visible after installation.
- c. For external diesel engine connections, the field connection terminals shall be commonly numbered between the controller and engine terminals.

#### 3.3.4.2 Operating instructions

Instructions for starting and stopping the pump motor and for emergency operation of the fire pump shall be provided on the front of the controller in a position visible after installation.

**Note:** It shall be taken into account that instructions may be required to be read quickly in poor visibility environments (i.e. in a smoky atmosphere).

### 3.3.5 Instructions for installation, operation and maintenance

The manufacturer shall specify in his documents or catalogues the conditions for installation, operation and maintenance (including spare parts) of the controller. This information shall include, as a minimum, any specific information on connecting conductor size.

### 3.3.6 Normal service, mounting and transport conditions

### 3.3.7 Clause 6 of IEC 60947-1 and ANSI/UL 508 applies with the following additional requirements.

#### 3.3.7.1 Water Temperature

When a water pressure actuated controller is intended for outdoor use, a marking shall be provided on the enclosure indicating that the controller shall be used only where the temperature of the water in the pressure sensing means and pressure sensing line cannot fall below +39 °F (+4 °C).

#### 3.3.7.2 Humidity

For equipment intended for use within an enclosure or provided with an integral enclosure, the relative humidity of the air shall not exceed 50 percent at a maximum temperature of 104 °F (40 °C). Higher relative humidities may be permitted at lower temperatures [i.e. 90 percent humidity at 68 °F (20°C)]. Means shall be taken to avoid condensation within a controller when ever it is likely to occur, (any season or time of day). Such means may include space heaters controlled by humidistats or thermostats.

**Note:** Operating such heaters at half of their voltage rating improves safety and reliability of the heater.



#### 3.3.7.3 Degrees of Pollution

Unless otherwise stated by the manufacturer, fire pump controllers are intended for use in pollution degree 3 environmental conditions, as defined in 6.1.3.2 of IEC 60947-1. However, other pollution degrees may be considered to apply depending upon the environment. For variable speed controllers, the controller shall provide no worse than the pollution degree rating of the VFD.

#### 3.3.7.4 EMC considerations

Fire pump controllers shall be suitable for use in environment A or/and B. Information shall be provided by the manufacturer to advise the user on the measures to be taken concerning EMC.

### 3.4 Calibration

3.4.1 Each piece of equipment used to verify the test parameters shall be calibrated within an interval determined on the basis of stability, purpose, and usage. A copy of the calibration certificate for each piece of test equipment is required. The certificate shall indicate that the calibration was performed against working standards whose calibration is certified and traceable to an acceptable reference standard and certified by an ISO/IEC 17025 accredited calibration laboratory. The test equipment shall be clearly identified by label or sticker showing the last date of the calibration and the next due date. A copy of the service provider's accreditation certificate as an ISO/IEC 17025 accredited calibration laboratory should be available.

3.4.2 When the inspection equipment and/or environment is not suitable for labels or stickers, other methods such as etching of control numbers on the measuring device are allowed, provided documentation is maintained on the calibration status of this equipment.

### 3.5 Tolerances

Tolerances on units of measure shall be as described in Appendix G, unless otherwise specified.

## 4 CONSTRUCTIONAL, FUNCTIONAL AND PERFORMANCE REQUIREMENTS

### 4.1 Constructional requirements for type tested devices for electric motor and diesel engine fire pump controllers

#### 4.1.1 General

- 4.1.1.1 Controllers shall be completely assembled, wired and tested by the manufacturer before installation.
- 4.1.1.2 The constructional requirements for the type-tested device shall be verified by examining the manufacturer's certification records and by visual inspection during the set-up for exercising the fire pump controller test protocol. When certification records are not provided, testing shall be arranged for the device as prescribed by this standard.
- 4.1.1.3 Fire pump controllers shall not be used as a junction box to supply other equipment and shall not be used as service equipment for other devices or loads. An exception is allowed for diesel engine fire pump controllers as explained in Section 4.7.2.6.b.
- 4.1.1.4 All electrical power components shall comply with their own relevant NEC or IEC product standard, and shall have been examined by UL, CSA or acceptable IEC Laboratory.
- 4.1.1.5 An electric fire pump controller shall not have an externally accessible hand operated selector switch (i.e. Auto-Off-Manual or Hand-Off-Auto) that interferes with the operation of the isolation switch, circuit breaker, manual shutdown pushbutton or emergency run mechanical control when the controller is in the automatic mode.

#### 4.1.2 Enclosures

A fire pump controller assembly or panel shall be securely mounted in an enclosure that protects the equipment against limited amounts of falling water and dirt. The enclosure shall be constructed to provide strength and rigidity required to resist the abuses to which it is subjected, without total or partial collapse resulting in a risk of fire, electric shock, or injury to persons due to reduction of spacings, loosening or displacement of parts, or other serious defects.

- 4.1.2.1 Enclosures for fire pump controllers shall comply with the national and jurisdictional requirements per UL 508, *Industrial Control Equipment*, CSA C22.2 No. 14, *Industrial Control Equipment*, NMX-J-235-1-ANCE, *Enclosure General Requirements*, and subclause 7.1.10 of IEC 60947-1, *Low-Voltage Switchgear and Controlgear - Part 1: General rules*.
- 4.1.2.2 Enclosures for fire pump controllers shall comply with the requirements for a NEMA environmental rating no lower than Type 2 per NEMA 250, *Enclosures for Electrical Equipment (1000 Volts Maximum)* or ANSI/UL 50, *Enclosures for Electrical Equipment Non-Environmental Considerations* (see Appendix E), or with the requirements for an IP designation code of no lower than IP31 according to Annex C of IEC 60947-1, *Low-Voltage Switchgear and Controlgear - Part 1: General rules* and IEC 60529, *Degrees of protection provided by enclosures (IP code)*.
- 4.1.2.3 The enclosure shall be so constructed so as to maintain the minimum required pollution degree protection required throughout its service life.

4.1.3 Materials

All components which are installed within the fire pump controller enclosure shall be mounted in accordance with their manufacturer’s instructions on a supporting structure of noncombustible materials. The assessment criteria for non-combustible materials, in accordance with IEC 60695-11-10, Fire hazard testing – Part 11-10: *Test flames – 50 W horizontal and vertical flame test methods*, are given in Table 4.1.2 below. Flammability of materials shall be verified by the procedure stated in Annex M of IEC 60947-1 *Low-Voltage Switchgear and Controlgear - Part 1: General rules*, or ASTM D 3874, Standard Test Method for Ignition of Materials by Hot Wire Source.

Table 4.1.2 – Assessment criteria

<b>Test Method</b>	<b>Criteria</b>
<b>Horizontal burning</b>	<b>Method A, HB40</b>
<b>Vertical burning</b>	<b>Method B, V-0</b>
<b>Horizontal flame (FH)</b>	<b>HF-1</b>

4.1.4 Current-Carrying Parts and Their Connections

Subclause 7.1.2 of IEC 60947-1, *Low-Voltage Switchgear and Controlgear - Part 1: General rules*, applies with the following additions.

4.1.4.1 Service Equipment

Controllers for use with electric motor driven fire pumps and intended for use as service equipment shall be fitted for direct connection to incoming premises power supply conductors. Requirements for circuits supplying the controller are given in IEC 60364, *Electrical installations of buildings*, UL 508, *Industrial Control Equipment* and UL 869A, *Reference Standard for Service Equipment*. The controller shall be equipped to accommodate the service conductors, the earthing electrode conductor and earthing (bonding) connection. Means shall be made available for the additional grounding, bonding and/or earthing conductors as well as motor conductors as required by the national regulations of the country in which the fire pump controller is to be used. Said means may be by way of options or optional kits.

4.1.4.2 Main circuits

All busbars for field connection shall be readily accessible after installation of the controller and arranged so the disconnection of the external circuit conductors shall not be required for maintenance. Busbars, wiring, and wiring terminals of the main circuit shall be sized for continuous duty in accordance with the rated operational currents. Conductors that are in a circuit only during the motor starting period shall be sized according to their own intermittent duty cycle. Conductors and devices in the main circuit shall be capable of withstanding two 20 second locked-rotor tests spaced at 1 minute intervals without sustaining damage. Fire pump controllers shall not be equipped to permit the connection of any ancillary apparatus to the fire pump controller.

4.1.5 Clearance and spacing distances

4.1.5.1 Electrical spacings through air, over surface and between uninsulated live parts and the enclosure walls shall be at least those specified in Table A.3.

4.1.5.2 For printed circuit wiring boards, the minimum spacings shall be as specified in Table A.4.

4.1.5.3 The spacings at a field-wiring terminal are to be measured with wire connected to the terminal as in service. The connected wire is to be the next larger size than normally required if the terminal will accommodate it, or if the equipment is not marked to restrict its use.

- 4.1.5.4 The spacings specified in Table A.3 for devices having limited rating shall apply to:

Devices rated 1 hp (0.75 kW) or less; 720V•A or less (break pilot duty); or not more than 15A at 51-150V, 10A at 151-300V, or 5A at 301-600V; or any combination thereof; these same devices, when multipole and controlling more than one load, provided that the total load connected to the line at one time does not exceed 2 hp (1.5 kW), 1440V•A, or have a current rating greater than 30A at 51-150V, 20A at 151-300V, or 10A at 301-600V, and provided also that the loading on any one pole does not exceed its marked rating.

- 4.1.5.5 In a circuit involving voltages of 50V or less spacings at field-wiring terminals shall be permitted to be 0.125 in. (3.2 mm) through air and 0.25 in. (6.3 mm) over surface.

- 4.1.5.6 In a circuit involving voltages of 50V or less, other than field wiring terminals, the spacings shall be 0.06 in. (1.6 mm) through air or over surface, provided that the insulation and clearances between such circuits and any circuits of more than 50V are in accordance with the requirements for the higher voltage circuit.

#### 4.1.6 Insulating Barriers

- 4.1.6.1 An insulating barrier or liner used as the sole separation between uninsulated live parts and grounded dead metal parts, including the enclosure, or between uninsulated live parts of opposite polarity shall be of a material that is intended for the mounting of uninsulated live parts, and shall not be less than 0.028 in. (0.71 mm) thick. An exception is fiber. Fiber less than 0.028 in. (0.71 mm) thick may be used as the sole separation between the enclosure and an uninsulated metal part electrically connected to a grounding conductor.

- 4.1.6.2 An insulating barrier or liner that is used in addition to an air space in place of the required spacing through air shall be at least 0.028 in. (0.71 mm) thick. When the barrier or liner is of fiber, the air space shall not be less than 1/32 in. (0.8 mm), and when the barrier or liner is of other material that is not capable of being used for the support of uninsulated live parts, the air space provided shall be acceptable for the application. An exception is a barrier or liner that:

- a. Is used in addition to an air space, where the air space is not less than one-half the required spacing through air;
- b. Is not less than 0.013 in. (0.33 mm) thick;
- c. Is of a material that is intended for the support of uninsulated live parts;
- d. Has the mechanical strength required to withstand mechanical damage;
- e. Is held in place; and
- f. Is located so that it is not adversely affected by operation of the equipment in service.

- 4.1.6.3 Insulating material having a thickness less than that specified in 4.16.1 and 4.16.2 is capable of being used when subjected to the Barrier Dielectric Strength Test or the material is selected in accordance with Table A.5.

#### 4.1.7 Field Wiring Terminals

- a. A fire pump controller shall be provided with wiring terminals or leads for connection of conductors having a continuous current-carrying capacity not less than 125 percent of the rated operational motor current (Subclause 7.1.7 of IEC 60947-1), or 125 percent of the full-load motor current specified in Table A.6 for the horsepower rating.
- b. In the case of power conversion equipment (i.e. such as variable frequency drives) in which the input current is different from rated operational motor current (motor full-load current), the continuous current-carrying capacity shall be based upon 125 percent of the maximum rated input

current.

#### 4.1.7.1 Wire Size

- a. A fire pump controller shall be provided with wiring terminals or leads for connection of conductors having a wire size not less than No. 10 AWG (5.3 mm<sup>2</sup>) for service use and not less than No. 14 AWG (2.1 mm<sup>2</sup>) for control circuits. (See Table A.12 for field conductor ampacities.)
- b. Field wiring terminals for a diesel engine fire pump controller shall be suitable for use with stranded wire.

#### 4.1.7.2 All wiring terminals intended for field connection shall:

- a. Be evaluated in accordance with national requirements such as CSA 22.2 No. 65 & No. 158, UL 486E & 1059, and IEC 60947 and marked for the wire size or range;
- b. Be part of a device evaluated and marked for the wire size or range; or
- c. Comply with the secureness and pullout requirements of 4.1.7.4 for the next larger size conductor than that specified in 4.1.7.1, unless the equipment is marked to restrict its use to only the smaller size conductor.

#### 4.1.7.3 A terminal to which field wiring is to be connected shall be a pressure wire connector.

A terminal to which No. 10 AWG (5.3 mm<sup>2</sup>) or smaller wiring connections are to be made may consist of a clamp or wire-binding screw with a terminal plate having upturned lugs or the equivalent to hold the wire in position.

#### 4.1.7.4 A field-wiring pressure wire connector provided with or specified for use with industrial control equipment shall comply with the applicable national requirements such as CSA 2.2, UL 486A, 486E & 1059, and IEC 60947.

#### 4.1.7.5 A wire-binding screw to which field-wiring connections are made shall be No. 8 or larger.

A No. 6 screw may be used at a terminal intended only for connection of a No. 14 AWG (2.1 mm<sup>2</sup>) conductor or smaller.

#### 4.1.7.6 A terminal plate tapped for wire-binding screw shall be of metal not less than 0.030 in. (0.76 mm) thick for a No. 14 AWG (2.1 mm<sup>2</sup>) or smaller wire, and not less than 0.050 in. (1.27 mm) thick for a wire larger than No. 14 AWG (2.1 mm<sup>2</sup>). There shall be at least two full threads in the plate.

#### 4.1.7.7 For a terminal plate formed from stock having the required thickness specified in Section 4.1.7.6, one method of complying with the thread requirement of Section 4.1.7.6 is to have the metal extruded at the tapped hole for the binding screw to provide two full threads.

#### 4.1.7.8 A wire-binding screw shall thread into metal.

### 4.1.8 Grounding

#### 4.1.8.1 All controllers shall have provisions for grounding all non-current-carrying metal parts that are exposed or that are located in a position to be contacted by persons during normal operation or adjustment of the equipment and that are capable of becoming energized. Additional jurisdictional requirements may also apply such as CSA 22.2 No. 0.4 in Canada.

#### 4.1.8.2 The grounding and bonding terminology used in this standard are in accordance with NFPA 70 as depicted in Figure B-7, with the corresponding CEC and ANCE terms also provided.

- 4.1.8.3 Controllers shall be provided with a terminal or an equivalent means for connecting an equipment grounding conductor except as provided in (a) below. A terminal shall be sized for a grounding conductor as specified in Table A.8.
- a. A terminal need not be provided with a controller that is marked to indicate the pressure wire connector or component terminal kits that are intended for use with the controller. A wire connector of the type mentioned is to be installed in the equipment at the factory with instructions, if required, for proper connection to the conductor. A terminal kit shall be described in the instructions by model number and manufacturer's name.
- 4.1.8.4 A wire-binding screw intended for the connection of a field-installed equipment grounding conductor shall have a green colored head that is hexagonal, slotted, robertson, phillips, allen, Torx™ or any combination.
- 4.1.8.5 A terminal intended for connection of an equipment grounding conductor shall be plainly identified with the symbol

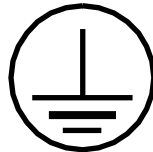

(IEC Publication 60417, Symbol 5019), or



(IEC Publication 60417, Symbol 5017)

or with "G," "GR," "GRD," "Ground," "Grounding," or other equivalent marking.

#### 4.1.9 Wire Bending Space

- 4.1.9.1 The distance between the end of a pressure wire connector or terminal block for connection of a field installed wire, and the wall of the enclosure toward which the wire is directed shall not be less than that indicated in Table A.2. The distance is to be measured in a straight line from the center of the opening in the connector, in the direction in which the wire leaves the terminal, perpendicular to the enclosure wall.
- 4.1.9.2 The required bending space is based on the size of field wire to be connected to the connector or terminal in accordance with Section 4.1.7, Field Wiring Terminals.

#### 4.1.10 Internal Wiring, Busbars, and Connections

- 4.1.10.1 Insulated conductors shall be suitable for the service intended with respect to voltage, temperature, and grouping. Conductors shall be copper and shall not be smaller than No. 9 AWG (6.6 mm<sup>2</sup>). The temperature rating shall be not less than 194 °F (90 °C) unless investigation proves the suitability of other conductors.
- 4.1.10.1.1 The requirements of 4.1.10.1 apply only to the wiring furnished on or in industrial control equipment as a part of the equipment. They do not apply to the supply wiring run to control equipment, to motors, or to other apparatus.

- 4.1.10.1.2 For motor and control-circuit applications, the use of Table A.9 as a guide in selecting the conductor sizes in a controller does not obviate the need to perform temperature testing on the wire per CSA 22.2 No. 14 Industrial Control Equipment or UL 508 Industrial Control Equipment.
- 4.1.10.1.3 Conductors that are in a circuit only during the motor starting period are not required to be sized for continuous duty but shall be sized according to their duty cycle.
- 4.1.10.2 Notwithstanding clause 4.1.10.1 above, conductors smaller than No. 9 AWG (6.6 mm<sup>2</sup>) shall be permitted for wiring of printed circuit boards and interconnecting wiring between electronic modules and subassemblies.
- 4.1.10.3 Conductors in an assembly intended for use in a complete enclosure shall be insulated for the highest voltage normally occurring between such conductors unless the wires are grouped so as to segregate the several voltages.
- 4.1.10.4 Wires shall be supported or secured or otherwise run in suitable raceways, in order that they will not come into contact with moving parts or rest on sharp edges or projections that might cause abrasion of the insulation. Wires shall be of flexible or extra-flexible construction where they make connection to electrical equipment mounted on a hinged door. If the flexing section of the wiring is liable to come in contact with grounded metal parts, that portion of the wiring shall be given additional protection with wrappings of tape or the equivalent or enclosed in nonmetallic flexible tubing or conduit.
- 4.1.10.5 Additional insulation is not required if the Wire Flexing Test is completed without evidence of damage to the wiring.
- 4.1.10.6 Internal wiring shall not be in contact with bare live parts of opposite polarity or with bare live parts of other circuits.
- 4.1.10.7 A bare conductor, including pigtails and coil leads, shall be supported so that the spacings required elsewhere in this standard will be maintained unless covered by suitable insulating sleeving or tubing.
- 4.1.10.8 All busbars and connections shall be readily accessible after installation of the controller.
- 4.1.10.9 All busbars and connections shall be arranged so that disconnection of the external circuit conductors will not be required.
- 4.1.10.10 Direct access to fuses shall be provided.
- 4.1.10.11 Clamps and guides, either metallic or nonmetallic, used for routing stationary internal wiring shall be provided with smooth, well-rounded edges. The clamping action and bearing surface shall be such that abrasion or cold flow of the insulation does not occur. Auxiliary nonconducting mechanical protection shall be provided under a metallic clamp that exerts pressure on a conductor having thermoplastic insulation less than 1/32 in. (0.8 mm) thick and having no overall braid.
- 4.1.10.12 Insulated grounding and bonding conductors shall be identified by the color green with or without one or more yellow stripes. No other leads shall be so identified in the field wiring area.
- 4.1.10.13 All splices and connections shall be mechanically secure and shall provide electrical continuity.

4.1.10.14 Electrical connections shall be soldered, welded, crimped, or otherwise securely connected. A soldered joint shall be mechanically secure before soldering. Crimped connections shall use listed lugs or splices and be applied with the lug manufacturer's recommended tools and/or dies. Such connections shall be, as a minimum, gas tight.

**Note:** Gas Tight crimps are essential for reasonable service life and to accommodate temperature and humidity fluctuations and cycles.

4.1.10.15 A printed wiring board joint is not required to be mechanically secure before soldering.

4.1.10.16 A lead is considered to be mechanically secure when it is:

- a. Wrapped at least halfway (180 degrees) around a terminal;
- b. Provided with at least one right angle bend when passed through an eyelet or opening; or,
- c. Twisted with other conductors.

4.1.10.17 If stranded internal wiring is connected to a wire-binding screw, the construction shall be such that loose strands of wire cannot contact other uninsulated live parts not always of the same polarity as the wire, and de-energized metal parts. This can be accomplished by any acceptable means including use of machine- or tool-applied pressure terminal connectors, soldering lugs, or crimped eyelets, or soldering all strands of the wire together.

4.1.10.18 A splice shall be provided with insulation equivalent to that of the wires involved.

4.1.10.19 In determining if splice insulation consisting of coated-fabric, thermoplastic, or other types of tubing is acceptable, consideration is to be given to electrical and mechanical properties including dielectric voltage-withstand ability, heat resistance, and moisture resistance. Thermoplastic tape shall not be wrapped over a sharp edge or connection.

#### 4.1.11 Actuators

##### 4.1.11.1 External controls

All switching equipment for manual use in connecting or disconnecting, or starting or stopping the motor shall be externally operable.

##### 4.1.11.2 Use of sensing devices

Sensing devices, such as undervoltage, phase loss, frequency sensitive, earth leakage protection, etc., shall not be connected in any manner that prevents the automatic and/or manual operation of the fire pump controller.

4.1.11.2.1 Sensors shall be permitted to prevent a three-phase motor from starting under single-phase conditions shall not cause disconnection of the motor when running at the time of a single-phase occurrence. Such sensors shall be monitored to provide a local visible alarm in the event of malfunction of the sensors. When single-phase (loss of phase) motor protection is provided:

- a. The failure of any circuit or component whose primary function is the detection, signaling, or response to a loss of phase of the power source shall not prevent the motor from electrically starting under restored power conditions.
- b. If the single phase loss condition occurs while the motor is running, any circuit or component whose primary function is the detection, signaling or



response to a loss of phase of the power source shall not interrupt the power to the motor, including low rpm and locked rotor conditions.

- c. The voltage threshold (drop out) for any circuit or component whose primary function is protection of the motor from a loss of phase of the power source shall not exceed 70 percent of the nominal line voltage.
- d. When the motor is protected from a loss of phase of the power source, electrical starting capability shall be automatically restored within 10 seconds upon the restoration of power.

#### 4.1.12 Provisions for Use of Test Instruments

4.1.12.1 Provisions shall be made within the controller for the use of test instruments in the field after installation for verification of all line voltages and currents without disconnecting any conductors within the controller.

4.1.12.2 Means shall be provided on the exterior of the controller to read all line currents and all line voltages within  $\pm 5$  percent of full scale. See also Section 3.2.3.2 and Section 3.2.3.3.

#### 4.1.13 Auxiliary Circuits

An auxiliary circuit shall be provided with overcurrent protection in accordance with the requirements of ANSI/NFPA 70 National Electrical Code, Canadian Electrical Code Part I C22.1, or IEC 60947-1. Failure of auxiliary circuits shall not prevent the controller from starting the fire pump driver.

#### 4.1.14 Surge Arresters

4.1.14.1 A surge arrester, complying with ANSI/IEEE C62.1 or ANSI/IEEE C62.11 shall be installed from each line to ground. These devices shall be rated to suppress voltage surges above the rated line voltage of the controller. When recommended by the manufacturer, the surge arrester shall be protected by the required overcurrent protection. When surge arresters are installed downstream of a self protecting isolating switch, disconnect switch, disconnect or circuit breaker, the surge arrester shall be provided with overcurrent protection coordinated with upstream devices so as to prevent tripping of such devices for any surge within the rating of the surge arrester.

Exceptions:

- a. A controller rated in excess of 600V is not required to be provided with a voltage surge arrester.
- b. A voltage surge arrester is not required to be provided when the controller is capable of withstanding a 10 kV impulse in accordance with ANSI/IEEE 62.41, without damage.
- c. Surge arresters shall not be used with diesel fire pump controllers. This is required to avoid nuisance tripping of branch circuit protection (circuit breakers). Such tripping renders the battery charger inoperative.

## 4.2 Functional and performance requirements for components

### 4.2.1 General

All components required to start, run and protect the motor shall comply with their relevant IEC and NFPA 70 (NEC) product standards.

#### 4.2.2 Dielectric properties

The controller shall be capable of withstanding an impulse voltage withstand test without damage in accordance with overvoltage category IV of Table H.1 of IEC 60947-1 and UL 218 Section 30.

#### 4.2.3 Disconnecter/Isolating Switch

4.2.3.1 The disconnector/isolating switch shall be manually and externally operable, and comply with jurisdictional requirements of UL 98, CSA 22.2 No. 4, or IEC 60947. A molded case switch provided with self-protecting instantaneous short circuit overcurrent protection can also be used as a disconnector if the switch does not trip unless the circuit breaker in the same controller trips, in compliance with UL 489 or CSA 22.2 No. 5. Likewise, if an overcurrent protective device in accordance with Annex L of IEC 60947-2 is used as a disconnector, it shall be arranged and wired such that it does not trip unless the fire pump controller (FPC) short circuit protective device, in the same controller, has opened.

4.2.3.2 The disconnector/isolating switch shall have a continuous current rating that is at least 115 percent of the rated operational motor current  $I_e$ , or the motor rated full load current as determined from Table A.6; or, it shall be rated in horsepower or motor kilowatt at the voltage intended.

4.2.3.3 The disconnector/isolating switch shall be prevented from being opened or closed while the fire pump controller (FPC) short circuit protective device is closed. If a suitably rated disconnector is used, then the means to prevent opening or closing of the FPC-short circuit protective device shall not be needed. Likewise, a horsepower or kW rated motor circuit switch complying with CSA C22.2 No. 4 or UL 98 shall also be permitted to be used as the disconnector/isolating switch.

4.2.3.4 The disconnector/isolating switch operating handle shall be provided with a spring latch which shall be so arranged that it requires the simultaneous releasing of the latch in order to open or close the switch and shall be marked as per Section 3.3.2.1 of this standard.

4.2.3.5 For a construction with the disconnector/isolating switch and a circuit breaker (used as the FPC-short circuit protective device), so interlocked that the disconnector/isolating switch is not capable of being opened nor closed while the circuit breaker is closed, the latch and marking described in Section 3.3.2.1 above is not required.

#### 4.2.4 Overcurrent protective devices used within the FPC (FPC-short circuit and locked rotor protective devices)

##### 4.2.4.1 General

The motor circuit shall be protected by overcurrent protective devices in accordance with the relevant product standard (IEC 60947-2, UL 489 or CSA 22.2 No. 5) and this standard. The overcurrent protective device shall be connected directly to the load side of the disconnecting device with one pole connected to each ungrounded circuit conductor (see Figures B-1 and B-2). When the overcurrent protective device is a circuit breaker, the circuit breaker shall comply with UL 489 or CSA C22.2 No. 5.

**Note:** When the motor circuit is transferred to an alternate on-site power generator and is protected by an overcurrent device at the generator and meets the requirements of Section 3.2.8.1.4, the FPC-overcurrent protection within the fire pump controller is not required.

#### 4.2.4.2 Mechanical characteristics of the overcurrent-protective devices

The overcurrent-protective device in the FPC shall give a fireman the “second chance under fire conditions” to quickly place the controller back into service after the overcurrent protective device has opened. In order to accomplish that requirement, it must comply with all of the following:

- a. Manually and externally operable and resettable;
- b. Be externally visually-apparent of the tripped condition and be capable of quick restart by an electrically unqualified person (firemen are not often required to become “electrically qualified”, therefore manual operation must be electrically safe and intrinsically obvious in order to get the fire pump restarted);
- c. Require no need for tools or instruments nor replacement parts that may not be available;
- d. No thermal influence requiring waiting time to restore power to the motor;
- e. Ability to quickly and safely restore power to the pump motor in dark or smoky environments.

#### 4.2.4.3 Short circuit protection

The FPC-short circuit protective device shall have a continuous current rating not less than 115 percent of the rated operational current of the motor and be in compliance with all of the following:

- a. it shall be possible to restart the fire pump controller for operation immediately after tripping with the tripping characteristics thereafter remaining unchanged;
- b. an instantaneous short circuit protection shall be provided;
- c. the short circuit breaking capacity shall be compatible with the conditional short circuit current rating of the controller;
- d. the FPC-short circuit protective device shall be compatible with the normal and the emergency-run mechanical requirements (see 4.3.1.2) for starting the motor without tripping;
- e. the instantaneous short circuit protection shall be the minimum consistent with the ability to start the motor under all foreseeable conditions without tripping.

##### 4.2.4.3.1 Electrical characteristics of the circuit breaker disconnecting means (when used)

- a. Have a continuous current rating not less than 115 percent of the rated full load current of the motor;
- b. Have non-thermal type overcurrent sensing elements, if provided;
- c. Be of the instantaneous-only circuit-breaker type with an instantaneous trip setting of not more than 20 times the full load current to allow normal starting or emergency run mechanical starting of the motor without tripping;
- d. Be adequate to provide the short circuit rating of the controller, as determined by testing.
- e. Operation and tripping of the circuit breaker shall not be inhibited by low or missing voltage on any conductor.

#### 4.2.4.4 Locked rotor overcurrent protection

A locked rotor protective device shall be provided between the load side of the disconnecting device and the contactor, and shall be located within the fire pump controller (see Figures B-1, B-2, B-3, B-4 and B-5). No other overcurrent protective device shall be provided. It shall

have the following characteristics for a squirrel-cage induction motor:

- a. It shall be of the non-thermal time delay type having a tripping time between 8 seconds and 20 seconds at 600 percent of rated motor full-load current; and for energy efficient motors under 15 hp (10kW), between 8 seconds and 20 seconds at 720 percent of  $I_e$  (rated operational current), or the inrush current of the motor as declared by the motor manufacturer;
- b. It shall indefinitely carry 300 percent of  $I_e$ , or 300 percent of rated full-load current; For the purpose of certification, it shall have a tripping characteristic such that tripping shall not occur in less than 30 minutes at 300 percent of  $I_e$ , or 300 percent of rated full-load current;
- c. It shall provide visual means or markings on the device which clearly indicate that proper settings are installed;
- d. The overcurrent sensing elements shall be so constructed that it shall be possible to reset the device for operation immediately after tripping with the tripping characteristics thereafter remaining unchanged;  
**Note:** Shunt-trip means, or some other direct acting means, are preferred (see Figures B-1, B-2, B-3, B-4 and B-5).
- e. It shall be effective under all starting means;
- f. If a circuit breaker is used as the disconnecting device, then tripping shall be accomplished by opening the circuit breaker, and the circuit breaker shall be of the external manual reset type;
- g. If a common locked rotor protector is used in FPC's having more than one power source, the locked rotor protector shall reset its self before receiving power from the alternate source. The locked rotor protector trip signal is to be effective only to the circuit supplying the power;
- h. Low or missing voltage on any conductor shall not prevent or interfere with the requirements of (a) through (g) above;
- i. The locked rotor overcurrent protection shall be tested in accordance with this standard.

#### 4.2.5 Control circuits

An overcurrent protective device, other than the controller circuit breaker, shall not be provided in the control circuit.

#### 4.2.6 Short circuit behavior

Each fire pump controller shall have the ability to make and break the rated conditional short circuit current. The verification shall be made according to Section 5.7 of this standard.

#### 4.2.7 Full voltage starting means

4.2.7.1 Each fire pump controller shall be capable of making, breaking and carrying the motor currents resulting from direct on-line control of squirrel cage induction motors. In the European Community, where a contactor is used, it shall be in accordance with IEC 60947-4-1 with the following additional requirements:

- a. It shall meet the requirements of utilization category AC3;
- b. It shall withstand locked-rotor current as described in Section 5.14;
- c. It shall withstand 300 percent of  $I_e$  (of the fire pump controller) for 30 minutes;
- d. It shall have a thermal capacity to allow three 30 second starts separated by 30 second rest intervals in each hour for 2 hours.

4.2.7.1.1 In the European Community, where a motor semiconductor controller is used, it shall be in accordance with IEC 60947-4-2 with the following additional requirements:

- a. It shall meet the requirements of utilization category AC-53a;
- b. It shall withstand locked-rotor current as described in Section 5.14;
- c. It shall withstand 300 percent of  $I_c$  (of the fire pump controller) for 30 minutes.

These requirements shall be verified by testing, see Section 5.14.

4.2.7.2 For North America, a motor contactor that complies with UL 508 or CSA C22.2 No. 14 shall be of the magnetic type with a contact in each ungrounded conductor.

#### 4.2.8 Reduced voltage starting means

##### 4.2.8.1 General

Reduced voltage starting means are:

- a. Primary resistance;
- b. Primary reactor (or neutral reactor for controllers above 5,000 V A.C.);
- c. Autotransformer;
- d. Star-delta (Wye-delta), or Closed or Open Transition;
- e. Part winding;
- f. Semiconductor soft start/stop.

**Note:** Other starting and running methods will be considered on a case by case basis.

**Note:** Wye-Delta starting, although popular, is a misapplication for centrifugal pumps since they are always started under some amount of load. They have only 33 percent torque which is not enough to accelerate a fully loaded pump. Also, allowing only one or two seconds acceleration time will not get any pump up to speed whether loaded or not.

The requirements of Section 4.2.7 (Full voltage starting means) apply with the following modifications.

##### 4.2.8.2 Limits for timed acceleration

For electrical operation of reduced voltage controllers, the duration of the automatically timed period of motor acceleration shall not be greater than 10 seconds from standstill to full speed. After 10 seconds the fire pump controller shall default to full-voltage direct on-line starting/running.

**Note:** The acceleration timer shall be field adjustable up to ten seconds, except for the case of soft start or variable speed which may be fixed.

##### 4.2.8.3 Requirements for starting duty

The following requirements for thermal capacity are design requirements not to be confused with the maximum limits for timed acceleration given in 4.2.8.2 above.

- a. The thermal capacity of starting resistors shall permit one 5 second starting operation in each 80 seconds for a period of not less than 1 hour.
- b. The thermal capacity of a starting reactor or auto-transformer shall permit one 15 second starting operation every 240 seconds for a period of not less than 1 hour. Alternately, a controller over 200 hp (150 kW) shall be permitted to allow three

- 30 second starts separated by 30 second rest intervals in each hour for 2 hours.
- c. When rated in amperes a soft starter shall have a continuous rating of at least 115 percent of the full load current of the motor, or when rated in horsepower at least 100 percent of the horsepower rating of the motor.
  - d. Semiconductor motor controllers shall be rated for utilization category AC-53a with no less than three starts per hour (European Community).
  - e. For star-delta (wye-delta) or part winding start motors, the starting conductors shall be rated as follows:
    1. Part winding: each conductor carries 50 percent of the motor rated operational current;
    2. Star-delta (wye-delta): each conductor carries 58 percent of the motor rated operational current, and transition contactor carries 33 percent.
  - f. Acceleration (starting) contactors shall be rated for the starting currents incurred based on motor LRC (LRA) being 600 percent of motor rated FLC (FLA). Starting (accelerate currents) for reduced inrush starting schemes are typically;
    1. Part Winding: minimum 65 percent of LRC (LRA);
    2. Primary Resistor on 65 percent tap: 65 percent of LRC (LRA);
    3. Primary (or Neutral) Reactor on 65 percent tap: 65 percent of LRC (LRA);
    4. Star-Delta (Wye-Delta): Main Contactor (M1 or 1M); 33 percent;
    5. Autotransformer on 65 percent tap: 46 percent for Start contactor;
    6. Soft start: 65 percent of LRC (LRA)

#### 4.2.8.4 Emergency-run control

A fire pump controller employing a reduced voltage starting means shall also comply with subsection 4.3.1.2 for emergency-run control.

- 4.2.8.5 For controllers rated 600 Volts or less, the operating coil for the main contactor shall be supplied directly at the primary supply circuit voltage.

### 4.2.9 Alarm and signal devices on electric fire pump controllers

#### 4.2.9.1 Devices on the electric fire pump controller

- a. Provisions shall be made to permit reading of all line currents and line-to-line voltages from the exterior of the fire pump controller.
- b. A visible indicator shall monitor the availability of power in all phases at the line terminals of the contactor (motor starting means). When the visible indicator is an incandescent pilot lamp, it shall be accessible for replacement of the bulb (lamp).
- c. Phase reversal on the line side of the contactor (load side of the FPC-short circuit protective devices) shall be indicated by a visible indicator. When the visible indicator is a pilot lamp, it shall be accessible for replacement of the bulb (lamp).
- d. When power is supplied from multiple power supplies (integral transfer switch), monitoring of each power source for phase loss and phase reversal shall be permitted at any point electrically upstream of the line terminals of the contactor, provided all sources are monitored.
- e. A visible indicator shall indicate when the controller is in the “automatic mode” and when the controller is in the “manual mode”. If the controller is not functioning in the automatic mode due to a component or electronic board malfunction (any cause other than controller in manual mode), a visible indicator and audible alarm shall be provided.
- f. Discriminating visual indication shall be provided to indicate that the automatic shutdown feature, (when provided), is disabled or enabled.

- g. A visible indicator for the Emergency Isolating Switch Open on dual source controllers or fire pump transfer switches.
- h. A visible indicator for the Transfer Switch in emergency (alternate source) position on dual source controllers or fire pump transfer switches.
- i. Provisions shall be made to supervise all motor starting contactor coils and provide a visual indicator and audible alarm when an open circuit is detected in any coil. Supervision shall be conducted at a time interval no greater than once every hour.
- j. A visible indicator and audible alarm shall be provided when the controller fails to start from the automatic mode.

4.2.9.1.1 Controllers shall detect the loss of any phase regardless of whether the motor is running or not.

#### 4.2.9.2 Indication devices remote from the controller

Controllers shall be equipped with contacts (open, closed, or both) to operate alarm circuits that indicate the following:

- a. Motor running;
- b. Loss of phase (power not available) on the line side of the motor contactor, if any phase falls below 85 percent of nominal controller voltage;
- c. Phase reversal on the line side of the contactor;
- d. Loss of A.C. power to controller;
- e. Controller connected to alternate source - contacts (open, closed or both), mechanically actuated by the transfer switch mechanism, shall be provided to indicate whenever the alternate source is the source supplying power to the controller.
- f. Drive failure, for electric fire pump controllers with variable speed pressure limiting control;
- g. Bypass mode, for electric fire pump controllers with variable speed pressure limiting control;
- h. Variable speed pressure limiting control over-pressure at 115 percent of set pressure, for electric fire pump controllers with variable speed pressure limiting control.

**Note:** Loss of phase may be between 58 percent and 65 percent for controllers equipped for motor single phase start protection.

4.2.9.2.1 A circuit rated 250 Volts or less with overcurrent protection may be provided in the fire pump controller to power the above alarms. The alarm contacts shall be rated at 125 Volts minimum and have provision for connection to an external circuit.

### 4.3 Priority of manual and automatic operations for electric fire pump controllers

For the purpose of this standard, certain selected functions are assigned to a priority in order to alert the manufacturer and the user that special precautions are required, as follows:

- A-priority: Manual operations that shall have the capability to assume normal automatic operations under prescribed circumstances;
- B-priority: Manual operations that shall have the capacity to be inhibited, or to be subordinated, under prescribed circumstances by automatic operations.

#### 4.3.1 A-priority functions

##### 4.3.1.1 Manual initiated electric control at the controller (Local Start Push Button)

The operation of the manual initiated electric control at the controller shall comply with A-priority by the following means.

A manually operated device shall be provided on the exterior of the controller so that, when the fire pump driver is started manually, its operation is not affected by any automatic starting means. The fire pump driver shall remain in operation until manually stopped. On reduced inrush controllers this means will start the pump in the normal automatic reduced inrush mode. On units equipped with sequential starting, this means shall not be affected (no delay). On controllers equipped with Automatic Stop, this shall not affect this means.

**Note:** The certification agency does not permit Automatic Stop. On controllers equipped with High Zone Start Delay, this delay shall occur on this demand. On controllers equipped with Lockout, which requires acceptance by the AHJ, this means shall not be affected.

##### 4.3.1.2 Emergency-run control at the controller

The emergency-run control can be fulfilled either by a mechanical activation (i.e. mechanical operation of a contactor) or by a redundant electrical switching device (i.e. contactor, manual switch, etc.). The redundant electrical switching device shall be mechanically operable in case of a loss of control power or failure of other control circuit devices.

The electrical characteristics of the switching means shall be verified according to Section 5.10 when operated under the emergency conditions. The emergency-run control shall comply with A-priority by the following means:

- a. An emergency-run device shall be provided for non-automatic start and continuous running operation of the motor;
- b. The emergency-run device shall be latchable in the running position. The latch shall not be automatic but shall be at the option of the operator;
- c. The manual emergency actuator shall be arranged to move in one direction only from “off” to final running position;
- d. The controller shall return automatically to the “off” position if the operator releases the manual emergency actuator in any but the full running latched position.

#### 4.3.2 B-priority functions

##### 4.3.2.1 Manual electric remote control (Remote Start)

Provisions for accommodating remote control stations for causing non-automatic, continuous operation of the pumping unit, independent of the pressure-actuated control switch, shall be provided. Means shall not be provided to stop the pump driver from a remote location. On controllers equipped with Sequential Starting, this means shall not be affected (no delay). On controllers equipped with Automatic Stop, this shall not affect this means.

**Note:** The certification agency does not permit Automatic Stop. On controllers equipped with High Zone Start Delay, this delay shall occur on this demand. On controllers equipped with Lockout, which requires acceptance by the AHJ, this means shall not be affected.

**Note:** There are three levels of pump demands in electric motor driven controllers (Local Momentary, Remote Momentary and Static, such as pressure) and four levels of pump demands in diesel engine driven controllers (Local Momentary, Remote Momentary, Static and test).



#### 4.3.2.2 Wiring and connections

Control circuits shall be designed such that when permissible external control components are connected as intended, breakage, disconnecting, shorting of the wires or loss of power to these circuits may cause continuous running of the fire pump but shall not prevent the controller(s) from starting the fire pump(s) due to causes other than these external circuits.

### 4.4 Functional and performance requirements for electric controllers

#### 4.4.1 General

The functional requirements for the type-tested device shall be verified according to Section 5.

The controller shall be in a fully functional state within 10 seconds upon application of A.C. power.

#### 4.4.2 Ratings and limits

4.4.2.1 Controllers driving electric motor fire pumps shall be rated in terms of the rated operational voltage  $U_e$ , the rated operational current  $I_e$  (or rated operational power), the frequency, the number of phases and the conditional short circuit current in amperes rms symmetrical. The rating shall indicate whether the equipment is for direct or alternating current.

4.4.2.2 Controllers shall operate satisfactorily at any value between 85 percent and 110 percent of their rated operational voltage,  $U_e$ . Where a range is declared, 85 percent shall apply to the lower value and 110 percent to the higher. Controllers shall also operate satisfactorily at 115 percent of full load current.

#### 4.4.3 Short circuit behavior

The fire pump controller shall have the ability to make and break the rated conditional short circuit current. The verification shall be made according to Section 5.7.

#### 4.4.4 Automatic and non-automatic operations

Section 4.3 gives the explanation for assigning a priority to certain designated functions of automatic and non-automatic operations in electric controllers. An automatic controller shall be operable also as a non-automatic controller. A non-automatic controller shall be actuated by manually initiated electrical means and also by manually initiated mechanical means.

#### 4.4.5 Automatic controller – pressure actuated

##### 4.4.5.1 Water pressure control

4.4.5.1.1 A pressure actuated automatic controller shall be provided with a pressure actuated device having independent high and low calibrated adjustments (set points) in the controller circuit. No pressure snubber or restrictive orifice shall be employed within the pressure actuated device, and the pressure sensing element of the pressure actuated device shall meet all design requirements of Section 3.2.10 of this standard.

4.4.5.1.2 Controller actuation by the pressure sensing device at the low adjustment setting shall initiate the pump starting sequence, unless the pump is already in operation.

4.4.5.1.3 The pressure actuated device shall meet the dielectric strength requirements of this standard as defined in Section 5.9.7.

4.4.5.1.4 The pressure sensing element of a pressure actuated device shall have an accuracy

within  $\pm 5$  percent of full scale but not more than 15 psi (105 kPa), and a repeatability of within  $\pm 1$  percent of full scale but not more than 3 psi (20 kPa) throughout its power input range, as defined in Section 5.9.

- 4.4.5.1.5 The pressure sensing element of a pressure actuated device shall be capable of withstanding a surge of pressure of 1.33 times (133 percent) the maximum rated working pressure for 5 minutes with no change in accuracy, repeatability or operational characteristics as defined in Section 5.9.4.
  - 4.4.5.1.6 The pressure sensing element of a pressure actuated device shall be capable of withstanding a surge of pressure of 2 times (200 percent) the maximum rated working pressure, or at least 2000 psi (13 790 kPa) for 5 minutes with no rupture or leakage.
  - 4.4.5.1.7 The pressure sensing element of a pressure actuated device shall be capable of withstanding 6,000 operational cycles from minimum to maximum pressure, at the maximum rated electrical supply input for the device, with no failures or change in accuracy, repeatability or operating characteristics as defined in Section 5.9.6.
  - 4.4.5.1.8 The pressure sensing element of a pressure actuated device shall be capable of withstanding temperature conditioning from ambient temperature to 36 °F (2 °C), and from ambient temperature to 140 °F (60 °C) for 12 hour conditioning periods each, with no change in accuracy, repeatability or operational characteristics as defined in Section 5.9.5.
  - 4.4.5.1.9 A pressure sensing switch, pressure transducer, or pressure transmitter shall meet all requirements specified in this standard for a pressure actuated device.
  - 4.4.5.1.10 A controller that starts the motor before the pressure actuated device, under specified conditions, shall use a drop-out relay to start the motor. Specified conditions refer to controllers with provision to supply special water control equipment such as deluge valves, dry pipe valves, etc. The controller shall be equipped to start the engine upon operation of the fire protection equipment.
- 4.4.5.2 Pressure recorder
- 4.4.5.2.1 A recording device shall be provided to sense and record the pressure in each fire pump controller pressure sensing line at the input to the controller. When provided as part of an electric motor or diesel engine fire pump controller, the recorder shall be capable of operating for at least seven days without resetting or rewinding. The pressure sensing element of the recorder shall meet the requirements in Section 4.4.5 of this standard.
  - 4.4.5.2.2 The pressure recording device for a diesel engine controller shall not be solely dependent upon A.C. electrical power as a power source. Upon loss of A.C. electrical power, the pressure recording device shall be capable of at least 24 hours of additional operation.
  - 4.4.5.2.3 The pressure recording device shall be mounted external to the controller, or in a barriered compartment, or behind a door in a barriered enclosure, or other provisions shall be made to reduce the risk of contact with uninsulated live parts during normal servicing of the pressure recording device.

#### 4.4.5.3 Sequence starting of pumping units (Pumps in Parallel or Pumps in Series)

The controller, for each driver of multiple pump units, shall incorporate a sequential timing device to reduce the likelihood of simultaneous starting of any one pump unit with any other pump unit. This device is not required for the leading pump. If the demand for water exceeds the capacity of the fire pump, subsequent starting of additional fire pumps shall be at intervals between 5 seconds and 10 seconds. When a leading driver does not start, subsequent pumping units shall not be prevented from starting for pumps in parallel. For pumps in series, each pump supplying suction pressure to another pump shall be arranged to start before the pump it supplies.

4.4.5.3.1 Pumps in Parallel (feeding a common header). The lead pump need not have a sequence start delay. Subsequent controllers shall incorporate a delay of 5 to 10 seconds accumulative each, such as 7 seconds on #2, 14 seconds on #3, etc. This delay shall not affect (shall not delay) either local start pushbutton or remote start pushbutton starting. It shall delay pressure loss starting and deluge valve remote starting, if used.

4.4.5.3.2 Pumps in Series. The low zone pump need not have a delay; but, it shall have remote start provisions. Higher zone controller shall have a High Zone delay. The delay shall be 5 to 10 seconds per zone. For a second zone application (pump fed by the low zone pump), the second zone controller shall immediately transmit a pump start (demand) signal to the low zone controller and wait for its high zone timer to time out. Subsequent zone controllers shall do likewise. i.e.: A third zone controller shall transmit a start (demand) signal to the zone two controller which sends likewise to the low zone. Zone two controller waits for 7 second, for example, and zone three controller waits 14 seconds before starting. In three zone installations, the zone two pump also requires remote start provisions; this requirement applies to all higher zone controllers regardless of where in the building they are located. These delays affect pressure loss, deluge, remote momentary and local start pushbutton demands. This is to avoid running a pump dry or to avoid cavitation.

4.4.5.3.3 The controller, for each driver of multiple pump units, shall incorporate an audible alarm when the controller fails to start the driver during a sequential pump start, or when the controller is no longer functioning in automatic mode.

4.4.5.3.4 With pumping units operating singly or in multiple, external control circuits intended to extend outside the fire pump room shall be arranged so that an open- or short circuit of any external circuit shall not reduce the likelihood that the pump or pumps will operate from all other internal or external means. Breakage, disconnecting, shorting of the wires or loss of power to these circuits may cause continuous running of the fire pump but shall not prevent the controller(s) from starting the fire pump(s) due to causes other than these external circuits.

#### 4.4.6 Automatic controller – non-pressure actuated

A non-pressure actuated automatic controller shall use the opening of a remote contact (i.e. smoke detector, fire alarm, carbon monoxide detector) to start the motor. When the controller has a means for connection of a circuit for the remote momentary (remote pushbutton) starting of the fire pump, this means shall be such that the fire pump motor is not capable of being stopped from a remote pushbutton station. No other means of stopping the fire pump motor shall be provided except those on the controller.

#### 4.4.7 Non-automatic controller

4.4.7.1 A non-automatic controller shall be manually actuated by separate electrical and mechanical means. The controller shall be in a fully functional state within 10 seconds upon application of A.C. power.

#### 4.4.7.2 Manual electric control at controller

A manual operated switch shall be provided on the controller so that, when the fire pump motor is started manually, its operation is not affected by the pressure-actuated switch, if provided. The fire pump motor shall remain in operation until manually stopped.

#### 4.4.8 Stopping methods

##### 4.4.8.1 General

Stopping the fire pump driver by the controller shall be accomplished by manual operation of a stop device (i.e. stop pushbutton) on the outside of the controller enclosure. In the case of an automatic controller, manual operation of the device (i.e. pressing and releasing the pushbutton) shall return the controller to the automatic position. If the controller is arranged for automatic shutdown after starting causes (pressure switch, flow switch, deluge valve, remote start, smoke detector, etc.) have returned to normal, a running period timer set for at least 10 minutes running time shall be used. Means shall be provided to disable automatic shutdown. See Section 4.4.8.2 for further clarification.

##### 4.4.8.2 Automatic shutdown after automatic start

When automatic stop is selected at the discretion of the authority having jurisdiction, the controller shall stop the fire pump only after all starting causes have returned to normal and a total operating time of not less than 10 minutes and not more than 30 minutes after initial motor activation has elapsed. Automatic shutdown shall not be permitted where the pump constitutes the sole source of supply of a fire sprinkler or standpipe system or where the authority having jurisdiction has required manual shutdown. Certified controllers shall have a means to disable and lock-out the automatic shutdown feature, and the controller shall have a clear visual indication that the automatic shutdown feature is disabled or enabled. Automatic shutdown shall not affect a Local Start demand, nor a Remote Momentary start demand.

##### 4.4.8.3 Periodic (Weekly) Program Timer

When a controller for an electric motor driven fire pump is arranged to automatically start and run the motor periodically at the discretion of the authority having jurisdiction, that duration shall be no less than 10 minutes and not more than 30 minutes conducted at least once per week. A means to disable the periodic weekly timer must be provided for installations that require a weekly test to be manually initiated and witnessed. A solenoid valve drain on the pressure control line shall be the initiating means. In a non-pressure actuated controller, the periodic (weekly) test may be permitted to be initiated by means other than a solenoid valve. During periodic running, shutdown shall not occur if an actual call to start signal is received by the controller from the water pressure sensing line, manual start device, or a remote start device.

#### 4.4.9 Functional and performance requirements for power transfer switches

##### 4.4.9.1 General

A fire pump power transfer switch is an automatic power transfer switch device that is a critical component. This switch shall comply with either UL 1008 or CSA C22.2 No. 178 and

the requirements of this standard and shall be located in one of the following two places: either in a separate compartment with a barrier within the controller enclosure, or in a separate enclosure attached to the controller. A power transfer switch that operates only in manual mode shall not be used to transfer power between the normal supply and the alternative supply to the fire pump controller. No provisions for remote device(s) shall be installed that will prevent automatic operation of the power transfer switch.

#### 4.4.9.2 Ratings and limits

A fire pump power transfer switch shall be rated in terms of the rated operational voltage,  $U_e$ , the rated operational current,  $I_e$  (or the operational motor power), the frequency, the number of phases and the conditional short circuit current. The combined controller and power transfer switch shall operate satisfactorily at any value between 85 percent and 110 percent of their rated operational voltage,  $U_e$ . Where a range is declared, 85 percent shall apply to the lower value and 110 percent to the higher. The rated operational current of a power transfer switch which is rated in operational motor power, or not, shall be at least 115 percent of the rated full-load motor current, and also be suitable for switching the motor locked rotor current.

A transfer switch shall have a short circuit withstand rating equal to or greater than that of the controller, or be adequate to provide the short circuit rating of the controller, as determined by short circuit testing.

#### 4.4.10 Automatic transfer switching equipment

##### 4.4.10.1 General

The automatic transfer switching equipment shall be electrically operated and mechanically held in position. The automatic transfer switching equipment shall be manually operable.

**Note:** This manual operation need not be capable of external operation.

The automatic transfer switching equipment shall comply with either UL 1008, CSA C22.2 No. 178 or IEC 60947-6-1 class PC, and the operating mechanism shall be such that the load circuit cannot remain permanently switched off from both the normal and the alternative supplies.

Auxiliary contacts (open, closed or both) mechanically operated by the automatic transfer switching equipment shall be provided to indicate the position (normal or alternative) of the power transfer switch.

##### 4.4.10.2 Sensing and signal devices

A fire pump power transfer switch shall be provided with undervoltage sensing devices to monitor all unearthened lines of the normal power supply. When the voltage on any phase at the load terminals of the FPC-short circuit protective devices (i.e. circuit breaker) within the controller falls below 85 percent of the motor rated voltage, the power transfer switch shall automatically initiate transfer to the alternative supply. When the voltage on all phases of the normal power supply returns to within acceptable limits, the fire pump controller may be allowed to transfer to the normal power supply. Phase reversal of the normal power supply shall cause a simulated normal power supply failure upon sensing phase reversal. An externally operable momentary test switch shall be installed on the enclosure to simulate a normal power supply failure. Two indicators shall be provided, visible to the operator, to indicate to which power supply the fire pump controller is connected.

#### 4.4.10.3 Transfer between power supplies

##### 4.4.10.3.1 Transfer delay

A time delay shall be provided to delay transfer from the alternative power supply to the normal power supply until the normal power supply is within acceptable limits. The time delay shall be adjustable between 5 minutes and 30 minutes. The time delay shall be bypassed automatically if the alternative power supply fails.

##### 4.4.10.3.2 Inrush currents

Means shall be provided to reduce the likelihood of higher than normal inrush currents when transferring the fire pump driver from one power supply to the other. This may be accomplished by a momentary transfer to open circuit (program neutral position) or by momentarily disconnecting the power to the motor.

#### 4.4.10.4 Power transfer switch for independent generator alternative supply

##### 4.4.10.4.1 Disconnect/Isolating Switch

A disconnect located within the fire pump power transfer switch enclosure or compartment shall be provided on the line side of the alternate supply input terminals of the power transfer switch. An audible and visual signal shall be provided on the fire pump controller/automatic transfer switch combination to indicate when the disconnect for the alternative supply is open. Auxiliary contacts mechanically operated by the disconnect shall be provided on the power transfer switch enclosure to indicate the position of the disconnect. When this switch is open, it shall inhibit a starting signal to the generator, and shall activate the required alarm signals and devices, both local and remote.

##### 4.4.10.4.2 Short circuit and overcurrent protective devices

When the alternate power supply is provided by an independent generating set whose capacity exceeds 225 percent of the fire pump motor's rated full-load current and that is protected by an overcurrent device at the generator, short circuit and overcurrent protective devices for the alternative power supply to the transfer switch are not required within the power transfer switch enclosure or compartment, see Section 3.2.8.1.4. The locked rotor protective device may be bypassed while the power transfer switch is connected to the alternative supply.

##### 4.4.10.4.3 Sensing devices

Voltage-sensing and frequency-sensing devices shall be provided to monitor at least one phase of the alternative power supply. Transfer to the alternative power supply shall be inhibited until the voltage and frequency are within acceptable limits for the fire pump driver.

**Note:** When the automatic power transfer switch is electrically upstream of the fire pump controller short circuit protective device, the voltage is capable of being sensed at the input of the transfer switch in lieu of at the load terminals of the fire pump controller short circuit protective device.

##### 4.4.10.4.4 Accessory devices

When a power transfer switch is intended to be connected to a generator

alternative supply, it shall be equipped with the following accessory devices:

- a. A device to delay starting of the alternative supply generator to reduce the likelihood of nuisance starting in the event of momentary dips and interruptions of the normal supply;
- b. A circuit loop to the alternative supply generator whereby either the opening or closing of the circuit will start the alternative supply generator;
- c. A means to prevent sending the signal for starting of the alternative supply generator (when commanded by the power transfer switch), when the disconnecter on the alternative supply side of the power transfer switch is open.

#### 4.4.10.5 Power transfer switch for second utility alternative supply

##### 4.4.10.5.1 Disconnector

Section 4.4.10.4.1 applies.

##### 4.4.10.5.2 Switching means

When the alternate power supply is provided by a second utility supply, switching means for the alternative power supply to the transfer switch is required within the power transfer switch enclosure or compartment.

##### 4.4.10.5.3 Short circuit and overcurrent protective devices

When the alternate power supply is provided by a second utility supply, short circuit and locked-rotor protection for the alternative power supply are required.

##### 4.4.10.5.4 Sensing devices

Under-voltage sensing devices shall monitor all phases. Transfer to the alternative power supply shall be inhibited until the voltages are within acceptable limits for the fire pump motor.

## 4.5 High Voltage Fire Pump Controllers (Rated Over 600 Volts)

### 4.5.1 General

A fire pump controller rated over 600V shall comply with the requirements for electric fire pump controllers specified in this standard, and the high voltage equipment shall comply with the requirements specified in UL 347 “High Voltage Industrial Control Equipment” or CSA C22.2 No. 14/TIL D21.

### 4.5.2 Automatic and Non-Automatic Controller

A high voltage fire pump controller shall consist of an automatic and non-automatic controller for starting squirrel-cage motors rated over 600V AC.

### 4.5.3 Meters

Means shall be provided on the exterior of the controller to read all line currents and all line voltages within  $\pm 5$  percent of full scale.

### 4.5.4 Disconnector/Isolation Switch

4.5.4.1 Provisions shall be made to prevent the disconnector/isolation switch from being opened or

closed under load conditions as specified in UL 347 or CSA C22.2 No. 14/TIL D21.

- 4.5.4.2 The disconnecter/isolation switch is not required to be interlocked when a load-break disconnecting means complying with the requirements of UL-347 and IEEE C37.53.1 or CSA C22.2 No. 193, and having suitable fault closing (short circuit) and interrupting current (load break) and continuous current based on the motor load is provided.

#### 4.5.5 Pressure-Actuated Device

A pressure-actuated device shall not be located in a high voltage compartment and shall be located so as to reduce the risk of water leakage from coming in contact with high-voltage components.

#### 4.5.6 Control Circuits

A low-voltage control circuit shall be supplied from the high-voltage source through a step-down control circuit transformer, or transformers, protected by high-voltage fuses rated for the circuit involved. The secondary of the transformer shall be grounded to the enclosure unless all devices connected are rated for the line voltage. The current supply to the transformer(s) shall be interrupted when the isolating switch is in the open position.

#### 4.5.7 Visible Indicators

A visible indicator shall be provided to indicate that power is available. When the visible indicator is a pilot lamp, it shall be accessible for replacement.

#### 4.5.8 Disconnecting Means

- 4.5.8.1 The disconnecting means (contactor and isolation means) shall be in accordance with UL 347 or CSA C22.2 No. 14/TIL D21. If circuit breakers are used as the disconnecting means, they shall meet the requirements of Section 4.2.4, of this standard.

4.5.8.2 When high voltage fuses are used as the disconnecting means, they must be provided in accordance with ANSI/NFPA 20 and UL 347 or CSA C22.2 No. 14/TIL D21 and shall be sized to hold 600 percent of the full-load current rating of the motor for at least 100 seconds. These current-limiting motor circuit fuses shall be mounted in the controller enclosure between the isolation switch and the contactor, and shall interrupt the short-circuit current available at the controller input terminals.

4.5.8.3 When high voltage fuses are used as the disconnecting means, a compartment or rack shall be provided within the controller enclosure for storage of a replacement set of fuses. The replacement set of fuses shall be provided and installed by the controller manufacturer prior to shipment, or provided by the controller manufacturer at the time of system start-up and acceptance.

#### 4.5.9 Emergency Run Mechanical Control at Controller

- 4.5.9.1 The controller shall comply with the requirements for emergency run mechanical control at the controller as described in Section 4.3.1.2.

4.5.9.2 If the mechanical latching described in 4.3.1.2 is able to latch automatically, the locked rotor overcurrent protection for the motor is not required when this mechanical latch is engaged.

#### 4.5.10 Performance

- 4.5.10.1 The controller shall comply with the Locked Rotor Overcurrent Protection specified in Section 4.2.4.4 of this standard, and with the performance requirements of UL 347 or CSA 22.2 No. 14/TIL D21.



4.5.10.2 The emergency run mechanical operation mechanism shall comply with all the performance requirements of UL 347 or CSA 22.2 No. 14/TIL D21, when operated manually, independent of the speed of the manual operation.

4.5.11 Ratings

The controller shall also be rated in accordance with UL 347 or CSA 22.2 No. 14/TIL D21.

4.5.12 Markings

The controller shall comply with the marking requirements specified in UL 347 or CSA 22.2 No. 14/TIL D21, and Section 3.3 of this standard. Exception: The short circuit rating of the controller may be rated and marked in MVA in lieu of symmetrical amperes, where the MVA value is 1.732 times  $U_e$  times the short circuit current rating in kiloAmperes. For controllers tested to 50 kA, the common values are:

<b>2400 V A.C.</b>	<b>4160 V A.C.</b>	<b>7200 V A.C.</b>
<b>200 MVA</b>	<b>400 MVA</b>	<b>600 MVA</b>

**4.6 Fire Pump Motor Characteristics**

4.6.1 General

Motors have a number of characteristics, all of which are important for proper motor application and overall reliability. The following is a list of these characteristics as they relate to fire pump installations. The motor nameplate identifies all the characteristics specific to the motor.

4.6.1.1 Motor-Rated Output Power

Motor-rated output power is a measure of power output of the motor when it is operating at its rated full load. Most motors in North America are rated in horsepower (hp), whereas most motors designed for use on 50 Hz systems, such as those in Europe, are rated in kilowatts (kW). Some motors are dual labeled, showing both ratings. The power output is the primary characteristic for determining the size of the motor.

4.6.1.2 Rated Input Voltage and Frequency

Rated input voltage and frequency indicate the intended operating voltage and operating frequency of the fire pump motor. Because the frequency affects the motor running speed, it also affects the motor’s output power, as the output power is the product of output torque times the running speed (rpm). The frequency also usually affects starting characteristics, such as torque and the locked rotor amps (LRA). Some 60 Hz motors are used at 50 Hz by derating the voltage by the ratio of 50 Hz to 60 Hz or by a derating factor of 83 percent. Because the speed is reduced by the same ratio (factor), the output power is reduced by the same value. Some motors are designed for use on either frequency, whereas others are designed specifically for 50 Hz operation.

4.6.1.3 Rated Motor Speed

Rated motor speed is the speed at which the motor shaft turns under full load and is measured in revolutions per minute (rpm). This speed may also be referred to as the motor’s full load speed. The synchronous speed of the motor is the magnetic field speed and is a function of the line frequency and the number of motor poles. The no load speed and full load speed of the motor is less than the synchronous speed by a few percent. The motor’s ability to operate at full load speed is essential for the pump to deliver rated pressure and flow. Motor speed is less than the motor’s rated speed when the motor is operating above its maximum horsepower

load, and when a three phase motor is running under single-phase conditions.

#### 4.6.1.4 Motor Full-Load Current (FLC)

Motor full-load current (FLC), which is measured in amperes (amps), indicates the current the motor will draw to produce the full rated horsepower when the motor is operating at rated voltage and frequency and with equal line voltages (no line voltage imbalance). The FLC is also expressed as full-load amps (FLA).

#### 4.6.1.5 Motor Torque

Motor torque is the force the motor shaft exerts on the fire pump shaft causing the pump to rotate and is measured in inch-pounds, foot-pounds, or Newton-meters of torque. The value of motor torque changes as the pump initiates operation and as the motor accelerates. The stages or conditions that a pump and motor pass through during normal operation include resting (deenergized), starting (acceleration), and running. A fourth condition associated with abnormal operation includes prolonged stalled or locked rotor condition.

As a motor passes from a resting condition through the starting condition to a running condition, the electrical characteristics, particularly the current draw, associated with the motor vary. As a result, the motor torque in relation to the motor speed also varies as the motor reaches its running condition.

The stalled torque is the initial or zero speed torque, which also occurs during locked rotor condition, and when the motor is energized at full rated voltage. Under this condition, the motor will draw full locked rotor current until the motor begins to accelerate. This torque value is also referred to as the locked rotor torque or the breakaway torque, and is the torque available to break away a seized or stiff pump. This is also the torque available to initiate movement of a pump and motor from their resting condition for an across-the-line start or a manual start.

#### 4.6.1.6 Motor Locked Rotor Starting Code

When the electric circuit to the fire pump controller is closed, initiating operation of the electric motor driven fire pump, a large inrush current can occur to initiate rotation of the motor and pump. Note that this inrush current is less for reduced voltage or reduced current starting methods. When the fire pump impeller and the motor shaft are at rest, a greater amount of torque is necessary to initiate movement of the pump and motor, partly due to their inertia. As a result, a greater amount of current is necessary to start the fire pump motor, much more than is necessary to operate the motor after it has started. These high starting currents normally only occur for a short period of time. These higher currents are also due to the lower energy efficiency of the motor when turning at lower than normal running speeds, because the motor is less efficient in the starting region than the normal running region of operation.

The initial starting current needed to start the motor is normally five to eight times the normal operating current with six times being the accepted value for typical (Design B) motors. This generally accepted value ignores initial offset currents that can occur during the first half line cycle due to circuit inductance. This initial starting current is typically referred to as locked rotor current (LRC) or locked rotor amps (LRA). The current needed to operate the motor, once running under normal conditions, is referred to as full-load current (FLC) or full-load amps (FLA). The LRA is also used to describe the current the motor will draw if its rotor cannot freely rotate due to a locked rotor or stall condition as previously described. The locked rotor condition is not considered a normal operating condition because the higher currents can occur for a much longer period of time than that necessary to start the pump. With reduced inrush starting methods, both the starting current and the starting torque will be reduced when the motor is started in the automatic mode. Manual mechanical starting results in the full voltage starting inrush current.

#### 4.6.1.7 Service Factor

The motor's service factor is a multiplier of an A.C. motor that, when applied to the rated horsepower, indicates a permissible horsepower loading that can be carried at the rated voltage, frequency, and temperature. The service factor indicates the amount by which the motor's rated horsepower can be exceeded on a continuous duty basis when certain operating criteria are met. Therefore, a motor with a service factor of 1.0 cannot be used above its rated horsepower. A motor with a service factor of 1.15 can be used at 115 percent of its horsepower rating if, and only if, all of the required operating conditions are met.

Both NEMA MG-1 and ANSI/NFPA 20 limit the motor's service factor to 1.15 for fire pump motors. This allows the motor to provide up to 115 percent of rated horsepower when running under the following conditions:

- a. At rated voltage and frequency
- b. At a temperature not greater than 104 °F (40 °C) as specified by NEMA MG-1
- c. With a terminal voltage unbalance no greater than 1.0 percent as specified by NEMA MG-1
- d. At an installed altitude no higher than 3300 ft (1000 m) above sea level

The 1.15 service factor limitation prevents motors from being stressed more severely. In addition, the starting torque may not always be adequate if higher service factors were allowed. When operating at the higher range of the service factor, a motor will experience higher heating than if it was used only up to its horsepower rating. When a running motor approaches its service factor, it will draw more current to provide additional horsepower to the fire pump. At 115 percent of rated horsepower, the motor current will be at 115 percent of FLA. This will cause additional heating of the motor windings. Electric fire pump controllers rated 600 Volts or less typically use motors with a 1.15 service factor, and variable speed pressure limiting electric fire pump controllers and high/medium voltage fire pump controllers (rated in excess of 600 Volts) typically operate motors at a 1.0 service factor, but the motor itself is rated with a service factor of 1.15 or higher.

#### 4.6.2 NFPA Service Type Motors

##### 4.6.2.1 Full Service, Three-Phase Motors

With the exception of DC motors, all fire pump A.C. motors must be three-phase motors. This is due to the NEMA definition of Design B motors, stating that they are polyphase and are three phase by virtue of their starting characteristics tables in NEMA MG-1. As a result, all Certified full-service fire pump controllers shall be for three-phase motors. Motors used with variable frequency drives must be additionally rated for "inverter duty" and have a motor service factor of at least 1.15, but the motor shall not be used above the FLA rating at a maximum 1.0 service factor. This provides for the motor having the thermal capacity to handle the extra heating associated with variable speed applications.

##### 4.6.2.2 Single or Three-Phase Motors for Limited Service Controllers

These motors are not acceptable to the certification agency and are not to be used with certified fire pump controllers.

#### 4.6.3 Motor Starting

Modern fire pump installations use any one of ten different motor starting means. They are full voltage (across-the-line also known as direct-on-line) and nine different types of reduced inrush motor starting as indicated in Table 4.6.3. Of the nine reduced inrush starting methods, four require the use of specific types of motors namely, part-winding, wye-delta (closed and open transition), and neutral reactor. The

other four reduced inrush current starting types can use either standard full-voltage starting motors or reduced inrush starting motors because the voltage and/or current reduction takes place within the fire pump controller rather than within the motor.

*Table 4.6.3 Motor and Starting Types*

<b><i>Starting Types</i></b>	<b><i>Motor Type</i></b>
<b>Full Voltage</b>	<b>Standard/Any</b>
<b>Part-Winding</b>	<b>Part-Winding</b>
<b>Wye-Delta - Closed</b>	<b>Delta Run</b>
<b>Wye-Delta - Open</b>	<b>Delta Run</b>
<b>Neutral Reactor</b>	<b>Wye Running</b>
<b>Primary Reactor</b>	<b>Standard/Any</b>
<b>Primary Resistor</b>	<b>Standard/Any</b>
<b>Autotransformer</b>	<b>Standard/Any</b>
<b>Soft Start (SCR)</b>	<b>Standard/Any</b>
<b>Wound Rotor</b>	<b>Wound Rotor</b>

Wound rotor motors are also used for reduced inrush starting, but the cost of wound rotor motors today prevents their use in most installations.

Both the type of motor and the type of controller affect the means of motor starting. In general, three electrical parameters are critical to the successful starting of any fire pump motor:

- a. Starting (locked rotor) voltage drop at the controller
- b. Full load or service factor load voltage drop at the motor
- c. Ability to start the motor without any false tripping of the fire pump breaker (in the fire pump controller) or any upstream overcurrent protection (fuses or circuit breaker) or interruption of the power being supplied to the motor

4.6.3.1 Full Voltage Across-the-Line (ATL) Starting

Full voltage across-the-line (ATL) starting or direct-on-line starting is a means of starting a motor by connecting it directly to the power source in one single step. For this starting method, either standard full-voltage start motors or motors designed for reduced inrush (reduced voltage) starting may be used. This is because both types of reduced inrush motors (part-winding and wye-delta) can be wired for full-voltage starting by wiring them in their “Run” configuration. This running mode wiring applies full voltage and full power to the motor.

Full voltage ATL starting yields the greatest starting torque resulting in 100 percent of the motor’s rated starting torque or locked rotor torque being produced. High starting torque incurs a high starting (inrush) current. Therefore, 100 percent of the motor’s rated LRA, which corresponds to the full 600 percent of the motor’s FLA is incurred.

For ATL starting, the inrush current is the same when the motor is started automatically, via a drop in system pressure, and when it is started by the use of the emergency mechanical operator (the inrush current is the locked rotor current). This is not the case for the reduced inrush starting types. For reduced inrush starting types, the maximum inrush currents occur when these motors are started using the emergency mechanical operator and not when the motors are started automatically.

#### 4.6.3.2 Part-Winding Starting

Certain motors are designed and manufactured as suitable for part-winding starting. A part-winding motor consists of two sets of windings that are both meant to be energized in the motor running condition. As such, these two windings are connected in parallel for motor running. Part-winding motors shall have a 50-50 winding ratio in order to have equal currents in both windings while running at nominal speed. For motor starting only one set of windings are energized. Either set of windings may be energized during the accelerate (starting) period. This is technically “half-winding part-winding start” since only half of the windings are energized during the start interval. This method of starting draws equal running currents through both of the controller’s motor contactors while running. (Contactors in the electric fire pump controller are sized according to the current in each winding.) Another part-winding starting method, known as “double delta, part-winding starting”, draws unequal currents through the two contactors, which results in contactor overload unless specifically designed for such use. As a result, “double delta, part-winding starting” is not used for fire protection service. It is most important to note that not every two-winding, parallel run motor is suitable for part-winding starting. In order to be useful for part winding starting, the motor windings must be distributed in the winding slots in a particular manner.

The part-winding method of starting is known as a two-step starting method. Each of the two sets of motor windings is wired to one of the two motor contactors used in the controller. One contactor connects power to one winding for starting, and the other contactor closes power to the second winding for running. The transition from starting to running is made by energizing the second set of windings while leaving the first (starting) set of winding energized. This makes this starting method a closed transition starting type in which no unusual current spikes or transients occur during the transition from starting to running modes. The motor-starting torque is approximately 48 percent of full voltage and will normally accelerate a fully loaded pump to full speed. Starting currents with one winding energized are typically in the range of 60 to 70 percent of the motor LRA rating.

Finally, part-winding motors (suitable for the service) can be either of the wye-wound (wye-running) or the delta-wound (delta-running) type. Similarly, the motors can be either single or dual voltage types. However, if of dual-voltage type, they can only be used at the lower of the two voltages because the windings must end up in parallel running.

#### 4.6.3.3 Wye-Delta (Star-Delta) Starting

Wye-delta (star-delta) motors are, of necessity, the delta-running type. The only requirement is that both ends of each winding be brought out to the motor’s junction box. Thus, a motor suitable for wye-delta starting must be a six-lead or a twelve-lead motor. A three-lead motor cannot be used for this starting method.

During installation, the motor windings are connected in a specific manner to two motor contactors in the fire pump controller. The controller will have either one or two additional contactors that are wired internally in the controller. This internal wiring is completed at the factory and not in the field. For starting, the controller connects one set of leads together to form the “wye”, or “start” point. The other end of the windings is connected by one of the motor contactors to the line voltage. The result is that the windings are energized at only 58 percent ( $1/\sqrt{3}$ ) of their rated voltage. Specifically, a 208-volt motor will have 120 volts applied to the windings for starting, and a 460-volt motor will have 266 volts applied. The line starting currents are reduced to one-third of LRA since each line now “sees” only one end of one winding rather than two windings as when in delta. The starting torque is similarly reduced to one-third of full voltage starting (57.7 percent squared).

When the accelerate (starting) period ends, the controller reconnects the windings from the wye configuration to the delta configuration. This, then, applies full-rated line voltage to each

motor winding with two windings connected to each line phase. Controllers that make this reconnection in a single step are of the so-called open transition wye delta starting type. These are three-step starters: Specifically, (1) start in wye, then (2) open the wye point, and (3) finally, reconnect in delta. Controllers that make the transition from wye to delta in two steps, rather than one, are known as closed transition wye-delta start controllers. They are four step starters because they (1) start in wye, (2) connect transition resistors to the source (mains) voltage, (3) connect the motor to the source in delta through the resistors, and finally (4) bypass the resistors to leave the motor connected directly to the source in delta.

The downside of the wye-delta starting method is the very low starting torque (33 percent of full-voltage starting torque). This is not enough to fully accelerate a fully loaded pump, as is also the case with many pumps even at churn (shut-off). The result is that full-voltage starting currents are incurred after the end of the accelerate period when full voltage and full power are applied to the motor. Nonetheless, these high inrush currents can cause any number of problems, particularly when the fire pump power is supplied by a standby generator set or by a dedicated transformer, which can incur very large voltage drops at full voltage inrush starting currents. A second problem with this starting method can occur with open transition wye-delta starting unless the controller incorporates means to control the high-spike transition current that can occur at the instant when full voltage is applied to the motor. This is due to an out of phase condition.

#### 4.6.3.4 Primary Resistor or Primary Reactor

Both primary resistor and primary reactor start controllers insert an impedance in series with the motor for starting to reduce the motor voltage and its starting current. The impedance is either resistance or inductance (reactance). At the end of the starting interval, the impedance, caused by the resistors or the reactor windings, is bypassed, (short-circuited), by the motor-run contactor to apply full voltage to the motor for normal running. Because the impedance is shorted for running, these types of controllers are of the two-step starting type and the closed transition type. The primary resistor or primary reactor starting method is also suitable for use with medium-voltage motors. At the typical tap setting of 65 percent, the motor torque is 42 percent of full voltage and will normally accelerate a fully loaded pump to full speed.

#### 4.6.3.5 Soft Start

Soft start starting is similar to primary resistor and primary reactor starting in that the voltage to the motor is reduced by a device connected in series with the motor. In the case of soft start controllers, a solid-state soft start motor starter unit is used to accelerate the motor by reducing and controlling the voltage fed to the motor. This is done by gradually ramping up the motor voltage from a starting point, typically about 40 percent of full voltage up to full line rated voltage. The soft start unit controls the voltage by the use of silicon-controlled rectifiers (SCRs). The conduction angle is varied to affect the desired voltage control. Thus, the controller delivers a variable starting voltage to the motor that results in initially reduced starting current. The motor starting current gradually reaches full voltage starting current levels (near LRA) depending on the load on the motor and several other factors. After the motor is accelerated during the starting phase, the motor contactor in the controller short circuits the soft start unit, the SCRs, to apply full line (mains) voltage to the motor.

Some controllers have a second contactor to isolate the soft start unit from line voltage transients when the pump is in the standby mode. These controllers are of the two-step starting type and are also of the closed transition type. These types of starters are often used for hydraulic reasons such as to reduce the surge of water into the system on pump starting or to reduce water hammer on pump shutdown, instead of or in addition to the need for reduced inrush current starting requirements.

#### 4.6.3.6 Autotransformer

Autotransformer start controllers contain a motor-starting autotransformer used to reduce the voltage to the motor during the starting phase. This starting means is also suitable for medium-voltage motors. During starting, the motor voltage is reduced according to the autotransformer voltage taps used. Typically, the 65 percent voltage tap is used, which provides 65 percent of the motor's rated voltage to the motor for starting. At this tap setting, the motor torque is 42 percent of full voltage and will normally accelerate a pump from its resting condition up to full speed, even if the pump is fully loaded.

At the end of the starting phase when the motor is accelerated, the controller disconnects, that is, opens the autotransformer wye connection, then short-circuits the top portion of the transformer windings to apply full voltage to the motor. This sequence makes the autotransformer starting method a three-step starting means. During the second step, when the autotransformer wye point is an open circuit, the autotransformer acts as a saturable reactor like the foregoing primary reactor starting method. During the last step when the top portion of the transformer is short-circuited, the resulting impedance is similar to that for the primary reactor starting as discussed previously. As a result, the motor is never disconnected, making this starting method the closed transition type.

**Note:** Primary resistor, primary reactor, autotransformer, and soft start can be used with any suitable fire pump motor as permitted by ANSI/NFPA 20. Three lead motors are suitable and may be either wye or delta running types, because the voltage or current reduction occurs within the controller, and as a result, only one "motor" contactor is used and connected to the motor. Nonetheless, controllers for these four starting types will have one or two additional contactors that are internally connected.

#### 4.6.3.7 Neutral Reactor

Primary reactor and autotransformer are suitable for use with high/medium voltage motors, (rated over 600 V AC). For voltages over 5000 V AC, a variation of the primary reactor starting means is used in conjunction with wye-running motors. This starting means works basically the same as the primary reactor, with the exception that the reactor coils are inserted in series with the wye end of the motor windings rather than at the line voltage end. The current reduction is exactly the same for a given voltage tap, typically 65 percent of the full line rated voltage with a resulting torque of about 42 percent of full rated torque. At the end of the starting phase when the motor has been accelerated, the controller "Run" contactor short-circuits the reactor coils, allowing full voltage across the motor windings for full-voltage running. The reason for using neutral or low-side reactors rather than primary or high-side reactors for line voltage above 5000 V A.C. is that the reactor coils do not operate at the full line voltage, but rather at a lower voltage level. This typically reduces their cost, since a lower level of insulation can be used in the construction of the reactor.

### 4.7 Diesel engine fire pump controllers

#### 4.7.1 Priority of operations for diesel engine fire pump controllers

##### 4.7.1.1 General

A-priority operations shall have the capability to take over normal operations under prescribed circumstances. B-priority operations shall have the capacity to be inhibited, or to be subordinated, under prescribed circumstances. The general arrangement shall be as shown in Figure B-6.

#### 4.7.1.2 Emergency control

Emergency control is an A-priority operation. Automatic control circuits, the failure of which could prevent engine starting and running, shall be completely bypassed during manual start and run.

#### 4.7.2 Standard equipment

##### 4.7.2.1 Classification of equipment

A diesel engine drive controller shall be capable of both automatic and non-automatic operation. Controllers driving diesel engine fire pumps shall be rated in battery voltage and control power voltage.

##### 4.7.2.2 Locked enclosure

All switches required to keep the controller in the automatic position shall be secured by one of the following methods:

- a. Located within lockable cabinet enclosures and shall be accessible by opening the enclosure such as with a key or similar device that is available within a break glass box attached to the controller enclosure, or by opening the enclosure via breakable glass panels or breakable transparent cover. The switches shall be visible through the breakable transparent cover or breakable glass panels;
- b. Located within lockable cabinet enclosures and shall only be accessible by opening the enclosure through some type of tamper resistant mechanism that meets the intent of this standard at the discretion of the certification agency. The switches shall be visible through the tamper resistant mechanism;
- c. Located on the exterior door of the enclosure and shall only be operable by the use of a key or similar device that is available within a break glass box or tamper resistant mechanism attached to the controller enclosure.

##### 4.7.2.3 Alarm and signal devices on diesel engine fire pump controllers

All visible indicators shall be plainly visible to the operator. Visible indication shall be provided to indicate that the controller is in the automatic position. If the visible indicator is an incandescent pilot lamp, it shall be accessible for replacement of the bulb (lamp).

4.7.2.3.1 Discriminating visible indication (separate visible indicators) and a common audible alarm capable of being heard while the engine is running shall be provided. All alarms shall be operable in all positions of the main switch except "off", and they shall indicate the following conditions:

- a. Low fuel level, alarm at two-thirds tank capacity;
- b. Low engine oil pressure. Means shall be provided on the controller for testing the position of the contacts of the engine oil pressure switch without causing premature operation of the alarm;
- c. High engine jacket coolant temperature;
- d. Failure of engine to start automatically;
- e. Engine overspeed shutdown;
- f. Battery failure, missing or disconnected battery. Each controller shall be provided with a separate visible indicator for each battery (i.e. Battery #1 and Battery #2).

**Note:** For diesel driven fire pump controllers with built-in battery charger (dual charger), the required battery failure alarms for battery number 1 and battery number 2, and the required battery charger failure alarm shall be



indicated through the engine failure contacts for remote trouble even when A.C. or D.C. power does not exist. The presence of one or more of these three alarms shall not inhibit the operation of the engine failure contacts for remote “trouble” on the controller or engine.

- g. Loss of D.C. power to controller.  
**Note:** The intent of this alarm is for situations where both batteries have been disconnected from the controller, or where the controller is not operating in automatic mode due to a relay component or electronic board failure. This condition assumes that A.C. power is still available to the controller (i.e. battery chargers).
- h. Low air or hydraulic pressure. Where air or hydraulic starting is provided, each pressure tank shall provide to the controller separate visible indicators to indicate low pressure.
- i. System overpressure, for engines equipped with pressure limiting controls, to actuate at 115 percent of set pressure.
- j. Electronic/engine control module (ECM) selector switch in alternate position (for diesel engines with ECM only).
- k. Electronic/engine control module (ECM) warning (for diesel engines with ECM only).
- l. Electronic/engine control module (ECM) failure (for diesel engines with ECM only).
- m. Fuel injection malfunction (for diesel engines with ECM only).
- n. Loss of signal, power, or malfunction of speed switch/sensor on diesel engine. Fuel and cooling water solenoids shall remain open during this alarm for a minimum period of one hour. See Section 2.1.5 item 3 for allowable exceptions.  
**Note:** Normally, if the controller no longer senses that the engine driver is running due to a faulty speed switch, the controller will initiate the crank sequence to restart the engine. After 6 attempts are made, the controller will be locked-out, fuel and cooling water solenoid valves are closed, and an alarm is sent. Is this occurs during a fire condition, there will be a loss of water to the fire suppression system.
- o. Electrical power lost to diesel engine starter unit.  
**Note:** This visual indication and audible alarm is required for all fire pump controllers installed in Europe
- p. Loss of electrical continuity to engine starting contactors. Provisions shall be made to supervise all engine starting contactor coils to detect an open circuit in any coil. Supervision shall be conducted at a time interval no greater than once every hour.
- q. Low engine temperature.
- r. High cooling water temperature.
- s. Clogged raw water coolant loop strainer.

The above audible alarms shall be muted by the operation of the main switch to the “off” position, with the exception of the low fuel level alarm, (“a”), ECM selector switch in alternate position, (“j”), ECM warning (“k”) and ECM failure (“l”). Alarm conditions “a”, “j”, “k” and “l” shall be muted by a separate alarm silence switch when the main control switch is in the “Auto” position, but visible indication shall remain for alarm conditions “a”, “j”, “k” and “l”. No other audible alarm silencing switch, other than the controller main switch, shall be provided for alarms “b”, “c”, “d”, “e”, “f”, “g”, “h”, “i”, “m”, “n”, “o”, “p”, “q”, “r” and “s” covered by Section 4.7.2.3.1, and it shall not be possible to silence the audible alarm corresponding to these alarm conditions when the condition(s) that caused the alarm are present. If other optional audible alarms are provided, a silence switch may be provided to mute

only the optional alarms (see Section 4.7.2.3.3).

- 4.7.2.3.2 Discriminating visual indication shall be provided to indicate the following conditions (common audible alarm not required):
- Controller in automatic position;
  - Controller in manual position;
  - Automatic shutdown feature (when provided) is disabled or enabled;
  - Battery charger failure. Each controller shall be provided with a separate visible indicator for battery charger failure.
- Note:** Manual isolation of battery chargers constitutes a battery charger failure and must be visibly alarmed.
- 4.7.2.3.3 A separate audible alarm silencing switch shall be provided for any alarms not addressed by this section, such as pump house trouble alarms required by the AHJ (see below). The silencing switch must be located adjacent to the visual indicator and be clearly marked as such.
- Pump room temperature low (Freeze Alarm)
  - Fire water reservoir low
  - Fire water reservoir empty
  - Flow meter on (Open)
  - Relief valve open (Flowing)
  - Engine temperature low
  - High fuel level (Fuel spill alert)
  - Fuel spill

4.7.2.4 Alarm contacts for remote indication

Controllers shall be equipped with contacts (open or closed) to provide for remote indication of the following alarms:

- Engine running (separate signal);
- The controller main switch has been turned to “off” or “manual” position (separate signal);
- Abnormal conditions (such as engine overspeed, high coolant temperature, low oil pressure, failure to start, engine failure) on the controller or engine (separate or common signals).
- Power failure. The polarity needs to be reversed on this alarm to allow a signal to be sent when there is a total loss of power to the diesel controller due to; loss of A.C. power, both batteries disconnected (loss of D.C. power) or both circuit breakers inside the controller enclosure have tripped or been opened.
- Pump house trouble, if required by the AHJ.

4.7.2.5 Enclosure Mounting

- The enclosure structure or panel shall be securely mounted in, as a minimum, a NEMA Type 2 drip-proof enclosure, or a minimum IEC Code of IP31.
- Where the equipment is located outside or special environments exist, suitably rated enclosures shall be used, in accordance with NEMA 250 - *Enclosures for Electrical Equipment (1000 Volts Maximum)*, UL 50 - *Standard for Enclosures for Electrical Equipment* or IEC 60529, *Degrees of Protection Provided by Enclosures*.

4.7.2.6 Field Wiring Terminals

- Field wiring terminals shall comply with Section 4.1.7 of this standard, and shall be suitable for the field wiring of stranded type conductors.
- Factory installed field wiring terminals and overcurrent protection shall be provided where diesel engine fire pump controllers supply essential and necessary A.C. and/or

D.C. power to operate pump room dampers and engine oil heaters and other associated required engine equipment. A separate D.C. power circuit shall be provided for required engine equipment with a D.C. load that exceeds 0.5 amps on a continual basis.

- c. No undervoltage, phase loss, frequency sensitive, or other sensor(s) shall be installed that automatically or manually prohibits electrical actuation of the engine starting contactor.

#### 4.7.2.7 External Circuits

With pumping units operating singly, or in multiple, the control circuits entering or leaving the fire pump controller and intended to extend outside the fire pump control room shall be so arranged as to prevent failure to start due to fault. Breakage, disconnecting, shorting of the wires, or loss of power to these circuits may cause continuous running of the fire pump, but shall not prevent the controller(s) from starting the fire pump(s) due to causes other than these external circuits.

### 4.7.3 Starting and control

#### 4.7.3.1 Normal control

An automatic controller shall also be operable as a non-automatic controller. For a manual electric control at controller, there shall be a manually operated switch on the controller panel. This switch shall be so arranged that operation of the engine, when manually started, is not affected by the pressure-actuated switch. The arrangement shall also be such that the unit remains in operation until manually shutdown. The primary power supply for a diesel engine drive controller shall be the engine batteries. Wiring elements of the controller shall be designed on a continuous-duty basis.

#### 4.7.3.2 Sequence starting of pumping units (Pumps in Parallel or Pumps in Series)

Same requirements as detailed in Section 4.4.5.3.

#### 4.7.3.3 Manual electric remote control

Provisions for accommodating remote control stations for causing non-automatic, continuous operation of the pumping unit, independent of the pressure-actuated control switch, shall be provided. Means shall not be provided to stop the pump driver from a remote location.

In addition, when remote control is used, the following requirements apply:

- a. The controller shall be equipped to start the engine upon operation of remote push-button stations;
- b. When the controller is arranged for automatic shutdown, remote stations shall not be capable of stopping the unit except through the established operation of the running period timer.

### 4.7.4 Batteries and battery chargers

General: Two means for recharging storage batteries shall be provided for each fire pump unit. One method shall be the generator or alternator furnished with the diesel engine, and the other method shall be two automatically controlled chargers taking power from an alternating current power source.

#### 4.7.4.1 Battery chargers

Battery chargers shall comply with the following:

- a. The battery chargers shall consist of two independent battery charging circuits, and be specifically listed for fire pump service;

- b. The rectifier shall be a semiconductor type;
- c. The charger for a battery unit shall be a type that automatically reduces the charging rate to a rate suitable for the battery with which the charger is intended to be used;  
**Note:** Lead acid battery chargers will reduce charging current to less than 500 mA automatically after the battery(s) reaches a fully charged condition.
- d. The battery charger at its rated voltage shall be capable of delivering energy into a fully discharged battery in such a manner that it will not damage the battery. It shall restore to the battery 100 percent of the battery's ampere-hour or reserve capacity rating within 24 hours;
- e. The charger shall be marked with the ampere-hour or reserve capacity rating of the largest capacity battery unit that it can recharge;
- f. An ammeter with a scale not exceeding 250 percent of rated charging current and an accuracy of  $\pm 5$  percent of full scale shall be provided for each battery bank to indicate the charging current;
- g. The charger shall be designed so that it will not be damaged or open fuses during the cranking cycle of the engine when operated by an automatic or manual controller;
- h. The charger shall automatically charge at the maximum rate whenever required by the state of charge of the battery unit;
- i. The total discharge current from two fully charged batteries with the battery chargers disconnected from the A.C. power source shall not exceed 50 mA.
- j. The battery charger shall be arranged as to detect the loss of current flow on the load terminals, detect a damaged battery, and detect a missing or disconnected battery.
- k. The battery charger must be of sufficient robust electronic and material construction to operate in the same environment (rated temperature range) as the fire pump controller [i.e. 39 °F to 104 °F (4 °C to 40 °C)].
- l. Battery chargers shall not be used as power supplies to power accessories outside of the controller that exceed a load of 0.5 amps on a continual basis.

#### 4.7.4.2 Voltage measurement

A voltmeter with a scale not exceeding 250 percent of rated battery voltage and an accuracy of  $\pm 5$  percent of full scale shall be provided for each battery bank to indicate the voltage during cranking.

#### 4.7.4.3 Batteries

- a. Each engine will be provided with two storage battery units.
- b. Fully charged engine batteries shall be able to maintain engine starting capability for a period of no less than 96 hours from the combined charge of the two storage battery units, in the absence of A.C. (mains) power.
- c. The total current draw from the controller, diesel engine panel and electronic control module (when provided) in the standby or ready mode shall be less than 0.5 Amps.  
**Note:** The battery chargers need to go into "float" mode to prolong the life of the batteries. Excessive current draw from the controller, diesel engine panel and electronic control module will require the battery chargers to operate in "charge" mode for extended periods that will reduce the overall life of the batteries.
- d. At 40 °F (4.5 °C) each battery unit shall have twice the capacity sufficient to maintain the cranking speed recommended by the engine manufacturer through a 3 minute attempt-to-start cycle, which is six consecutive cycles of 15 seconds of cranking and 15 seconds of rest.
- e. Storage batteries shall be rack supported above the floor, secured against displacement, and located where they will not be subject to excessive temperature,

vibration, mechanical injury, or flooding with water. Current carrying parts shall not be less than 12 in. (305 mm) above the floor level.

- f. Storage batteries shall be readily accessible for servicing.
- g. Lead-acid batteries shall be furnished in a dry charge condition with electrolyte liquid in a separate container. Electrolyte shall be added at the time the engine is put in service and the battery is given a conditioning charge.
- h. Nickel-cadmium batteries, or other kinds of batteries, shall be permitted to be installed in lieu of lead-acid batteries provided they meet the engine manufacturer's requirements.

#### **4.8 Automatic operation of a diesel engine drive controller – pressure actuated**

- 4.8.1 Water pressure control requirements for a diesel engine drive controller are per Section 4.4.5.1 of this standard.
- 4.8.2 Requirements for the pressure recorder for a diesel engine drive controller are per Section 4.4.5.2 of this standard.
- 4.8.3 Controllers with provision to supply special water control equipment (deluge valves, dry pipe valves, etc) shall be permitted to start the engine before the pressure-actuated switch(es) would do so. The controller shall be equipped to start the engine upon operation of the fire protection equipment. The starting sequence of the controller shall be initiated by the opening of the control circuit loop containing the remote equipment.

#### **4.9 Automatic operation of a diesel engine drive controller – non-pressure actuated**

Automatic starting of a non-pressure actuated automatic controller shall be accomplished by the opening of a contact in the external sensing device (i.e. smoke detector, fire alarm, carbon monoxide detector). When the controller provides a means for the remote starting of the fire pump, this means shall comply with the requirements of Section 4.7.3.3.

#### **4.10 Method of starting of a diesel engine drive controller, pressure actuated and non-pressure actuated**

The power supplies for starting the engine shall be two separate battery units. The controller shall be arranged so that manual and automatic starting of the engine can be accomplished with either battery unit. The controller shall alternate between the first battery unit and the second battery unit during successive attempts to start the engine. The changeover shall be made automatically, except for manual start. The "starting sequence" shall be a series of six "on-load" to "off-load" cycles set for equal periods of 15 second durations. Other starting sequences can be accepted as alternatives and shall be subject to agreement between manufacturer, authority having jurisdiction and the certification agency. If the starting sequence has expired, and if the controller has not received a signal that the engine is running, and that the engine speed switch is not disabled, then the controller shall stop all further starting and operate a visible indicator and audible alarm on the controller and de-activate the fuel and water solenoids. If one battery unit is not operative or is missing, then the controller shall lock-in to the remaining battery unit during the starting sequence.

#### **4.11 Methods of stopping diesel engine fire pump controllers**

##### **4.11.1 Manual stopping**

Manual stopping shall be accomplished by either one of the following methods:

- a. Operation of the main control (selector) switch located inside the controller and visible through a breakable glass panel/breakable transparent cover, or located on the outside of the controller cabinet door and secured by a tamper resistant device, and;

- b. Operation of a stop pushbutton located on the outside of the controller enclosure.

Operation of the stop pushbutton shall cause the engine to shutdown only when all starting causes have been returned to normal. The controller shall then return to the full automatic position. Operation of the main control (selector) switch shall shut the engine down unconditionally. This is considered an emergency stop operation.

- Note 1:** The 30-minutes minimum run time for diesel engines is to drive off any condensation in the oil pan, and to prevent build-ups of condensation in the exhaust system (wet stacking).
- Note 2:** When the controller has a means for connection of a circuit for the remote starting of the fire pump, this means shall be such that the fire pump engine is not capable of being stopped from the remote station.

#### 4.11.2 Automatic shutdown after automatic start

4.11.2.1 When the controller is set for automatic engine stopping at the discretion of the authority having jurisdiction, the controller shall stop the engine only after all starting causes have returned to normal and a total of 30 minute minimum run time has elapsed. Automatic shutdown shall not be permitted where the pump constitutes the sole source of supply of a fire sprinkler or standpipe system, or where the authority having jurisdiction has required manual shutdown. Certified controllers shall have a means to disable and lock-out the automatic shutdown feature, and the controller shall have a clear visual indication that the automatic shutdown feature is disabled or enabled. Automatic shutdown shall not affect a Local Start demand, nor a Remote momentary start demand.

4.11.2.2 When the engine overspeed device operates, the controller shall remove power from the engine running devices, prevent cranking and energize the overspeed alarm until manually reset. Resetting of the overspeed circuit shall be required at the engine and by resetting the controller main switch to the "off" position. The controller shall not be capable of being reset until the engine overspeed stopping device is manually reset.

4.11.2.3 The engine shall not stop automatically on high water temperature or low oil pressure when any automatic starting or running cause exists. When no other starting or running cause exists during engine test, automatic stopping shall be permitted on high water temperature or low oil pressure. If after shutdown a starting cause occurs, the controller shall restart the engine and override the high water temperature and low oil shutdowns for the remainder of the test period.

### 4.12 Field Testing of Diesel Engine Fire Pump Controllers

#### 4.12.1 Manual testing of automatic operation

The controller shall be arranged to manually initiate automatic starting of the engine by opening the solenoid valve drain. In a non-pressure actuated controller, the start shall be initiated by means other than a solenoid valve.

#### 4.12.2 Periodic (weekly) program timer

The equipment in the controller shall be arranged to automatically start and run the engine periodically (at least once per week) for a duration agreed by the manufacturer and the user, but not less than 30 minutes. Means shall be provided to disable the automatic periodic test timer to require manual operation for periodic testing. A solenoid valve drain on the pressure control line shall be the initiating means. In a non-pressure actuated controller, the periodic weekly test may be permitted to be initiated by means other than a solenoid valve. In the event that an actual call to start signal occurs during the weekly test, the periodic program timer shall immediately default to full automatic run operation with no interruption in the engine driver speed. Manual operation of the controller shall always override the

periodic program timer.

#### 4.13 Additional Functional and Performance Requirements for Positive Displacement Additive/Foam Pump Controllers

##### 4.13.1 Automatic starting

Automatic starting shall be accomplished by the opening of a remote, normally open or normally closed, contact. The pressure-actuated device described in Section 4.4.5.1 is not required. When a pressure actuated device is provided, the controller shall comply with Section 4.4.5.1 of this standard.

##### 4.13.2 Method of stopping

Manual stopping shall be the only method of stopping. Automatic shutdown shall not be permitted.

##### 4.13.3 Lockout feature

When required for duty standby applications (multi-pump installation), the controller shall contain a lockout feature to stop the additive pump motor. This lockout shall be indicated by a visible indicator and provisions provided for annunciation at a remote location.

##### 4.13.4 Dump Valves

###### 4.13.4.1 Diesel Engine Drive Control Automatic Operation

When a diesel driver is used in conjunction with a positive displacement pump having an electrically operated dump valve, the controller shall provide a means to activate and then close the dump valve after successful engine start has been attained.

The means shall consist of circuitry and terminals for connecting the dump valve solenoid coil.

The dump valve solenoid shall be energized by engine battery power.

The controller circuitry shall cause the dump valve to open to unload the pump, prior to or concurrent with the first engine cranking cycle.

The controller circuitry shall allow the engine to reach full speed and full power capability before closing the dump valve.

###### 4.13.4.2 Electric Motor Drive Control Automatic Operation

When an electric motor driver is used in conjunction with a positive displacement pump having an electrically operated dump valve, the controller shall provide a means to activate and then close the dump valve after the motor has full voltage.

The means shall consist of circuitry and terminals for connecting the dump valve solenoid coil.

The controller shall provide suitable voltage for the dump valve solenoid. Said power shall not exceed 240 V A.C.

The controller circuitry shall cause the dump valve to open to unload the pump, prior to or concurrent with motor power being applied.

The controller circuitry shall allow the motor to reach full speed and full power capability before closing the dump valve.

#### 4.13.4.3 Manual Operation

Means shall be provided at the controller to ensure dump valve operation during manual start.

### 4.14 Variable Speed Electric Motor Driven Fire Pump Controllers

For Electric Drive Variable Speed Fire Pump Controllers with or without built in Power Transfer Switches, the following additional requirements apply. Note that the text uses the acronym VSD (Variable Speed Drive) to refer to the fire pump controller components and variable speed path items, and uses the term VFD (Variable Frequency Drive) to refer to the motor drive unit itself.

#### 4.14.1 General Controller Equipment Requirements

##### 4.14.1.1 Compliance

Controllers equipped with variable speed pressure limiting control shall comply with all of the requirements of this section as well as all requirements for electric motor driven fire pump controllers in this standard.

- a. Each variable speed electric motor driven fire pump controller (VSEFPC) shall consist of, as a minimum, a full service and complete fire pump controller which constitutes the full speed "Bypass" power path and control, and;
- b. A variable speed power path and control which complies with the requirements of this section (see Figure B-9).

4.14.1.2 Controllers with variable speed pressure limiting control shall be specifically Certified for variable speed fire pump application.

4.14.1.3 Power Capability. Both the Bypass path and the VSD path shall have a horsepower rating at least equal to the motor horsepower or, where rated in amperes, shall have an ampere rating not less than the motor full-load current. The VSD path shall comprise a Variable Frequency Drive (VFD) unit and other components as listed below.

4.14.1.4 Pre-shipment. All Variable Speed Controllers shall be factory assembled, programmed and tested as a complete unit prior to shipment.

- a. The factory shall retain a copy of all parameters and programs required for proper pump and controller operation.
- b. The factory shall test the controller on a minimum 15 hp (10 kw) motor for proper operation of the various modes of operation.
- c. All VFD parameters (including set pressures) required for proper operation shall be clearly and permanently marked on the controller interior. An additional mounting plate or permanent label shall be provided for the VSD pressure set points when field adjustments are made to the original pressure settings. This field plate/label shall be inscribed with permanent markings and placed over the original factory label.
- d. The factory shall ship the variable speed controller as one unit, unless special provisions are made, between the controller manufacturer and the end user, for the controller manufacturer to ship the VSEFPC unit in no more than two parts (FPC and VSD) and then reassemble the VSEFPC unit in the field. Field reassembly of the VSEFPC must be performed by certified personnel from the controller manufacturer's facility. Field agents outside the direct employment of the controller manufacturer are not allowed. The VSEFPC must be tested as one unit prior to shipment.



#### 4.14.2 Environmental Requirements

##### 4.14.2.1 Temperature

The controller shall be marked with the maximum ambient temperature rating.

- a. Temperature rating shall not be less than +104 °F (+40 °C).
- b. The entire VSEFPC unit shall be evaluated for suitability at the rated temperature.
- c. All components shall be suitable for the internal temperature achieved when the unit is operating at full load and at the rated external ambient temperature. This includes, among others:
  1. The VFD variable speed drive
  2. The Line Reactor
  3. The D.C. Link Reactor (Choke), when used
  4. The Motor Reactor, when used
  5. The Motor Filter (dV/dT Filter), as used per Section 4.14.3.2.4.
- d. Conformity shall be determined by system testing and by listed component ratings including, as a minimum:
  1. Component temperature ratings
  2. The controller internal temperature rise above the external ambient temperature
  3. Cooling equipment ratings
- e. The controller manufacturer shall determine the maximum heat dissipation (heat output or heat rejection) from the controller, including the VFD and all power path components, including all reactors and filters, and any cooling means that creates significant heat.
- f. The manufacturer shall mark the controller with the heat dissipation in either BTU or Watts, and;
- g. The manufacturer shall make the controller heat dissipation information available to the pump room or pump house designer.

**Note:** This is to avoid pump room or pump house temperatures that exceed +140 °F (+40 °C) when the motor is running at full load and when the conditions are most likely to cause the highest temperature in the proximity of the fire pump controller. Said designer must also take into account the heat rejection of the fire pump motor when running at full load and any and all other heat producing or heat rejecting equipment in the local environment.

##### 4.14.2.2 Protection from water, moisture, dust and dirt

- a. The entire unit shall be protected from the ingress of water, moisture, dust and dirt.
- b. When installed indoors and in sprinklered pump rooms, the minimum level of protection shall be to protect the equipment inside the enclosure against ingress of solid foreign objects (falling dirt and circulating dust, lint, fibers, and flyings), and against ingress of water (dripping and splashing), and shall meet as a minimum NEMA Type 12 or equivalent IEC IP code (See Appendix E, Table E.2 for NEMA Type/IEC IP conversion).
- c. When installed outdoors or in pump houses, the equipment shall meet one of the following NEMA ratings or equivalent IEC IP code:
  1. NEMA Type 3
  2. NEMA Type 4 or better

##### 4.14.2.3 Pollution Degree

The entire enclosure shall meet the Degree of Pollution requirements specified in ANSI/UL 508C, *Standard for Safety for Power Conversion Equipment* and IEC 60947-1, *Low-Voltage Switchgear and Controlgear - Part 1: General rules*, and any special pollution requirements

as specified by the authority having jurisdiction at the installation. The minimum requirement for fire pump controllers is pollution degree 3 environmental conditions.

**Note:** All presently manufactured VFD's employ fine line printed circuit board layout rules, surface mount devices and millimeter spacing on many components. Protection against dust, dirt and moisture is required for these devices.

#### 4.14.2.4 Corrosive Environments

- a. The controller shall be protected from dripping and spraying water that may contain corrosive particles.
- b. The controller shall be protection from any anticipated gaseous corrosive environment.
- c. The controller shall be protection from salt air or salt water environments as anticipated.
- d. The minimum level of protection for corrosive environments shall be NEMA Type 4X organic coating that has been salt spray tested (ANSI/UL 50E or CSA 22.2 No. 94.)

### 4.14.3 Power Components

#### 4.14.3.1 Bypass Path

- a. The Bypass path shall comprise a complete full service fire pump controller.
- b. All internal components and the external emergency run handle/lever (external emergency run mechanical operator) shall meet all of the requirements of this standard as specified for Automatic Electric Motor Driven Fire Pump Controllers, and be listed for the horsepower of the motor unit.
- c. The bypass path shall be one of the following types:
  - A-T-L (D-O-L) Full Voltage Across-The-Line Starting (Direct On Line), or;
  - Reduced Inrush (Reduced Voltage) Starting.
- d. When Wye-Delta (Star-Delta) reduced voltage starting is employed, the Wye (Star) contactor shall be electrically and mechanically interlocked to the M2 contactor (2nd Run contactor) to prevent inadvertent short circuit of the power supply.
- e. When Autotransformer reduced voltage starting is employed, the Wye/neutral contactor shall be electrically and mechanically interlocked to the Main contactor (Run contactor) to prevent inadvertent short circuit of the power supply.

#### 4.14.3.2 Variable Speed (VSD) Path

##### 4.14.3.2.1 Circuit Protection

- a. The VFD circuit shall employ circuit protection. This circuit protection shall be fuses or circuit breakers.
- b. The variable speed path circuit protection (VSDCP) shall be suitable for the short circuit rating of the controller
- c. The coordination shall be checked at no less than the following points for each controller rated horsepower and voltage (VSDCP must always trip first):
  1. 300 percent of Motor FLA - 30 minutes max. VSDCP trip or open
  2. 600 percent of Motor FLA - 7 seconds max. VSDCP trip or open
- d. The 300 percent and 600 percent coordination shall apply for the following two conditions:
  1. The controller Circuit Breaker Normal Setting (Shunt Trip Circuit) for the rated horsepower and voltage
  2. The next lower setting or 90 percent of Motor FLA if numerically set.

- e. Circuit protection shall be coordinated with the Circuit Breaker, and the Isolating Switch if a self protection type, such that no short circuit in the VSD path will result in tripping of the Circuit Breaker or the Isolating Switch. (**Note:** Typical VFDs are self protected only in regards to their output circuitry.)
- f. Circuit protection shall be installed ahead of any other components in the VSD path so as to prevent the fire pump Circuit Breaker or Isolating Switch from tripping in the event of a short circuit anywhere in the VSD circuitry, wiring or components.
- g. When overcurrent protection must be coordinated with the VFD to meet the controller short circuit rating and first trip characteristic, circuit protection for the VFD shall meet the short circuit and withstand rating of the fire pump controller. The following applies:
  - 1. This coordination shall be in addition to, and not in lieu of, that required to prevent the controller circuit breaker from tripping due to any fault in the VSD path.
  - 2. The short circuit rating of the controller is the lesser rated of the two paths, namely, the Bypass Path and the VSD path.
- h. Where fuses are used as circuit protection, the following applies:
  - 1. There shall be one fuse in each ungrounded conductor circuit;
  - 2. The fuses and fuse holder shall be listed for service;
  - 3. The fuses (fuse holder) shall be readily accessible for replacement.
  - 4. A complete set of spare fuses shall be supplied with the controller by the controller manufacturer.

#### 4.14.3.2.2 Isolation

The VFD shall be unpowered when the controller is in the stand-by state to avoid excessive wear and to prolong the life of the VFD.

- a. A line side and a load side contactor shall be supplied
- b. Both contactors shall be fully rated in horsepower or motor FLA for continuous duty.
- c. The load side contactor shall be mechanically and electrically interlocked with the Bypass contactor to prevent back feeding power to the VFD output circuit.

- 4.14.3.2.3 A line reactor rated for continuous duty shall be provided. It shall be wired ahead of the VFD. It shall have a 5 percent impedance rating as a minimum to avoid capacitor and rectifier damage, to prevent capacitor overvoltage shutdown of the VFD, and to reduce the input current harmonics to near sinusoidal in order to prevent overheating the VFD input circuit components and wiring. This reactor is required whether or not the Controller or its VFD also contain a D.C. Link Reactor, Choke (inductor) or Swinging Choke.

**Note:** By being ahead of the VFD, a line reactor protects the input rectifiers or SCRs as well as reducing capacitor current (ripple current) and capacitor over-voltage (and over-voltage trip) in the energy storage capacitors. A D.C. Link Reactor or Choke does not protect the input rectifiers or SCRs from line voltage transients.

- 4.14.3.2.4 A D.C. Link reactor rated for continuous duty at the D.C. Link current when the VFD is delivering full load (motor FLA) current shall be provided for VSD units rated at 100 hp (75 kW) or larger. It shall have a minimum 2 percent impedance rating to prevent capacitor and rectifier damage, and to prevent capacitor overvoltage shutdown of the VFD.

## 4.14.3.2.5 The VFD employed shall be suitable for fire pump applications.

- a. For centrifugal pumps or vertical turbine (non-regenerative) pumps, the VFD may be rated for either Constant Torque or Variable Torque loads.  
**Note:** Constant Torque rated drives have larger components. They are typically the next higher horsepower rating than a similarly rated variable torque drive. [i.e. A 100 hp (75 kW) Constant Torque VFD will be built similarly to a 125 hp (95 kW) rated Variable Torque VFD.]
- b. For Positive Displacement pumps, the VFD shall be rated for Constant Torque loads.
- c. For all other pump types, the VFD shall be rated for Constant Torque loads unless the design is examined and found suitable for use with Variable Torque rated VFDs.
- d. The VFD shall be suitable for use with motors that meet the following requirements:
  1. Motors built to NEMA MG-1 part 31; Inverter Duty Motors
  2. NEMA Design "B"
  3. NEMA Starting Code "F" or "G"
  4. NEMA Starting Code "F" or "G" or "H" for motors rated at 7.5 hp (5 kW) or 10 hp (7.5 kW)
  5. NEMA Starting Code "F" or "G" or "H" or "J" for motors rated at 5 hp (5 kW)  
**Note:** Inverter duty motors which are not rated for bypassing and therefore not suitable for full voltage (A-T-L, D-O-L) starting which is required for the External Emergency Mechanical Operator shall not be used with the VFD.  
**Note:** Motors used with variable speed controllers that meet the applicable requirements of NEMA MG-1 Part 31 shall be marked for inverter duty, and also shall be marked as complying with NEMA Design B standards.
- e. It's horsepower or current rating shall be listed for service and Certified.
- f. It's Pollution Degree rating per ANSI/UL 508C *Standard for Safety for Power Conversion Equipment* and IEC 60947-1, *Low-Voltage Switchgear and Controlgear - Part 1: General rules*, shall be suitable for the environment provided by the fire pump controller enclosure.
- g. The VFD shall have an output torque or current rating no less than 110 percent of the motor FLA (FLC) for no less than 60 seconds, as listed for service and Certified.
- h. The VFD shall have an output torque or current rating no less than 150 percent of the motor FLA (FLC) for no less than 10 seconds without tripping off line or damaging the VFD, as listed for service and Certified.
- i. The temperature rating of the VFD shall equal or exceed the internal temperature of the fire pump controller when running at motor FLA and with an external temperature of +104 °F (+40 °C). As a minimum, the VFD must be rated to operate at a temperature of +122 °F (+50 °C).
- j. The voltage spikes at the modulating frequency or harmonics shall not exceed the motor insulation voltage rating, (See Section 3.2.7.12).

## 4.14.3.2.6 Cooling

Cooling means shall be provided to prevent the fire pump controller internal temperature from exceeding the continuous duty listing and Certified temperature

rating of the VFD when operating at full motor load (FLA) and in an external ambient temperature of +104 °F (+40 °C).

- a. Cooling means shall be rated for continuous duty.
- b. Cooling means shall be suitable for the application, where suitability includes, as a minimum:
  1. Ambient temperature
  2. Moisture
  3. Life of the cooling means
  4. Reliability
  5. Dirt, dust, salt air, corrosive atmosphere
  6. Serviceability
- c. Cooling means shall not diminish the enclosure NEMA Type rating or IEC IP Code designation of the fire pump controller.
  1. The cooling means shall be listed for service and Certified to have the same or better NEMA Type rating or IEC IP Code designation as the fire pump controller
- d. Cooling means shall be activated whenever the VFD runs.
- e. The controller manufacturer shall provide calculations and conduct witnessed tests to demonstrate correct design and ability of the cooling system for the intended controller horsepower ratings.
- f. Cooling means shall use passive and active methods as necessary to regulate the VFD enclosure temperature under worst case conditions, and prevent dust, dirt and other airborne contaminants from entering the VFD enclosure.
  1. Conductive fins (heat sink back plate) in combination with a closed loop cooling system (i.e. air to air heat pump exchanger) is a reliable practice.
  2. Natural or forced convection are not acceptable cooling methods for VFD controllers since these methods can introduce airborne contaminants into the VFD enclosure.
- g. Cooling means shall be of simple, reliable and efficient design, and not add unnecessary mechanical and electrical complexity unless required by special environments. Cooling means requiring special power considerations shall be evaluated on a case-by-case basis.

#### 4.14.4 Control Equipment and Components

##### 4.14.4.1 Controls Security

All control devices required to keep the controller in automatic operation shall be within lockable cabinet(s), which includes:

4.14.4.1.1 Any means for changing the pressure set point of the VFD,

4.14.4.1.2 Any means of setting or changing any other VFD parameters. Among these are, as a minimum:

- a. Maximum output frequency
- b. Idle (minimum) frequency
- c. Ramp times
- d. PID (Proportional Integral Differential) parameters
- e. Overload settings
- f. Shutdown disables

- g. Shutdown parameters
- h. Alarm parameters
- i. Maximum motor torque (max. output current)
- j. Motor parameters (Horsepower, poles, impedances, etc.)

#### 4.14.4.2 Pressure control

4.14.4.2.1 The controller shall have a means of setting and displaying the desired system operating pressure set point (setting on VFD), as follows:

- a. If maintained in digital memory, said memory shall be of the non-volatile type.
- b. The system pressure set point (VFD) shall be independent of the controller start (pump demand) and stop pressure settings, and shall be independent of the method used to set the start and stop pressure settings.
- c. The pressure feedback transducer shall be independent of the controller demand (start & stop) pressure switch or transducer.
- d. Each VSEFPC shall have its own pressure feedback transducer.
- e. Each such VSEFPC shall operate independent of any common or central control when a demand for the fire pump occurs, including at a minimum the following demands:
  - 1. Local Start Pushbutton
  - 2. Pressure Switch Trip (Pump Pressure Demand)
  - 3. Remote Deluge Trip, when the controller is so equipped
  - 4. Remote Start Pushbutton Activation, when the controller is so equipped
  - 5. Weekly Test, when the electric fire pump controller is so equipped and at the discretion of the authority having jurisdiction. The certification agency requires that all weekly tests be conducted manually, and that there is a means to disable any automatic weekly test timers.
- f. The pressure feedback transducer shall be connected to the same pressure sensing line as the controller start/stop pressure switch/transducer.

**Note:** The pressure sensing line is connected between the discharge side of the check valve and the inlet side of the indicating control valve (downstream of the pump discharge).

4.14.4.2.2 The controller VFD shall have a PID (Proportional Integral Differential Process Controller) for pressure controlling means to control the speed of the pump to maintain the set point pressure, with the following requirements:

- a. The PID shall have sufficient control of time constants in order to prevent oscillation of the pump speed.
- b. The PID shall have sufficient control of time constants in order to prevent undue overshoot of the set point pressure, especially upon pump start-up under both no flow and full flow conditions.
- c. The PID shall have sufficient control of time constants in order to prevent undue undershoot of the set point pressure (i.e., undue delay in achieving the required pump speed.)
- d. The PID shall have sufficient gain in order to maintain the pressure set point within  $\pm 1.0$  psi ( $\pm 5$  kPa) when running under steady state conditions.
- e. The controller shall have means to allow setting gain and time parameters in the field.
- f. If all operating parameters are stored in digital memory, the digital memory shall be of the non-volatile type.

## 4.14.4.2.3 Markings:

The variable speed electric motor driven fire pump controller shall be marked per Section 3.3.3 of this standard.

4.14.4.2.4 The controller manufacturer shall provide a means to verify the VSD dynamic characteristics. Such means (i.e. pressure recorder or data monitor) shall record system pressures with sufficient pressure and time resolution (typically 3 samples per second) to display the fastest system hydraulic time constant.

4.14.4.2.5 When required or requested, the controller shall have a means for connecting a second pressure sensing line for the feedback VFD transducer.

**Note.** Applies in situations where the normal controller start/stop (pressure switch) pressure sensing line is not available or not suitable as the second pressure sensing line.

## 4.14.4.3 Mode Control

**Note:** The VFD pressure set point will normally be set above the pump start pressure setting. If automatic stopping is allowed, the VFD pressure set point must be set above the pump stop pressure setting. Automatic stopping is not allowed.

4.14.4.3.1 The controller shall have a Pressure Switch (tripped) timer to monitor how long the pressure switch remains closed (pump demand condition).

4.14.4.3.2 The controller shall have a Drive Ready timer to monitor how long it takes for a Drive Ready signal from the VFD to occur, starting from the time a pump demand (pressure switch trip) condition occurs.

4.14.4.3.3 When the time monitored by the Pressure Switch timer exceeds 15 seconds, the controller shall initiate a change to the Bypass mode, and under the following conditions:

a. This applies to initial pump demand (initial pressure switch demand).

**Note:** This would occur if the VFD can not get the pump up to the needed speed during start-up.

b. This also applies any time the pump is running under the variable speed mode (pressure switch re-trip during running).

**Note:** This would occur if the VFD fails during running.

4.14.4.3.4 The controller shall have a Mode Switch to change the operating mode from VSD operation to Full Speed operation (Bypass mode):

a. The switch shall be on the outside of the controller

b. The switch shall be a readily identifiable and convenient to the fire service during an emergency

c. When the Mode Switch is set to the Full Speed (Bypass) mode, the local Start Push Button (Manual Electrical Starting) shall start the pump in the Bypass Mode

d. When the Mode Switch is set to the VSD (Variable Speed) mode, the Local Start push button shall start the pump in the VSD mode of operation.

## 4.14.4.4 Motor Control

4.14.4.4.1 The VFD modulation frequency shall not exceed safe values for the motor and shall not cause the motor to overheat.

- 4.14.4.4.2 The Motor Idle Speed (Minimum Running Speed) shall be high enough to avoid overheating the motor.
- 4.14.4.4.3 For Variable Torque Loads (centrifugal pumps and vertical turbine pumps), said Idle Speed shall be suitable for the maximum turn down ratio specified for the motor being used.
- 4.14.4.4.4 For Constant Torque Loads, such as positive displacement pumps, the controller shall provide means (contacts or switched power) to energize an independent motor cooling fan or blower, when required to keep the fire pump motor, or agent pump motor, from overheating.
- 4.14.4.4.5 The factory programming of the VFD parameters shall limit the maximum motor operating speed to the line frequency synchronous speed. (i.e. The maximum allowable VFD output frequency shall be the line frequency, namely 60 Hz for 60 Hz systems and 50 Hz for 50 Hz systems.)

#### 4.14.4.5 Signals & Alarms

The controller shall be equipped, as a minimum, the following:

##### 4.14.4.5.1 Visible Indicators:

- a. Drive Failure to indicate when the Drive Ready timer has timed out.
- b. Bypass Mode to indicate automatic change to the Bypass (Full speed) mode of operation.
- c. Overpressure to indicate that the system pressure exceeds 115 percent of the desired System Set Point Pressure.

##### 4.14.4.5.2 Contacts

The controller shall be equipped with form "C" contacts (or both a form "A" and a form "B" contact sets) to indicate the above three conditions.

#### 4.14.4.6 Skip Frequencies

The controller (VFD) shall have means to skip over resonant frequencies (critical speeds), when present, during:

- a. Motor acceleration (ramp up)
- b. Speed modulation
- c. Ramp down, if provided.

#### 4.14.5 Normal Automatic Variable Speed (Pressure Control) Mode Operation - Mode Switch set to VSD (Variable) position

##### 4.14.5.1 Readiness Time

- 4.14.5.1.1 State of Readiness: The controller, including the VFD, shall be ready for operation and begin accelerating the motor in no more than 10 seconds.

**Note:** This requires that the sum of the controller boot-up time (if code controlled, i.e. processor controlled) and the VFD boot-up time add up to no more than 10 seconds.

- 4.14.5.1.2 For sole source pumps, the maximum acceleration time to full speed at the maximum horsepower load of the pump shall not exceed 10 seconds.



**Note:** For large systems having long time constants, and having other water supply(s), a slower ramp up (acceleration speed of motor) may be required to allow the PID to stabilize and minimize pressure overshoot, and when acceptable to the local authority having jurisdiction.

#### 4.14.5.2 Operation

The controller shall cause the two Isolation Contactors to close, energize the VFD and command it to run in the correct direction (Forward) under, as a minimum, the following conditions:

- a. Local Start Pushbutton (Local Start Demand)
- b. Pressure Switch Trip (Pump Pressure Demand)
- c. Remote Deluge Trip, when the controller is so equipped (Deluge Demand)
- d. Remote Start Pushbutton Activation, when the controller is so equipped (Remote Start Demand)
- e. Weekly Test, when the controller is so equipped, and if electrical only (Weekly Test Demand)

#### 4.14.5.3 Stopping

Upon a normal call to start condition, the controller shall remain in the VSD mode to control the motor speed and the system pressure until the pump is stopped manually, or the VFD fails and the controller defaults to the bypass (full speed) mode of operation. Automatic stopping is not allowed.. If a controller has an automatic shutdown feature, Certified controllers shall have a means to disable and lock-out the automatic shutdown feature, and the controller shall have a clear visual indication that the automatic shutdown feature is disabled or enabled.

**Note:** In the variable speed mode, the controller shall operate the pump to achieve and maintain the required set point pressure as long as a demand for water exists when the controller is set for either automatic stop or for manual stop operation. The controller shall supply the set point pressure or run the pump at full speed at all times. In the automatic stop mode of operation, the controller shall not slow or stop the pump as long as a demand for water exists.

#### 4.14.5.4 Restarting

4.14.5.4.1 The controller (and its VFD) shall allow for restarting of the motor after:

- a. A demand interruption,
- b. A power interruption
- c. A transfer switch operation
- d. Operation of the Local Stop pushbutton
- e. Transfer of the Lockout contacts, if used, to the enable mode

4.14.5.4.2 The controller shall provide positive means to accomplish restarting of the motor without excessive transient or inrush currents. Means may be one or more of the following:

- a. VFD set and able to lock in on a spinning motor and re-accelerate it,
- b. Means to cause an orderly deceleration and re-start of the motor
- c. Re-start delay

4.14.5.4.3 Restarting a stopped or interrupted running motor shall be accomplished in no more than 10 seconds.

#### 4.14.6 Bypass (Full Speed) Mode Operation

##### 4.14.6.1 Mode Switch set to the Bypass (Full Speed) position

The controller shall start the pump in the full speed mode with reduced inrush starting, when provided, when the Mode Switch is in the Bypass (Full Speed) position under at least the following conditions:

- a. Local Start Pushbutton (Local Start Demand)
- b. Pressure Switch Trip (Pump Pressure Demand)
- c. Remote Deluge Trip, when the controller is so equipped (Deluge Demand)
- d. Remote Start Pushbutton Activation, when the controller is so equipped (Remote Start Demand).
- e. When provided with a weekly test feature, this function must not interfere with any other normal starting means (i.e. local start, pressure start, remote start) or demands.

##### 4.14.6.2 Mode Switch set to the Variable (VSD) position

The controller shall change modes automatically from VSD to Full Speed (Bypass) Mode under any or all of the following conditions:

- a. The Pressure Switch timer accumulated 15 seconds (achieved its set time limit);
- b. The Drive Ready timer has accumulated 5 seconds;
- c. There is a valid pump demand, namely:
  1. Local Start Pushbutton
  2. Pressure Switch Trip
  3. Remote Deluge Trip, when the controller is so equipped
  4. Remote Start Pushbutton Activation, when the controller is so equipped
  5. When option provided, the controller may re-start the pump for a Weekly Test demand so long as this does not interfere with any other starting means or demands.

##### 4.14.6.3 Automatic Switch to Bypass

When the controller switches automatically to the Bypass (Full Speed) mode it shall remain in that mode until manually reset.

- a. The controller shall not automatically switch back to the Variable (VSD) mode.
- b. The controller shall not stop the motor, once running in the Full Speed (Bypass) mode whether or not the controller is equipped with Automatic Stop. (i.e. Automatic Switch to Bypass-Full Speed mode of operation shall result in continuous running of the pump at full speed.)

##### 4.14.6.4 Bypass Switching Sequence

Method of Mode Switching to Bypass (Full speed Operation). As a minimum, the following sequence of operation shall occur:

- a. The controller shall cause both isolation contactors to open, then;
- b. The controller shall pause for a time period of 2 to 4 seconds to allow the motor magnetic field (motor back EMF) to decay to a value that will prevent excessive inrush currents;  
**Note:** This shall allow for at least one open circuit magnetic field time constant. This will require a separate re-start time.
- c. Finally, the controller shall re-start the fire pump in the full speed mode per following conditions:

1. Starting shall be Across the Line (D-O-L) if of the A-T-L starting in Bypass Mode Type.
  2. Starting shall be in the reduced inrush (accelerating) mode if of the reduced inrush in Bypass Mode type of controller. The accelerating time setting shall not exceed 10 seconds.
- d. The controller will continue to run the pump in the Full Speed (Bypass) mode and until manually stopped.

#### 4.15 EMC requirements

The fire pump controller manufacturer and the authority having jurisdiction at the protected facility shall specify the measures to be taken with regard to electromagnetic compatibility (EMC) associated with the installation, operation and maintenance of the controllers, and shall ensure that the controllers have been examined to the EMC immunity requirements for environment A, and the EMC emission requirements for environment B (see 7.3.1 of IEC 60947-1) as presented below, and verified by the certification agency.

- a. EMC immunity requirements for environment A (low-voltage non-public networks or industrial locations) shall be applied; and
- b. EMC emissions requirements for environment B (low-voltage public networks or residential locations) shall be applied.

**Note:** These requirements represent the most severe levels for immunity and emissions and thus a fire pump controller may be installed in environment A or B.

## 5 PERFORMANCE TESTING REQUIREMENTS

Conformance of fire pump controllers to Section 2.3 of this standard shall be verified prior to any performance testing.

### 5.1 Type tests

Type tests are intended to verify compliance of the design of fire pump controllers with the requirements of this standard. Type tests shall be made on representative samples of each particular equipment. The type tests comprise the verification of:

- a. Degree of protection of enclosure;
- b. The temperature-rise;
- c. Dielectric voltage withstand properties;
- d. Performance under short circuit conditions;
- e. Pressure switch/transducer performance requirements;
- f. Controller performance under normal load conditions;
- g. Controller performance under overload conditions;
- h. Controller performance at operating limits;
- i. Performance of variable speed electric motor driven fire pump controller;
- j. Locked rotor overcurrent protection;
- k. Barrier dielectric strength;
- l. Coated printed circuit board performance;
- m. Capability of battery chargers (diesel engine fire pump controllers only);
- n. Electromagnetic Compatibility (EMC);
- o. Additional tests, as required.

5.1.1 To facilitate testing for the controller manufacturer, the following type tests shall be performed at a certification agency laboratory, or witnessed by a certified engineer at a recognized laboratory such as UL, CSA, LPCB or VDS based on the discretion of the certified engineer.

- a. degree of protection of enclosure;
- b. the temperature-rise;
- c. dielectric voltage withstand properties;
- d. performance under short circuit conditions;
- e. barrier dielectric strength;
- f. coated printed circuit board performance;
- g. Electromagnetic Compatibility (EMC).

### 5.2 Compliance with construction requirements

The equipment with its enclosure shall be constructed to withstand the stresses occurring during installation and normal use, and shall provide a specified degree of resistance to abnormal heat and fire. Verification of compliance concerns materials and mechanical and electrical properties as discussed in Section 3 and 4 of this standard.

### 5.3 Compliance with performance requirements

#### 5.3.1 Test sequences

Each test sequence is performed on a new sample. The tests shall be conducted in the order given for

each sample. The following is the recommended order of test sequences that may be adjusted according to availability of samples:

- a. Test sequence I
  - Verification of degree of protection of enclosure
- b. Test sequence II
  - Verification of coated printed circuit board performance
- c. Test sequence III
  - Verification of performance under short circuit conditions (for electric motor fire pump controllers only)
- d. Test sequence IV
  - Verification of temperature-rise;
  - Verification of dielectric properties;
  - Verification of functional and performance requirements;
  - Verification of performance under normal load and overload conditions;
  - Verification of operating limits;
  - Verification of performance of the contactor.
- e. Test Sequence V
  - Verification of variable speed electric motor driven fire pump controller performance (as applicable)
- f. Test sequence VI
  - Verification of pressure switch/transducer performance
- g. Test sequence VII
  - Verification of capability of battery chargers (for diesel engine fire pump controllers only)
- h. Test sequence VIII
  - Verification of electromagnetic compatibility, EMC

#### 5.3.2 General test conditions

- a. The equipment to be tested shall meet the requirements of Section 2.3.2 of this standard, and all testing must be witnessed by a certified engineer
- b. Each test shall be made on equipment in a clean and new condition.
- c. Tests shall be made with the same type of voltage, current, rated frequency and number of phases as in the intended service.
- d. Equipment under test shall be mounted complete on its own support, connected as in normal service, in accordance with manufacturer's instructions and evaluated under ambient temperature conditions of 39 °F to 104 °F (4 °C to 40 °C), unless otherwise directed by this standard.
- e. The tightening torques to be applied to the terminal screws shall be in accordance with the manufacturer's instructions.
- f. Equipment having an integral enclosure shall be mounted complete and any opening normally closed in service shall be closed for tests.
- g. Equipment intended for use only in an individual enclosure shall be tested in the smallest of such enclosures stated by the manufacturer.
- h. Maintenance or replacement of parts is not permitted during testing, unless allowed by the certification agency's engineer.
- i. The equipment may be operated without load prior to the beginning of a test.
- j. For the tests, the actuating system of mechanical switching devices shall be operated as for the intended use in service stated by the manufacturer and at the rated values of control quantities (such as voltage or pressure), unless otherwise specified in this standard.

#### 5.4 Degree of protection of enclosure

Enclosure environmental testing shall be conducted in accordance with NEMA 250 - *Enclosures for Electrical Equipment (1000 Volts Maximum)*, UL 50 - *Standard for Enclosures for Electrical Equipment* or in accordance with Annex C of IEC 60947-1 and IEC 60529. Enclosures for fire pump controllers (other than variable speed electric motor fire pump controllers) shall comply with the requirements for a NEMA environmental rating no lower than Type 2, or with the requirements for an IEC IP designation code of no lower than IP31. When using IEC IP designation code, care shall be taken to ensure that the IP code and test method is equivalent to the prescribed NEMA Type rating. See Appendix E for further clarification.

#### 5.5 Temperature-Rise Test

- 5.5.1 As tested under the conditions described in this procedure, fire pump controllers and associated equipment shall:
- Not attain a temperature at any point so high as to constitute a risk of fire or fire hazard or adversely affect any materials employed in the equipment;
  - Not exceed the temperature limit for any individual component within the equipment; and;
  - Not exceed the temperature rise above the test ambient at specific points greater than those specified in Table A.10 and Table A.11.

- 5.5.2 To determine whether a fire pump controller complies with the temperature test requirements, it is to be tested as described below:

Fire pump controllers shall be operated under normal conditions as described in the manufacturer's installation instructions.

Equipment shall carry its rated current continuously.

The test current for a horsepower rated device shall be as specified in Table A.6.

An auxiliary device for controlling a contactor, a relay or another magnetically operated device shall carry a test current that corresponds to the maximum break current consistent with the switch rating.

The test conditions are to be established so that each current carrying component carries the maximum rated current of the controller. Three phase controllers are to be tested on a three phase current source.

A low voltage source of supply is able to be used for temperature tests on parts other than voltage rated coils.

The temperature test shall be conducted with the fire pump controller mounted as intended in use.

The fire pump controller, or associated equipment, is to be tested in the enclosure provided by the manufacturer.

External field connections to the fire pump controller shall be made by one of the following methods:

- Fire pump controllers shall be tested with 4 ft. (1.2 m) of copper wire attached to each field-wiring terminal.
- The wire shall be of the smallest size having an ampacity of at least 125 percent of the maximum full-load motor-current in accordance with Table A.6.
- The wire size is to be in accordance with Table A.12 based on the wire temperature rating marked on the equipment.
- If the equipment is marked to limit the size of the wire, the maximum allowable wire size is to be used.
- The type of insulation is not specified.
- The temperature test may be conducted with conductors having other than black insulation, but

reference temperature measurements are to be conducted with black-insulated conductors.

- g. When there is only provision for the connection of bus bars to equipment rated at 450 A or more, 1/4 in. (6.4 mm) thick copper bus bars of the width specified in Table A.13 and at least 4 ft. (1.2 m) in length are to be used.

The temperature test shall be conducted with plated bus bars. Black-painted bus bars shall not be used.

The spacing between multiple bus bars is to be 1/4 in. (6.4 mm) with no intentional wider spacing except as necessary at the individual terminals of the equipment.

The temperature test shall be conducted with the equipment placed in one of the following locations: The ambient temperature for the temperature test shall be based on one of the following:

- a. Equipment shall be placed in the rated ambient temperature; or
- b. Equipment shall be placed in a non-air circulating test chamber with the ambient temperature of the test chamber adjusted to the rated ambient; or
- c. Equipment is able to be tested in a lower ambient temperature provided the test results are adjusted linearly to the rated ambient temperature.

If reference measurements of ambient temperatures are necessary, several thermometers shall be placed at different points around the equipment at a distance of 35 - 70 in. (900-1800 mm). The thermometers shall be located in the path of the cooling medium, but shall be protected from drafts and abnormal heat radiation. The ambient temperature shall be the mean of the readings of the temperatures taken at equal intervals of time during the final quarter of the duration of the test.

The tests on all parts shall be made simultaneously, as the heating of one part may affect the heating of another part.

The temperature test is to be conducted until temperatures are constant.

A temperature rise shall be considered to be constant when three successive readings, taken at intervals of 10 percent of the previously elapsed duration of the test (but not less than 10 minute intervals), are constant within 34 °F (1 °C).

Temperatures shall be measured by thermocouple method or by resistance method, as described below.

- a. Thermocouple method:

The thermocouple method shall consist of the determination of temperature by the application of thermocouples to the hottest accessible parts with measurement by a suitable calibrated instrument.

1. The thermocouples are to be made of wires not larger than No. 24 AWG (0.21 mm<sup>2</sup>). The thermocouples and related instruments are to be accurate and calibrated in accordance with good laboratory practice. The thermocouple wire is to conform to the requirements for special tolerance thermocouples specified in ANSI/ISA MC96.
2. A thermocouple junction and adjacent thermocouple lead wire shall be securely held in good thermal contact with the surface of the material on which the temperature is being measured. In most cases, adequate thermal contact will result from securely taping or cementing the thermocouple in place but, if a metal surface is involved, brazing or soldering the thermocouple to the metal may be necessary.

- b. Resistance Method:

The preferred method of measuring the temperature of a coil shall be the resistance method, but temperature measurements by either the thermocouple or resistance method are acceptable. The thermocouple method shall not be employed for a temperature measurement at any point at which supplementary insulation is employed.

The resistance method for temperature measurement as specified in Table A.10 and Table A.11 consists of the calculation of the temperature rise of a winding using the equation:

$$\Delta t = \frac{r_2}{r_1}(k + t_1) - (k + t_2)$$

Where:

- $\Delta t$  is the temperature rise of the winding in degrees C
- $r_2$  is the resistance of the coil at the end of the test in ohms.
- $r_1$  is the resistance of the coil at the beginning of the test in ohms.
- $t_1$  is the room temperature in degrees C at the beginning of the test.
- $t_2$  is the room temperature in degrees C at the end of the test.
- $k$  is 234.5 for copper, 225.0 for electrical conductor grade (EC) aluminum; values of the constant for other conductors are to be determined.

**Note:** As it is generally necessary to deenergize the winding before measuring resistance, determining the value of resistance at shutdown by taking several resistance measurements at short intervals, beginning as quickly as possible after the instant of shutdown, shall be permitted. A curve of the resistance values and the time shall be plotted and extrapolated to give the value of resistance at shutdown.

At the conclusion of the test, the temperature rise of each material or component shall:

1. Not attain a temperature at any point so high as to constitute a risk of fire or fire hazard or adversely affect any materials employed in the equipment;
2. Not exceed the temperature limit for any individual component within the equipment; and;
3. Not exceed the temperature rise above the test ambient at specific points greater than those specified in Table A.10 and Table A.11.

The temperature rise of a material or component is the difference between its stabilized test temperature and the test ambient.

Protective devices or circuitry shall not trip during the test.

All values for temperature rises specified in Table A.10 and Table A.11 apply to equipment intended for use in a maximum consistent ambient temperature of 104 °F (40 °C).

The suitability of insulating materials, other than those in Table A.10 and Table A.11, shall be determined with respect to properties such as flammability, arc resistance and the like, based on an operating temperature equal to 104 °F (40 °C) plus the measured temperature rise.

For industrial control equipment rated above 104 °F (40 °C), the allowable temperature rise for this elevated ambient is to be calculated in accordance with the following formula:

$$TR = TT - [TM - 104^\circ F (40^\circ C)]$$

Where:

- $TR$  is the Allowable Temperature Rise;
- $TT$  is the Maximum Temperature Rise allowed by Table A.10 and Table A.11; and
- $TM$  is the Elevated Ambient Temperature Marked on the equipment.

For industrial control equipment rated below 104 °F (40 °C), the allowable temperature rise for this reduced ambient is to be calculated in accordance with the following formula:

$$TR = TT + [104^\circ F (40^\circ C) - TM]$$



Where:

- TR* is the Allowable Temperature Rise;
- TT* is the Maximum Temperature Rise allowed by Table A.10 and Table A.11; and
- TM* is the Reduced Ambient Temperature Marked on the equipment.

Immediately following the temperature test, equipment shall be subjected to the Dielectric Voltage Withstand Test.

## 5.6 Dielectric Voltage Withstand Test

- 5.6.1 While at its maximum normal operating temperature, fire pump control equipment shall withstand for 1 minute without breakdown the application of a 60 Hz essentially sinusoidal potential or a direct-current potential:
- a. Between uninsulated live parts and the enclosure with the contacts open and closed;
  - b. Between terminals of opposite polarity with the contacts closed; and
  - c. Between uninsulated live parts of different circuits.

- 5.6.2 The test potential shall be the following values for alternating-current, or 1.414 times the following values for direct-current:
- a. 500 V – For fire pump control equipment rated not more than 50 V;
  - b. 1000 V plus twice the rated voltage of the equipment – For fire pump control equipment rated 51 - 600 V, or;
  - c. 2000 V plus 2.25 times maximum rated voltage – For fire pump control equipment rated 601 V or higher.

- 5.6.3 A transformer, a coil, an electronic part, or a similar device normally connected between lines of opposite polarity is to be disconnected from one side of the line for the test between terminals of opposite polarity with the contacts closed.

- 5.6.4 If the equipment has a meter or meters, they are to be disconnected from the circuit for the dielectric voltage-withstand test described in this section for the fire pump control equipment.

The meter or meters shall then be tested separately for dielectric strength with an applied voltage of:

- a. 1000 Volts in the case of an ammeter;
  - b. 1000 Volts plus twice the rated voltage in the case of any other instrument having a potential circuit;
  - c. 500 Volts for meters in circuits operated at 50 V or less (no test requirements are specified for meters operated at 30 V or less); and
  - d. 2000 Volts A.C. plus 2.25 times the maximum rated voltage for devices rated above 750 Volts applied between power supply circuits and any non-current-carrying metal parts.
- 5.6.5 To determine whether equipment complies with the requirements in Section 5.5, it is to be tested by means of a transformer, the output voltage of which is essentially sinusoidal and can be varied. The applied potential is to be increased from zero to the required value at a substantially uniform rate and as rapidly as is consistent with its value being correctly indicated by a voltmeter. The voltage shall be held at that value for 1 minute.

The transformer indicated above shall either:

- a. Have a capacity of 500 VA or larger; or
- b. Have a capacity of less than 500 VA, provided a voltmeter is present to directly measure the applied output potential.

A direct-current source shall be used for a direct-current circuit unless A.C. testing is agreeable to the

manufacturer and the certification agency.

For circuits having high enough capacitance (wiring capacitance) to yield false failure or leakage indication, such as transfer switch fire pump controllers, a direct-current source may be used at a voltage of 1.414 times the A.C. test voltage if agreeable to the manufacturer and the certification agency.

## 5.7 Short Circuit Test

**Note:** Test is to be done for both standard and high-fault currents.

**Test Samples:** Samples shall comprise the largest rated disconnect (isolation switch) and short circuit protective device (circuit breaker) with the smallest rated contactor and the largest internal wire size allowed to the contactor, the smallest enclosure cabinet, and the size of external cable specified in Table A.12.

The performance of a controller for electric motor driven fire pumps shall be investigated by subjecting representative samples in commercial form to the tests indicated in this section. Consideration shall be given to the individual component ratings within the controller as compared to the overall controller ratings, similarity of the individual components used in a manufacturer's line of controllers, and other criteria in determining samples for testing representative samples of a manufacturer's line of similarly constructed controllers.

Components of a sample controller identified for testing are to be selected as follows:

- a. Circuit breakers that are of the same manufacturer, rating, and frame construction are representative of other breakers.
- b. Contactors, isolating switches, and transfer switches that are of the same manufacturer, rating, and construction are representative of other similar devices.
- c. Enclosures are to be selected based upon the enclosure construction including the method of cover or door securement. In general, an enclosure having the smallest dimensions and the least provision for pressure relief is to be selected.

### 5.7.1 Test Requirements:

After completing the tests for both standard and high-fault currents specified in 5.7.2 and 5.7.3, and after the circuit breaker has cleared the fault, a controller shall comply with the following:

- a. There shall be no discharge of parts. The contactor contacts are allowed to weld or completely disintegrate.  
**Note:** Complete disintegration of the contact is considered to have occurred when the contacts are not capable of carrying rated current or if temperatures cannot be stabilized at rated current.
- b. There shall be no damage to a conductor or terminal connector and no conductor shall pull out of a terminal connector.
- c. There shall be no cracking or breakage of insulating bases to the extent that the integrity of the mounting of live parts is impaired.
- d. The door or cover shall not be blown open, and it shall be possible to open the door or cover. Deformation of the enclosure shall not result in the accessibility of live parts as determined by the use of the finger probe specified in UL 50 - *Standard for Enclosures for Electrical Equipment* or CSA 22.2 No. 14.
- e. The circuit breaker and/or isolating switch (FPC short circuit protective devices and/or disconnect), of the controller shall be capable of being opened manually with its operating handle.
- f. The fault current has been successfully interrupted by the controller and the solid wire connected between the live pole and the enclosure shall not open or has not melted.
- g. Neither end of the circuit breaker or isolation switch, (FPC short circuit protective devices or

disconnecter), when provided, shall be completely separated from the mounting means and the line terminals of the circuit-breaker or isolating switch shall not bridge from the mounting means to dead-metal.

- h. The tripping of the locked rotor protector shall be verified at a multiple of the current setting and shall conform to the tripping requirements of Section 4.2.4.4 both before and after the test.
- i. The adequacy of the insulation shall be verified by a dielectric test on the controller using an essentially sinusoidal test voltage per Section 5.8.

#### 5.7.1.1 Test Set-Up

The controller is to be mounted as intended in service and tested with 4 ft. (1.2 m) of wire attached to each load and line terminal. The wire is to be the smallest size having an ampacity of at least 125 percent of the maximum full-load motor-current rating of the current element. The wire size is to be in accordance with Table A.12 based upon the wire temperature rating marked on the equipment. When the terminal will not receive that size of wire, or the equipment is marked to limit the size of wires, the maximum wire size is to be used. The load terminal leads are to be connected together.

**Note:** The line test wires may exceed 4 ft. (1.2 m) in length if they are included in the circuit during calibration.

The metal enclosure of the controller is to be connected through a solid conductor without a fuse to the live pole that is judged to be least likely to strike the ground on the load side of the limiting impedance by a No. 10 AWG (5.3 mm<sup>2</sup>) copper wire 4 - 6 ft. (1.2 - 1.8 m) long. Exception: This connection shall be made with No. 12 or 14 AWG (3.3 or 2.1 mm<sup>2</sup>) copper wire if the branch-circuit conductors the equipment is intended to be connected to are No. 12 or 14 AWG (3.3 or 2.1 mm<sup>2</sup>), respectively.

The armature or cross bar of the magnetic motor controller (not the contacts) is to be held in the closed position either mechanically or by separate electrical circuit.

Standard fault test circuits shall be calibrated to the values specified in Table A.14 in accordance with the requirements for calibration of test circuits for the short circuit test in UL 508 or CSA 22.2 No. 14.

High fault test circuits shall be calibrated to a value specified in Table A.15 in accordance with the requirements for calibration of test circuits for the short circuit test in UL 508 or CSA 22.2 No. 14.

Three-phase tests are considered to cover single-phase tests for a device of the same design.

The enclosure cover or door is to be held closed only by the intended latch mechanism or securing device.

Following the short circuit tests; a controller is to be subjected to the Dielectric Voltage-Withstand Test in accordance with Section 5.8 of this standard.

#### 5.7.2 Short Circuit Test - Standard Fault Currents

The isolating switch, if provided, and the circuit breaker are to be in the fully closed position. The magnetic motor contactor is to be held closed by a separate electrical supply. The test circuit is to be closed on the test sample as described in Section 5.7.3 for "O" shot. Two operations ("O" shots), are required. Motor contactor contacts or the complete contactor may be replaced after the first test ("O" shot).

### 5.7.3 Short Circuit Test - High Fault Currents

Two successive operations are to be conducted by closing the circuit on the equipment ("O" shot), using random closing, and closing the equipment on the circuit ("CO" operation). Motor contactor contacts or the complete contactor may be replaced after the first test ("O" shot).

"O" shot: The circuit breaker, isolating switch and the contactor are to be in the fully closed position when closing the circuit on the equipment. The motor contactor is to be held in the closed position either mechanically or by a separate electrical circuit.

"CO" shot: The circuit breaker and isolating switch are to be in the fully closed position. The contactor is to be closed onto the test circuit by a separate electrical signal.

## 5.8 Dielectric Voltage-Withstand Test for Post Short Circuit Testing

Following the short circuit tests, a controller shall withstand without breakdown, a test potential of twice rated voltage, but not less than 900V, applied for not less than 1 minute as follows:

- a. Between line and load terminals of the circuit breaker in the open position;
- b. Between line and load terminals of the isolating switch, when provided, with the switch in an open position;
- c. Between terminals of opposite polarity with the circuit breaker and isolating switch, when provided, in an open position; and
- d. Between live parts and the overall enclosure with the circuit breaker and isolating switch, when provided, both opened and closed.

## 5.9 Pressure Switch/Pressure Transducer Tests

A pressure switch/transducer shall comply with the tests shown below. All tests shall be conducted on the same sample. The order of testing shall be as shown below.

### 5.9.1 Output Accuracy

At standard room ambient temperature, 50 °F to 104 °F (10 °C to 40 °C), and at the minimum input power (i.e. voltage or current) marked on the device, the pressure switch or transducer output reading (signal) shall be within  $\pm 5$  percent of full scale, but not more than  $\pm 15$  psi ( $\pm 105$  kPa). A minimum of 10 equidistance readings shall be taken over the full range of the device.

### 5.9.2 Repeatability

At standard room ambient temperature, 50 °F to 104 °F (10 °C to 40 °C), and using the minimum input power (i.e. voltage or current) marked on the device, when pressure is varied from zero to full scale, the output pressure curve shall retrace, within  $\pm 1$  percent of full scale, but not more than  $\pm 3$  psi ( $\pm 20$  kPa), the curve obtained for output accuracy in clause 5.9.1. The next two sets of curves, using the mid-point (nominal) of the input power marked on the device, when pressure is varied from zero to full scale, the output pressure curve shall retrace, within  $\pm 1$  percent of full scale, but not more than  $\pm 3$  psi ( $\pm 20$  kPa), the curve obtained for output accuracy as per clause 5.9.1. The last two sets of curves, using the maximum input power marked on the device, when pressure is varied from zero to full scale, the output pressure curve shall retrace, within  $\pm 1$  percent of full scale, but not more than  $\pm 3$  psi ( $\pm 20$  kPa), the curve obtained for output accuracy as per clause 5.9.1. A minimum of 10 equidistance readings shall be taken over the full range of the device for each of the five curves.

### 5.9.3 Supply Voltage Coefficient

The pressure switch/transducer accuracy shall be within  $\pm 1$  percent of full scale, but not more than  $\pm 3$  psi ( $\pm 20$  kPa) when the controller input voltage is varied from 85 percent of controller rated input voltage to 110 percent of controller rated input voltage. This coefficient is to be checked at no less than 10 equidistant pressures including zero and full scale. If the calculated input signals (i.e. voltage or

current) are within the minimum and maximum input signals performed in the repeatability test per clause 5.9.2, then this test is not required.

#### 5.9.4 Pressure Capability (Overpressure Withstand)

After sustaining 133 percent of the maximum rated working pressure for at least 5 minutes, the pressure switch/transducer shall be tested at standard room ambient temperature 50 °F to 104 °F (10 °C to 40 °C) and using the minimum input power marked on the device, when pressure is varied from zero to full scale, the output pressure curve shall retrace, within  $\pm 1$  percent of full scale, but not more than  $\pm 3$  psi ( $\pm 20$  kPa), the curve obtained for output accuracy as per clause 5.9.1.

#### 5.9.5 Temperature Coefficient (Temperature Drift)

5.9.5.1 After a 12 hour conditioning period at an ambient temperature of 34 °F to 36 °F (1 °C to 2 °C), the pressure switch/transducer; using the minimum input power marked on the device and when pressure is varied from zero to full scale and back, the output pressure curve shall retrace, within  $\pm 1$  percent of full scale, but not more than  $\pm 3$  psi ( $\pm 20$  kPa), the curve obtained for output accuracy as per clause 5.9.1. A minimum of 10 equidistance readings shall be taken over the full range of the device.

**Note:** To facilitate testing of the temperature conditioned device, the device may be removed from the conditioning temperature chamber to record output pressures, but all readings must be completed within 3 minutes after the test device is withdrawn from the conditioning temperature chamber.

5.9.5.2 After a 12 hour conditioning period at an ambient temperature of 140 °F (60 °C), the pressure switch/transducer; using the minimum input power marked on the device and when pressure is varied from zero to full scale and back, the output pressure curve shall retrace, within  $\pm 1$  percent of full scale, but not more than  $\pm 3$  psi ( $\pm 20$  kPa), the curve obtained for output accuracy as per clause 5.9.1. A minimum of 10 equidistance readings shall be taken over the full range of the device.

**Note:** To facilitate testing of the temperature conditioned device, the device may be removed from the conditioning temperature chamber to record output pressures, but all readings must be completed within 3 minutes after the test device is withdrawn from the conditioning temperature chamber.

#### 5.9.6 Endurance

The device shall be subjected to 6,000 pressure fluctuation cycles. Each cycle shall be from zero pressure to no less than rated full scale pressure. The device power terminals shall be connected to an electrical load equal to the maximum rating of the device. There shall be no failures, and the device at standard room ambient temperature, 50 °F to 104 °F (10 °C to 40 °C), and using the minimum input power marked on the device, when pressure is varied from zero to full scale, the output pressure curve shall retrace, within  $\pm 1$  percent of full scale, but not more than  $\pm 3$  psi ( $\pm 20$  kPa), the curve obtained for output accuracy as per clause 5.9.1.

#### 5.9.7 Dielectric Strength (Voltage Withstand)

The pressure switch/transducer shall meet the following test criteria.

5.9.7.1 Where the switch/transducer operating (power supply) voltage is 50 Volts or less, a test voltage of 500 V A.C. shall be applied between the electrical terminals and the exterior surface or the pressure fitting for a period of one minute. The measured leakage current shall be less than 5mA and there shall be no evidence of arcing or breakdown.

5.9.7.2 Where the switch/transducer operating (power supply) voltage exceeds 50 Volts, a test

voltage of 1000V A.C. + 2 times the operating voltage shall be applied between the electrical terminals and the exterior surface or the pressure fitting for a period of one minute. The static discharge shall be less than 5mA and there shall be no evidence of arcing or breakdown.

**Note:** Some transducer designs use capacitors in the circuitry and ground the entire circuit to the metal body or casing. With such designs, the manufacturer must provide a sample with the circuit grounding detached from the body in order to perform the dielectric strength test on the insulation properties of the device and avoid a false reading.

For circuits having high enough capacitance (wiring capacitance) to yield false failure or leakage indication, a direct-current source may be used at a voltage of 1.414 times the A.C. test voltage if agreeable to the manufacturer and the certification agency.

#### 5.9.8 Burst Pressure

After sustaining 2 times the maximum rated working pressure, or at least 2000 psi (13 790 kPa), for a minimum of 5 minutes, the device shall not rupture nor shall it leak.

### 5.10 Verification of Performance under Normal Conditions

5.10.1 The controller shall be loaded to attain a steady-state temperature of 77 °F (25 °C). The controller shall be stopped and started by use of its normally operating means three times, and all responses, sequences, signals and alarms shall operate correctly as intended and as specified in Section 4 of this standard. When the controller is provided with an automatic power transfer switch, it shall be verified that the transfer switch responds correctly upon loss of normal supply, and all responses, sequences, signals and alarms shall operate correctly as intended, and as specified in Section 4 of this standard.

5.10.1.1 A controller for an electric motor driven fire pump shall be connected to no smaller than 15 hp (10 kW) rated motor and all alarm conditions shall be manipulated through a test set or apparatus connected to the respective control board terminals inside the controller. The power supply to the controller must have means to adjust voltage and frequency on each phase, and interrupt the current signal on each phase.

5.10.1.2 A controller for a diesel engine driven fire pump shall be connected to a 12 Volt or 24 Volt battery set, and typical power source as in normal installation. The controller shall also be connected to a test simulator device or apparatus that is comparable to a 100 hp (75 kW) diesel engine. As a minimum, the loads on terminals #1, #9 and #10 (fuel/water and cranking contactors) shall be no less than 10 amperes at the nominal engine and controller voltage (12 Vdc or 24 Vdc, for example). On controllers equipped for Energize to Stop engines, the load on terminal #12 (shutdown solenoid) shall be no less than 10 amperes. All alarm conditions shall be connected from the control board terminals inside the controller to the test set/apparatus, and manipulated by the appropriate electrical signal.

5.10.2 Verification of manually activated device for low-voltage and high (medium) voltage electric fire pump controllers

#### 5.10.2.1 Low-Voltage Electric Fire Pump Controller

The following requirements apply to the manually activated device (emergency-run mechanical control at controller) where the closing operation is made by direct manual operation without an interposing mechanism. The time period for the complete contact closing operation shall be determined as follows with the controller at 115 percent of the rated voltage and current:

- a. The equipment shall be operated 15 times manually under no-load conditions in

accordance with the manufacturer's instructions and with any electrical assist devices disconnected. The operation shall be conducted five times by each of three persons. The closing time period of the hand actuator at the instant of contact closure of the last closing contact shall be determined by oscillographic or other appropriate means at any convenient part of the device;

- b. The point at which the measurement is made and the time period at the measurement point shall be recorded. The mean closing time period shall be determined after deleting the highest and lowest values;
- c. The test apparatus shall ensure that the equipment under test fully closes and that there is no impediment to the free closing movement of the device. The mean manual closing time period shall be greater than the automatic electrical closing time period.
- d. The operation of the manually activated device shall also meet the requirements of Section 5.10.3 of this standard.

#### 5.10.2.2 High (Medium) voltage electric fire pump controller

The following requirements apply to the manually activated device (emergency-run mechanical control at controller) where the closing operation is made by direct manual operation without an interposing mechanism. The time period for the complete contact closing operation and the complete contact opening operation shall be determined as follows with the controller at 115 percent of rated voltage and current:

- a. The equipment shall be operated 15 times manually under no-load conditions in accordance with the manufacturer's instructions. The operation shall be conducted five times by each of three persons. The closing time period of the hand actuator at the instant of contact closure, and the opening time period of the hand actuator at the instant of complete contact opening of the last contact shall be determined by oscillographic or other appropriate means at any convenient part of the device;
- b. The point at which each measurement is made and the time period at each measurement point shall be recorded. The mean closing time period and the mean opening time period shall be determined after deleting the highest and lowest values;
- c. The test apparatus shall ensure that the equipment under test fully closes and fully opens, and that there is no impediment to the free closing and opening movement of the device. The manual closing and manual opening time period shall match or be less than the time period for automatic electrical closing and automatic electrical opening of the contactor.
- d. The operation of the manually activated device shall also meet the requirements in Section 5.10.3 of this Standard.

#### 5.10.3 Behavior of equipment during manually activated device tests:

- a. The equipment shall perform during the above tests in such a manner as not to endanger an operator or cause damage to adjacent equipment.
- b. There shall be no permanent arcing or flash-over between poles or between poles and frame, and no melting of the fuse in the detection circuit.
- c. A closing operation is considered satisfactory when normal operation of the handle through its full stroke will close the contacts sufficiently for the equipment to be able to carry its rated operational current.

#### 5.10.4 Wire Flexing Test

The wiring to components mounted on a door is to be tested by opening the door as far as possible - restraints such as a chain are to remain in place - and then closing it for 500 cycles of operation. Following this test, the equipment is to be subjected to the dielectric voltage withstand test described in Section 5.6 (shall be twice rated V +1000V +20 percent for 1 second) applied between conductors, and

between conductors and ground with the door in the fully opened position.

#### 5.10.5 Phase Loss Detection Test

- 5.10.5.1 As a result of the tests described below, the visual indicators shall indicate the loss of phase, and the contacts for the alarm circuits shall change state.

Phase loss is to be evaluated using two methods. The first method requires dropping the voltage on each phase below 75 percent of rated voltage. The second method requires each power wiring lead on the input (line) side of the controller to be disconnected from its source of supply while other leads remain intact. The test is to be performed with a minimum 15 hp (10 kW) rated motor. Electrical starting capability shall be automatically restored within 10 seconds upon the return of good power conditions.

The test is to be performed under the following conditions:

- a. While the motor is running unloaded at rated voltage; and
  - b. With the motor at rest.
- 5.10.5.2 When an electric fire pump controller is equipped with a loss of phase protection feature, the voltage threshold (drop out) for any circuit or component whose principal and primary function is protection of the motor from a loss of phase of the power source shall not exceed 70 percent of the nominal line voltage.

It is the intent of this requirement for the manufacturer to design the optional feature in a manner that would not, in the event of a component failure in its most likely failure mode, impair the automatic starting or the continued operation of the motor. Due to the large variation in possible manufacturer design approaches, a detailed analysis of the design is required to determine the required testing approach. At a minimum, key components shall be shorted or opened, as appropriate, to determine the resultant impact on the automatic starting or continued operation of the motor.

The controller shall be operating under normal load (motor running) conditions and each incoming phase shall be opened one at a time. In each case, it shall be verified that the phase loss protection feature does not interfere with the controller's ability to supply power to the remaining two phases of the motor, even at low rpm and locked rotor conditions.

The controller shall be powered and in a "ready to start" condition. The incoming line voltage shall be individually reduced on each of the three phases. The voltage at which the phase loss protection feature activates and prohibits the starting of the motor shall be less than 70 percent of the controller's required nominal voltage in all cases.

The controller shall be powered and in a "ready to start" condition. The incoming line voltage shall be reduced on one phase until the phase loss protection is activated. The voltage shall then be increased to 85 percent of nominal and the time measured between this increase in voltage and the restoration of automatic starting capability of the controller. This shall be less than 10 seconds in all cases.

### 5.11 Controller Phase Calibration

A calibration test is to be performed as follows:

1. With three phase current flowing in the three poles and balanced within  $\pm 10$  percent maximum difference between the three measured currents,
  - 2a. With single phase current flowing into Phase A and out of Phase B,
  - 2b. With single phase current flowing into Phase A and out of Phase C,



- 2c. With single phase current flowing into Phase B and out of Phase C,
- 3a. With single phase current flowing into Phase A to ground,
- 3b. With single phase current flowing into Phase B to ground,
- 3c. With single phase current flowing into Phase C to ground.

## 5.12 Verification of Operating Limits

- 5.12.1 The controller shall be loaded (or conditioned for a minimum of one hour), to attain a steady-state temperature of 104 °F (40 °C). Operating tests shall be conducted at 85 percent and 110 percent of the rated control supply voltage  $U_s$ , and at 115 percent of rated full load current (FLC). Where a range is declared, 85 percent shall apply to the lower value and 110 percent to the higher. The controller shall be stopped and started by use of its normally operating means three times, and all responses, sequences, signals and alarms shall operate correctly as intended and as specified in Section 3 and Section 4 of this standard. The limit for which the controller shall drop out is 75 percent of the rated control supply voltage  $U_s$ .
- 5.12.2 The controller shall be conditioned for a minimum of one hour to attain a steady-state temperature of 39 °F (4 °C). Operating tests shall be conducted at 85 percent and 110 percent of the rated control supply voltage  $U_s$ , and at 115 percent of rated full load current (FLC). Where a range is declared, 85 percent shall apply to the lower value and 110 percent to the higher. The controller shall be stopped and started by use of its normally operating means three times, and all responses, sequences, signals and alarms shall operate correctly as intended and as specified in Section 3 and Section 4 of this standard. The limit for which the controller shall drop out is 75 percent of the rated control supply voltage  $U_s$ .
- 5.12.3 When the controller is provided with an automatic power transfer switch, it shall be verified that the transfer switch responds correctly upon loss of normal supply, and all responses, sequences, signals and alarms shall operate correctly as intended, and as specified in Section 3 and Section 4 of this standard, during operating tests conducted at 85 percent and 110 percent of the rated control supply voltage  $U_s$ , at 115 percent of rated full load current (FLC), and at steady-state temperatures of 39 °F (4 °C) and 104 °F (40 °C).
- 5.12.4 Meter accuracy. The variation in the voltmeter and ammeter readings of the controller's meters shall be determined at controller input voltages of 85 percent of  $U_s$  and 110 percent of  $U_s$ . The readings on any phase voltage or phase current shall not vary by more than  $\pm 5$  percent of the reading at 100 percent of  $U_s$ .
- 5.12.5 Test Set-up
  - 5.12.5.1 A controller for an electric motor driven fire pump shall be connected to no smaller than 15 hp (10 kW) rated motor and all alarm conditions shall be manipulated through a test set or apparatus connected to the respective control board terminals inside the controller. The power supply to the controller must have means to adjust voltage and frequency on each phase, and interrupt the current signal on each phase.
  - 5.12.5.2 A controller for a diesel engine driven fire pump shall be connected to a 12 Volt or 24 Volt battery set, and typical power source as in normal installation. The controller shall also be connected to a test set or apparatus that is comparable to a 100 hp (75 kW) diesel engine. As a minimum, the loads on terminals #1, #9 and #10 (fuel/water and cranking contactors) shall be no less than 10 amperes at the nominal engine and controller voltage (12 Vdc or 24 Vdc, for example). On controllers equipped for Energize to Stop engines, the load on terminal #12 (shutdown solenoid) shall be no less than 10 amperes. All alarm conditions shall be connected from the control board terminals inside the controller to the test set/apparatus, and

manipulated by the appropriate electrical signal.

### 5.13 Verification of performance for Variable Speed Electric Motor Driven Fire Pump Controllers

Variable speed electric motor driven fire pump controllers will be tested to verify all requirements for electric motor driven fire pump controllers as stipulated in this standard, and tested to verify compliance with all requirements in Section 3.2.7 and Section 4.15 for the variable speed components of the controller and the variable frequency drive (VFD). The VFD will be evaluated at ambient temperatures of 39 °F (4 °C) and not less than 104 °F (40 °C). All functionality, responses, sequences, signals and alarms shall operate correctly as specified. The temperature rise inside the controller shall not exceed 50 °F (10 °C) or the lower of the ambient temperature rating of the VFD unit, after being conditioned for one hour at its maximum external ambient temperature rating and while operating at full load amps. The maximum heat dissipation rate from the controller, VFD and power path components will be recorded during testing.

5.13.1 Certification will be based upon evaluation of the smallest and largest variable speed drive being implemented by the controller manufacturer. The selected sizes of VSEFPC shall be connected to no smaller than 15 hp (10 kW) rated motor and operated at its minimum and maximum rated ambient working temperature for one hour, adjusted for various system pressure set points, and subjected to various pressure and flow conditions to verify its full range of capability. Both the pump suction pressure and pump discharge pressure will be randomly changed in no less than 50 different combinations for each VFD size to simulate possible hydraulic changes to the fire protection system. Half the test scenarios will be conducted at minimum rated ambient temperature and 85 percent supply voltage, and half the test scenarios will be conducted at maximum rated ambient temperature, with 110 percent of the rated control supply voltage, and full load amps. For each scenario, the variable speed drive must adjust to the changing hydraulic conditions within 10 seconds without oscillation, overshoot of pressure set point, undershoot of pressure set point, and maintain the pressure set point within  $\pm 1.0$  psi ( $\pm 5$  kPa) after attaining steady state conditions.

5.13.2 Transducer water pressure, ambient temperature, controller and VFD internal temperature, controller voltage and current supply, motor frequency and motor rpm will be monitored and recorded during all testing.

**Note:** Motors rated for 60 Hertz will typically idle at 40 Hertz and be at full load speed at 60 Hertz.

5.13.3 Final certification will be based upon satisfactory field acceptance testing of a VSEFPC unit (typically the largest size) on-site. Verification will also be made in the field that operation at reduced pump speed does not result in electric motor overheating.

### 5.14 Locked Rotor Overcurrent Protection Test (Locked-Rotor Withstand Current Test)

When tested in accordance with the procedures below, the locked rotor overcurrent protection feature of a fire pump controller shall:

- a. Not trip at 300 percent of motor full load current;
- b. Trip the circuit breaker (overcurrent protective device) between 8 and 20 seconds at 600 percent of motor full load current.
- c. Trip the circuit breaker (overcurrent protective device) between 8 and 20 seconds at a load of 7.2 times the rated current of the motor, for energy efficient motors under 15 hp (10 kW).
- d. Be able to be manually reset immediately after tripping, with the tripping characteristics unchanged, in that there is no more than a 10 percent variance between any one test data point and the mean average for that set of test data.

The fire pump controller/locked rotor overcurrent protection shall be mounted as intended. Wiring connections shall be made as described in the Temperature Test in Section 5.5.2. Any convenient voltage source (minimum

100V) may be used to provide the specified test current. The fire pump controller/locked rotor overcurrent protection shall be tested at ambient temperatures of 77 °F and 122 °F (25 °C and 50 °C).

Test 1: A test current equal to 600 percent of the rated motor full load current shall be generated by using any convenient test voltage and shall be sent through the fire pump controller or otherwise detected by the locked rotor overcurrent protector. The time from initial current generation to the time the locked rotor overcurrent protector trips to open the circuit shall be recorded.

Immediately after Test 1, the locked rotor overcurrent protective device (circuit breaker) shall be manually reset and the following test conducted.

Test 2: A test load equal to 7.2 times the rated current of the motor shall be generated by using any convenient voltage source (minimum 100 V A.C.) and shall be sent through the fire pump controller for 20 seconds. During the test, the contacts of the electromagnetic contactor shall be held in the closed position by the operating coil supplied by the rated control voltage. The time from initial current generation to the time the locked rotor overcurrent protector trips to open the circuit shall be recorded.

Immediately after Test 2, the locked rotor overcurrent protective device (circuit breaker) shall be manually reset and the following test conducted.

Test 3: A test current equal to the 300 percent of the rated motor full load current (FLC) shall be generated by using any convenient voltage source (minimum 100 V A.C.) and shall be sent through the fire pump controller for 5 minutes. Then, a simulated signal with the value equivalent to 300 percent of motor FLC shall be applied to the trip unit (locked rotor overcurrent protector) for 30 minutes. In both cases, the controller and trip circuitry shall not trip.

Immediately after Test 3, the trip unit (locked rotor overcurrent protective device, i.e. circuit breaker) shall be manually reset and the process in Test 1, Test 2 and Test 3 repeated three more times (4 times total each).

**Note:** As an option to alternating the tests at 300 percent, 600 percent of motor full load current, and at 7.2 times rated motor current, all four trials may be conducted at one value (for example at 300 percent in succession) before continuing with the tests at the remaining values, provided the same sample is used.

The same sample shall be used for all 12 trials (4 trials at 300 percent, 4 trials at locked rotor, 4 trials at 7.2 times rated motor current).

### 5.15 Barrier Dielectric Strength Test

A polymeric material used as a barrier at a thickness less than specified in Section 4.1.6 shall comply with the test described in Test 1 or Test 2 below.

Test 1: A sample of the polymeric material, at its used thickness, shall withstand for 1 minute a dielectric voltage of 5000 V<sub>rms</sub>, 50-60 Hz, both after conditioning for:

- a. 40 hours at 73.4 °F ± 3.6 °F (23.0 °C ± 2 °C) and 50 ± 5 percent relative humidity; and,
- b. 96 hours at 95.0 °F ± 3.6 °F (35.0 °C ± 2 °C) and 90 ± 5 percent relative humidity.

Test 2: Subjected to a 60 second Dielectric Voltage Withstand Test using the A.C. RMS test voltage values of Table A.16 or Table A.17 as applicable, corresponding to the required through-air spacing.

### 5.16 Printed Circuit Board Coating Performance Test

5.16.1 General: For printed circuit boards in which transients are limited, spacings reduced, and parts coated as permitted by Table 5.16.1, the suitability of the coating shall be determined by subjecting three samples to the tests specified in clauses 5.16.2 through 5.16.5. (Testing to the requirements of UL 840,

*Standard for Safety for Insulation Coordination Including Clearances and Creepage Distances for Electrical Equipment* Section 15 are also acceptable.)

A total of 3 coated printed-circuit board samples of each base material/coating combination shall be tested. Each sample shall be:

- a. Representative of production, containing such items as inks and solder resists if used in the production process;
- b. Provided with the minimum creepage (spacings) distance that is to be used in the final printed-circuit board assembly using the conductor and coating patterns shown in Figure B-10;
- c. Provided with the minimum thickness of coating to be used in the final printed-circuit board assembly;
- d. Provided with attached lead wires that are suitable for the dielectric test voltage and conditioning temperature; and
- e. Prepared by normal production means using the primer or cleaner employed by the end-product manufacturer.

*Table 5.16.1 Minimum Conductor Spacings for Printed Circuit Boards<sup>1</sup>*

<i>Volts A.C. rms or D.C.</i>	<i>Transients not limited in. (mm)</i>		<i>Transients limited</i>			
			<i>Coated<sup>2</sup></i>		<i>Uncoated</i>	
	<i>in.</i>	<i>(mm)</i>	<i>in.</i>	<i>(mm)</i>	<i>in.</i>	<i>(mm)</i>
50	0.034	(0.85)	0.001	(0.025)	0.002	(0.04)
100	0.039	(1.0)	0.004	(0.10)	0.006	(0.16)
125	0.041	(1.05)	0.006	(0.16)	0.010	(0.25)
160	0.043	(1.1)	0.010	(0.25)	0.016	(0.40)
200	0.055	(1.4)	0.016	(0.40)	0.025	(0.63)
250	0.071	(1.8)	0.022	(0.56)	0.039	(1.0)
320	0.086	(2.2)	0.029	(0.75)	0.063	(1.6)
400	0.110	(2.8)	0.039	(1.0)	0.079	(2.0)
500	0.142	(3.6)	0.051	(1.3)	0.098	(2.5)
630	0.177	(4.5)	0.071	(1.8)	0.126	(3.2)
800	0.221	(5.6)	0.095	(2.4)	0.157	(4.0)
1000	0.280	(7.1)	0.126	(3.2)	0.197	(5.0)
1250	0.354	(9.0)	-	-	-	-
1500	0.433	(11.0)	-	-	-	-

<sup>1</sup> The base material shall have a minimum CTI of 100

<sup>2</sup> The coating shall comply with the requirements of Section 5.16

**Note:** Surge suppressors of the metal oxide varistor type are not considered to be acceptable overvoltage protection for equipment and circuits that operate in the primary circuit.

5.16.2 Dielectric Strength Testing on New Samples

5.16.2.1 The samples shall be conditioned by flexing them four times with a positive and negative deflection of 1/4 inch (5 mm) in the longitudinal, transverse and torsional directions.

5.16.2.2 A voltage of 1000 Volts A.C. plus twice rated voltage shall be applied for 1 minute without breakdown between adjacent printed circuits where the reduced spacings exist.

5.16.2.3 Equipment

Dielectric test equipment shall have an output that is essentially sinusoidal, with a voltage that is adjustable. The transformer shall have a 500 V•A or larger capacity unless provided with a voltmeter that directly indicates the output potential.

#### 5.16.2.4 Method

Each sample of coated board shall be blanketed with securely positioned aluminum foil or other similar conductive medium. The conductive medium shall completely cover the conductor pattern, except for the insulated lead wire and solder points.

**Note:** Test electrode removal prevents breakdown at the point of lead connection. An alternative to electrode removal is to insulate the test lead connection points sufficient to prevent breakdown from occurring in these locations. This alternative approach is likely to be taken when a conductive solution is used as a test electrode.

The test potential shall be applied between the common terminal of each sample and terminals A, B, and C in turn (with the conductive medium in place). The applied test voltage shall be increased from zero to the required value, at a substantially uniform rate that is consistent with the voltage being correctly indicated by the voltmeter used.

#### 5.16.3 Dielectric Strength Testing on Aged Samples

5.16.3.1 The same samples shall then be conditioned by maintaining them at  $194\text{ }^{\circ}\text{F} \pm 2\text{ }^{\circ}\text{F}$  ( $90\text{ }^{\circ}\text{C} \pm 1\text{ }^{\circ}\text{C}$ ) and then flexing them as specified in Section 5.16.2.1.

5.16.3.2 The samples shall then be subjected to the dielectric strength test in Section 5.16.2.2.

#### 5.16.4 Dielectric Strength Testing after Humidity Conditioning

5.16.4.1 The same samples shall then be conditioned by maintaining them at  $73\text{ }^{\circ}\text{F} \pm 2\text{ }^{\circ}\text{F}$  ( $23\text{ }^{\circ}\text{C} \pm 1\text{ }^{\circ}\text{C}$ ) and  $96 \pm 2$  percent relative humidity for 96 hours and then flexing them as specified in Section 5.16.2.1.

5.16.4.2 The samples shall then be subjected to the dielectric strength test in Section 5.16.2.2.

#### 5.16.5 Adhesion Acceptance Criteria

Following the test in Sections 5.16.2 through 5.16.4, the samples shall be investigated for adhesion of the coating to the board by scraping or cutting. The coating shall not flake.

### 5.17 Verification of capability of battery chargers (for diesel engine fire pump controllers only)

#### 5.17.1 Temperature and charge-capacity verification – Ampere-hour

When mounted as in normal service and loaded with two battery banks discharged over a 24 hour period to 1.75 V per cell at  $68\text{ }^{\circ}\text{F}$  ( $20\text{ }^{\circ}\text{C}$ ) (1.08 V per cell for NiCd), the exterior of a battery charger and components shall be placed in ambient air temperature between  $+50\text{ }^{\circ}\text{F}$  ( $+10\text{ }^{\circ}\text{C}$ ) and  $+104\text{ }^{\circ}\text{F}$  ( $+40\text{ }^{\circ}\text{C}$ ) that shall not vary by more than  $14\text{ }^{\circ}\text{F}$  ( $8\text{ }^{\circ}\text{C}$ ) during testing. The ambient air temperature shall be recorded during the last quarter of the test period by at least two temperature sensing means (i.e. thermometers or thermocouples) equally distributed around the equipment at about half its height and at a distance of about 3 ft (1 m) from the equipment. The temperature sensing means shall be protected against air currents, heat radiation and indicating errors due to rapid temperature changes.

The following test results shall be noted as being indicative of acceptable performance:

- a. Return 100 percent of the battery ampere-hour rating or reserve capacity within 24 hour without damage to the battery banks. The temperature of the battery electrolyte shall not exceed  $126\text{ }^{\circ}\text{F}$  ( $52\text{ }^{\circ}\text{C}$ );

- b. Automatically reduce the average charge current to not more than 500 mA when the battery banks reach full charge;
- c. Maintain the charge level in both battery banks.

During the above test, the ampere-hour input to the batteries shall be recorded using an ampere-hour recording meter. The test duration shall be between 24 hour and 48 hour, to verify that the battery charger complies with (b) and (c) above.

- d. The test above shall be repeated using two new discharged battery banks.

#### 5.17.2 Temperature and charge-capacity test - Reserve capacity

- a. Calculate the approximate ampere-hour rating of the battery to be charged by multiplying the reserve capacity by 25 and dividing by 60. For example, if the battery has a reserve capacity rating of 480 minutes, the approximate ampere-hour rating is equal to 200 ampere-hours.
- b. Determine the 20 hour discharge rate by dividing the approximate ampere-hour rating by 20. For example, the 20 hour rate for (a) above is 10 Amps.
- c. Discharge the battery until a terminal voltage of 1.75 V per cell (1.08 V per cell for NiCd) is measured using the 20 hour rate and record the ampere-hours of discharge in 24 hours.
- d. Connect the charger to the battery and measure the ampere-hours of charge put back into the battery.
- e. Verify that at least 100 percent of the ampere-hours taken out are replaced.
- f. Discharge the battery at 25 A to a terminal voltage of 1.75 V per cell (1.08 V per cell for NiCd), measured under load with the centre cell electrolyte temperature at 81 °F (27 °C) in 24 hours.
- g. The length of time to equal the rated service capacity of the battery shall be measured. The test duration shall be between 24 hours and 48 hours.

#### 5.17.3 Battery discharge test

Immediately following the test in 5.17.2 and with the batteries fully charged:

- a. The battery charger shall be disconnected from the power supply and the discharge current shall be measured in the output circuit of the charger, with the batteries connected;
- b. The total discharge current from both batteries shall not exceed 50 mA.

#### 5.17.4 Weak or missing battery(s) and loss of D.C. power test

The controller is required to have alarm and signal devices for certain fault conditions. Such conditions are battery failure, missing battery, battery charger failure and loss of D.C. power to controller. This test is conducted to verify these conditions, and will be conducted on both battery chargers installed in the diesel engine fire pump controller, and both battery sets.

- a. Connect a discharged battery or use voltage injection to simulate a battery with very low voltage and demonstrate audible alarm and visual signal on controller. Also, use voltage injection to simulate a battery with high voltage and record the voltage reading when high level visual alarm is illuminated.
- b. Disconnect charged battery and demonstrate audible alarm and visual signal on controller, for each battery set.
- c. Disconnect A.C. power to charger and demonstrate audible alarm and visual signal on controller, for each charger.
- d. Disconnect charger from battery and demonstrate audible alarm and visual signal on controller, for each charger.
- e. Disconnect D.C. power (both batteries) to controller and demonstrate audible alarm and visible signal on controller. Remove timer relay or standard power relay from control circuit and demonstrate audible alarm and visible signal on controller.

- f. Disconnect the A.C. (mains) power and then both batteries. The remote alarm contacts shall actuate to the alarm state.

#### 5.17.5 Continuous Output Current Test

At its maximum rated current output and its minimum rated input voltage, the charger must maintain minimum voltage levels of 110 percent of nominal. (i.e. 13.2V for 12 volt applications and 26.4V for 24 volt applications.)

This test will be conducted on one 12 Volt or 24 Volt charger. Adjust the charger input A.C. (mains) power to 90 percent of its rated nominal input voltage. The test will be performed on a resistive load since a discharged battery will suppress the voltage below its nominal voltage. Record input and output voltages and currents.

#### 5.17.6 Output Short Circuit Test

With the charger on (A.C. Power On), the battery connection leads shall be connected together. This shall not cause excessive current flow, heating, or damage to the charger. Also, this short circuit shall not influence the operation of the second charger.

This test will require two 12 Volt or 24 Volt chargers to be connected to a common A.C. supply. The A.C. Supply power shall be on, then the battery connection leads shall be connected together for 5 minutes. Current readings, temperature readings, and visual observations are to be recorded.

### 5.18 EMC

#### 5.18.1 Emission and immunity tests are required on final production controllers to verify compliance with the following specified environments:

- a. Emission compliance to Environment B. This environment relates to low-voltage public networks such as domestic/residential, commercial and light industrial locations/installations;
- b. Immunity compliance to Environment A. This environment relates to low-voltage non-public or industrial networks/locations/installations including highly disturbing sources;

These emission and immunity tests shall be carried out in accordance with the relevant EMC standards per Tables D.1, D.2 and D.3 in Appendix D; however, the manufacturer shall specify any additional necessary measures to verify the criteria of performance for the fire pump controller (i.e. dwell times).

#### 5.18.2 Emission Tests

##### 5.18.2.1 Conducted radio frequency emission test

Description of the test, the test method and the test set-up are given in CISPR 11. In the case of a range of fire pump controllers of different power ratings, it shall be sufficient to test two samples representing the highest and lowest power ratings of the range. The emission shall not exceed the levels given in CISPR 11, group 1, class B environment, as seen in Table D.1

**Note:** The addition of high-frequency common mode filtering in the main power connections may cause unacceptable reductions in motor starting torque, or render invalid the concept of unearthed or high impedance earthed distribution systems, as employed within process industries, with implications for system safety. If filters are not used for the above reasons, other means shall ensure that the emission levels are not exceeded.

##### 5.18.2.2 Radiated radio frequency emission test

Descriptions of the test, the test method and the test set-up are given in CISPR 11. In the case

of a range of fire pump controllers of different power ratings, it shall be sufficient to test two samples representing the highest and lowest power ratings of the range. The emission shall not exceed the levels given in CISPR 11, group 1, class B environment, as seen in Table D.1.

**Note:** In the USA, digital devices with power consumption less than 6 nW are exempt from RF emission tests.

### 5.18.3 Immunity Tests

#### 5.18.3.1 Electrostatic discharges

Fire pump controllers shall be tested using the methods of IEC 61000-4-2. The test levels of Table D.2 (referenced from Table 23 of IEC 60947-1) shall be used with 10 positive and 10 negative pulses applied to each selected point, the time interval between each successive single discharge being 1 second. Tests are not required on power terminals. Discharges shall be applied only to points that are accessible during normal usage. The fire pump controller shall comply with performance criterion 2 of Table D.3.

#### 5.18.3.2 Radiated radio-frequency electromagnetic fields

Fire pump controllers shall be tested using the methods of IEC 61000-4-3. The test level shall be as in Table D.2 (referenced from Table 23 of IEC 60947-1) for ranges 80 MHz to 1000 MHz and 1.4 GHz to 2 GHz. The fire pump controller shall comply with performance criterion 1 of Table D.3.

#### 5.18.3.3 Electrical fast transients/burst

Fire pump controllers shall be tested using the methods of IEC 61000-4-4. The test levels shall be as given in Table D.2 (referenced from Table 23 of IEC 60947-1) via the coupling/decoupling network. The test voltage shall be applied for 1 minute. Terminals for control and auxiliary circuits intended for the connection of conductors which extend more than 10 ft (3 m) shall be tested at 2,0 kV/5,0 kHz by means of the coupling clamp. The fire pump controller shall comply with performance criterion 2 of Table D.3.

#### 5.18.3.4 Surges

Fire pump controllers shall be tested using the methods of IEC 61000-4-5. The test level for power terminals shall be as given in Table D.2 (referenced from Table 23 of IEC 60947-1). The repetition rate shall be one per minute, with the number of pulses being five positive and five negative. The fire pump controller shall comply with performance criterion 2 of Table D.3.

#### 5.18.3.5 Conducted disturbances induced by radio-frequency fields

Fire pump controllers shall be tested using the methods of IEC 61000-4-6. The test level shall be as in Table D.2 (referenced from Table 23 of IEC 60947-1). The fire pump controller shall comply with performance criterion 1 of Table D.3.

#### 5.18.3.6 Harmonics and commutation notches

No test requirements.

**Note:** Future tests are under consideration by IEC 61000-6-2.



**5.18.3.7 Voltage dips and short-time interruptions**

Fire pump controllers shall be tested using the methods of IEC 61000-4-11 (2004). The test levels shall be as given in Table D.2 (referenced from Table 23 of IEC 60947-1). The fire pump controller shall comply with performance criterion 2 of Table D.3.

## 6 MANUFACTURER'S REQUIREMENTS

### 6.1 Demonstrated Quality Control Program

6.1.1 A quality assurance program is required to assure that subsequent products produced by the manufacturer shall present the same quality and reliability as the specific products examined. Design quality, conformance to design, and performance are the areas of primary concern.

- Design quality is determined during the examination and tests and may be documented in the certification report.
- Continued conformance to this standard is verified by the certifiers surveillance program.
- Quality of performance is determined by field performance and by periodic re-examination and testing.

6.1.2 The manufacturer shall demonstrate a quality assurance program which specifies controls for at least the following areas:

- existence of corporate quality assurance guidelines;
- incoming quality assurance, including testing;
- in-process quality assurance, including testing;
- final inspection and tests;
- equipment calibration;
- drawing and change control;
- packaging and shipping; and
- handling and disposition of non-conforming materials.

#### 6.1.3 Documentation/Manual

There should be an authoritative collection of procedures/policies. It should provide an accurate description of the quality management system while serving as a permanent reference for implementation and maintenance of that system. The system should require that sufficient records are maintained to demonstrate achievement of the required quality and verify operation of the quality system.

#### 6.1.4 Records

To assure adequate traceability of materials and products, the manufacturer shall maintain a record of all quality assurance tests performed, for a minimum period of two years from the date of manufacture.

#### 6.1.5 Drawing and Change Control

- The manufacturer shall establish a system of product configuration control that shall allow no unauthorized changes to the product. Changes to critical documents, identified in the certification report, may be required to be reported to, and authorized by the certification agency prior to implementation for production.
- Records of all revisions to all certified products shall be maintained.

## 6.2 Surveillance Audit

- 6.2.1 An audit of the manufacturing facility may be part of the certification agencies surveillance requirements to verify implementation of the quality assurance program. Its purpose is to determine that the manufacturer's equipment, procedures, and quality program are maintained to insure a uniform product consistent with that which was tested and certified.
- 6.2.2 Certified products or services shall be produced or provided at, or provided from, location(s) disclosed as part of the certification examination. Manufacture of products bearing a certification mark is not permitted at any other location prior to disclosure to the certification agency.

## 6.3 Product Modifications

The manufacturer shall notify and receive authorization from the certification agency for changes in product construction, design, components, raw materials, physical characteristics, coatings, component formulation or quality assurance procedures prior to implementation of such changes.

## 6.4 Manufacturing and Routine Production Tests

The manufacturer shall perform routine production tests as specified below on 100 percent of all Certified fire pump controllers prior to shipment. Routine tests shall be made on each individual fire pump controller in the manufacturing facility. Routine tests for fire pump controllers include the verification of:

- a. operating limits, performance characteristics and functionality;
- b. dielectric properties.

### 6.4.1 Verification of operating limits

It shall be verified that the controller operates according to the requirements of Section 5.10.1 of this standard, and the following.

### 6.4.2 Inspection of the assembly including inspection of wiring and electrical operation test.

- a. The effectiveness of mechanical actuating elements, interlocks, locks, etc., shall be checked. The conductors and cables shall be checked for proper laying and the devices for proper mounting. A visual inspection is also necessary to ensure that the prescribed degree of protection, creepage distances and clearances are maintained.
- b. The connections, especially screwed and bolted connections, shall be checked for adequate contact.
- c. It shall be verified that the information and markings specified in Section 3.3 of this standard are complete, and that the assembly corresponds to these. In addition, the conformity of the assembly to the circuit and wiring diagrams, technical data, etc., provided by the manufacturer shall be checked.
- d. Inspect wiring and conduct electrical functioning test on all interlocks, control functions and alarms.
- e. Upon final installation, verification of proper wiring connections and electrical functioning tests shall be repeated as necessary and agreed upon between manufacturer and user

### 6.4.3 Verification of dielectric properties

For the verification of power frequency withstand voltage, a dielectric test on the controller shall be

conducted using an essentially sinusoidal test voltage in accordance with Table 6.4.3 below. The test voltage shall be applied for 5 seconds to the incoming supply terminals, with the FPC-short circuit protective devices and disconnect (isolation switch) in the open and closed position. Dielectric integrity shall be verified between all poles and the frame and between each pole. Tests shall be conducted with and without electronic boards connected to the system.

Table 6.4.3 Dielectric Test Voltage Corresponding to the Rated Insulation Voltage

<i>Rated insulation voltage <math>U_i</math> (line to line) Volts</i>	<i>A.C. test voltage (r.m.s.) Volts</i>	<i>D.C. test voltage<sup>b,c</sup> Volts</i>
<b><math>U_i \leq 60</math></b>	<b>1,000</b>	<b>1,415</b>
<b><math>60 &lt; U_i \leq 300</math></b>	<b>1,500</b>	<b>2,120</b>
<b><math>300 &lt; U_i \leq 690</math></b>	<b>1,890</b>	<b>2,670</b>
<b><math>690 &lt; U_i \leq 800</math></b>	<b>2,000</b>	<b>2,830</b>
<b><math>800 &lt; U_i \leq 1,000</math></b>	<b>2,200</b>	<b>3,110</b>
<b><math>1,000 &lt; U_i \leq 1,500^a</math></b>	-	<b>3,820</b>

- a. For D.C. only
- b. Test Voltages based on 4.1.2.3.1 of IEC 60664-1.
- c. A direct current test voltage may be used only if an alternating test voltage cannot be applied. See also 8.3.3.4.1, item, 3) b) ii) of IEC 60947-1.

The dielectric voltage withstand test per UL 508, and as presented in Section 5.6 of this standard, is also an acceptable method of verifying dielectric properties.

#### 6.4.4 Manufacturer's Field Support Responsibilities

The controller manufacturer shall be responsible for the performance of the controller even after final installation, and shall respond in a timely manner to all matters concerning improper or failed performance of the controller in the field. The manufacturer shall work with the assigned the certification agency's engineering representatives to rectify any and all field problems related to the controller, and send qualified field technicians/engineers into the field to repair defective units, as necessary. The manufacturer shall not rely upon or expect the certification agency's field personnel to diagnose and correct any problems identified with a controller in the field. Any failure of the manufacturer to conform to these field support requirements shall void the certification of all controllers produced by same manufacturer.

## 7 BIBLIOGRAPHY

ISO/IEC 17025, *General Requirements for the Competence of Testing and Calibration Laboratories*.

### Appendix A: Tables

Table A.1: Diesel fire pump controller terminal numbering

<i>Terminal Number</i>	<i>Function</i>
1	Fuel/water solenoid, if used
2	Crank terminate speed switch
3	Overspeed switch
4	Lubricating oil pressure low switch
5	Engine coolant temperature high switch
6	Battery 1 anode
7	Engine alternator, if used
8	Battery 2 anode
9	Crank on battery 1
10	Crank on battery 2
11	Battery cathodes
12	Shutdown solenoid, if used
301	ECM B - ECM (Electronic Control Module) selector switch is in alternate ECM position, if used
302	FIM - Fuel injection malfunction, if used
303	ECM Warning
304	ECM Failure
305 - 309	Reserved for ECM Engine future use
310	Raw water high inlet temperature
311	Clogged raw water coolant loop strainer
312	Low engine temperature

Table A.2: Wire bending space at field wiring terminals<sup>a</sup>

<i>Size of wire</i>		<i>Minimum bending space, terminal to wall, Wires per terminal</i>					
<i>AWG or kcmil</i>	<i>Nominal (mm<sup>2</sup>)</i>	<i>1</i>		<i>2</i>		<i>3</i>	
		<i>in.</i>	<i>(mm)</i>	<i>in.</i>	<i>(mm)</i>	<i>in.</i>	<i>(mm)</i>
14 - 9	(2.5 - 6)	-	-	-	-	-	-
8 - 6	(10 - 16)	1.5	(38)	-	-	-	-
4 - 3	(25)	2.0	(51)	-	-	-	-
2	(35)	2.5	(64)	-	-	-	-
1	(40)	3.0	(76)	-	-	-	-
1/0	(50)	5.0	(127)	5.0	(127)	7.0	(178)
2/0	(70)	6.0	(152)	6.0	(152)	7.5	(191)
3/0	(95)	7.0	(178)	7.0	(178)	8.0	(203)
4/0	(105)	7.0	(178)	7.0	(178)	8.5	(216)
250	(120)	8.0	(203)	8.0	(203)	9.0	(229)
300	(150)	10.0	(254)	10.0	(254)	11.0	(279)
350	(185)	12.0	(305)	12.0	(305)	13.0	(330)
400	(205)	12.0	(305)	12.0	(305)	14.0	(356)
500	(240)	12.0	(305)	12.0	(305)	15.0	(381)
600	(300)	14.0	(356)	16.0	(406)	18.0	(457)
700	(350)	14.0	(356)	16.0	(406)	20.0	(508)
750 - 800	(380 - 400)	18.0	(457)	19.0	(483)	22.0	(559)
900	(450)	18.0	(457)	19.0	(483)	24.0	(610)

a. Equipment intended for installation in Canada is permitted to comply with CSA 22.2 No. 0.12 Wire Bending Space

Table A.3: Minimum acceptable spacings

Potential involved volts rms A.C. or D.C.		Minimum spacings, inch (mm)											
		General equipment						Devices having limited rating					
		51 - 150		151 - 300		301 - 600		51 - 150		151 - 300		301 - 600	
Between any uninsulated live part and an uninsulated live part of opposite polarity, uninsulated grounded part other than the enclosure, or exposed metal part	Through air or oil	1/8 <sup>a</sup>	(3.0)	1/4	(6.3)	3/8	(9.4)	1/16 <sup>a</sup>	(1.5)	1/16 <sup>a</sup>	(1.5)	3/16 <sup>a</sup>	(4.6)
	Over surface	1/4	(6.3)	3/8	(9.4)	1/2	(12.7)	1/8 <sup>a</sup>	(3.0)	1/8 <sup>a</sup>	(3.0)	3/8	(9.4)
Between any uninsulated live part and the walls of a metal enclosure including fittings for conduit or armoured cable <sup>b</sup>	Shortest distance	1/2	(12.7)	1/2	(12.7)	1/2	(12.7)	1/4	(6.3)	1/4	(6.3)	1/2	(12.7)

1. A slot, groove, or the like, 0.013 in. (0.33 mm) wide or less in the contour of insulating material is to be disregarded.
2. An air space of 0.013 in. (0.33 mm) or less between a live part and an insulating surface is to be disregarded for the purpose of measuring over surface spacings.
  - a. The spacing between field wiring terminals of opposite polarity and the spacing between a field wiring terminal and a grounded dead metal part shall be at least 1/4 in. (6.3 mm) if short circuiting or grounding of such terminals may result from projecting strands of wire. For circuits involving no potential greater than 50V rms A.C. or D.C., spacings at field wiring terminals may be 1/8 in. (3.0 mm) through air and 1/4 in. (6.3 mm) over surface.
  - b. For the purpose of this requirement, a metal piece attached to the enclosure is considered to be a part of the enclosure if deformation of the enclosure is likely to reduce the spacings between the metal piece and uninsulated live parts.

Table A.4: Minimum spacings between traces of opposite polarity on printed wiring boards

Volts, <sup>a</sup> c rms or D.C.	Transient voltage no limited				Transient voltage limited <sup>b</sup>			
	Coated <sup>c</sup>		Uncoated		Coated <sup>c</sup>		Uncoated	
	in.	(mm)	in.	(mm)	in.	(mm)	in.	(mm)
10	0.0032	(0.08)	0.0158	(0.40)	0.001	(0.025)	0.0016	(0.04)
12.5	0.0035	(0.09)	0.0165	(0.42)	0.001	(0.025)	0.0016	(0.04)
16	0.0039	(0.10)	0.0177	(0.45)	0.001	(0.025)	0.0016	(0.04)
20	0.0043	(0.11)	0.0189	(0.48)	0.001	(0.025)	0.0016	(0.04)
25	0.0049	(0.125)	0.0197	(0.50)	0.001	(0.025)	0.0016	(0.04)
32	0.0055	(0.14)	0.0209	(0.53)	0.001	(0.025)	0.0016	(0.04)
40	0.0063	(0.16)	0.0315	(0.8)	0.001	(0.025)	0.0016	(0.04)
50	0.0071	(0.18)	0.0335	(0.85)	0.001	(0.025)	0.0016	(0.04)
100	0.0098	(0.25)	0.0394	(1.0)	0.0039	(0.10)	0.0063	(0.16)
125	0.0110	(0.28)	0.0413	(1.05)	0.0063	(0.16)	0.0098	(0.25)
160	0.0126	(0.32)	0.0433	(1.1)	0.0098	(0.25)	0.0016	(0.40)
200	0.0165	(0.42)	0.0551	(1.4)	0.0158	(0.40)	0.0248	(0.63)
250	0.0221	(0.56)	0.0709	(1.8)	0.0221	(0.56)	0.0394	(1.0)
320	0.0295	(0.75)	0.0866	(2.2)	0.0295	(0.75)	0.0630	(1.60)
400	0.0394	(1.0)	0.1102	(2.8)	0.0394	(1.0)	0.0787	(2.0)
500	0.0512	(1.3)	0.1417	(3.6)	0.0512	(1.3)	0.0984	(2.5)
630	0.0709	(1.8)	0.1772	(4.5)	0.0709	(1.8)	0.126	(3.2)
800	0.0945	(2.4)	0.2205	(5.6)	0.0945	(2.4)	0.1575	(4.0)
1 000	0.126	(3.2)	0.2795	(7.1)	0.126	(3.2)	0.1968	(5.0)
1 250	0.1654	(4.2)	0.3543	(9.0)	-	-	-	-
1 600	0.2205	(5.6)	0.4331	(11.0)	-	-	-	-
2 000	0.2953	(7.5)	0.5512	(14.0)	-	-	-	-
2 500	0.3937	(10.0)	0.7087	(18.0)	-	-	-	-
3 200	0.4921	(12.5)	0.8661	(22.0)	-	-	-	-
4 000	0.6299	(16.0)	1.1024	(28.0)	-	-	-	-
5 000	0.7874	(20.0)	1.4173	(36.0)	-	-	-	-
6 300	0.9842	(25.0)	1.7716	(45.0)	-	-	-	-
8 000	1.2598	(32.0)	2.2047	(56.0)	-	-	-	-

1. Linear interpolation of values is permitted.
  - a. Between the traces where spacing is measured.
  - b. The maximum recurring peak voltage shall not exceed the applicable value specified in Table 6.3 of the Standard for Insulation Coordination Including Clearances and creepage Distances for Electrical Equipment, UL 840, when tested in accordance with the Recurring Peak Voltage Determination Test, Section 9 in UL 840, except a coated printed wiring board is tested in the uncoated condition.
  - c. The coating shall comply with the requirements of UL 840 Section 15 or CSA C22.2 No. 14 2005, Section 6.2 as detailed in Section 5.16, Printed Circuit Board Coating Performance Test, of this standard.

Table A.5: Generic Material Acceptable as a Barrier (See Clause 4.1.6.5)

<i>Material</i>	<i>Minimum barrier thickness</i>		<i>Minimum barrier thickness when used in addition to not less than one-half of the required through air spacing</i>		<i>Insulation Class Degree</i>	
	<i>in.</i>	<i>(mm)</i>	<i>in.</i>	<i>(mm)</i>	<i>°F</i>	<i>(°C)</i>
Electrical Grade Paper	0.026	(0.66)	0.013	(0.33)	220	(105)
Impregnated Rag Paper	0.020	(0.51)	0.010	(0.253)	220	(105)
Acetate Cloth	0.052	(1.32)	0.026	(0.66)	220	(105)
Acetate Film	0.017	(0.44)	0.009	(0.22)	220	(105)
Glassine	0.017	(0.44)	0.009	(0.22)	220	(105)
Varnished Cambric	0.016	(0.4)	0.008	(0.198)	220	(105)
Polyamide	0.013	(0.33)	0.007	(0.165)	265	(130)
Polyethylene Terephthalate Film	0.013	(0.33)	0.007	(0.165)	265	(130)
Polyester Film	0.013	(0.33)	0.007	(0.165)	265	(130)
Polybutylene Terephthalate	0.013	(0.33)	0.007	(0.165)	265	(130)
Silicon Impregnated Glass Cloth	0.026	(0.66)	0.013	(0.33)	355	(180)
Aramid Paper	0.013	(0.33)	0.006	(0.163)	428	(220)
PTFE Sheet	0.009	(0.22)	0.004	(0.11)	482	(250)
Polyimide	0.004	(0.11)	0.002	(0.055)	482	(250)



Table A.6: Full-load motor-running currents in amperes corresponding to various A.C. kilowatt and horsepower ratings

HP	(kW)	110 - 120V		200V		208V		220 - 240V <sup>a</sup>		380 - 415V <sup>b,c</sup>		440 - 480V		550 - 600V	
		1 phase	3 phase	1 phase	3 phase	1 phase	3 phase	1 phase	3 phase	1 phase	3 phase	1 phase	3 phase	1 phase	3 phase
1/2	(0.37)	9.8	4.4	5.6	2.5	5.4	2.4	4.9	2.2	3.0	1.3	2.5	1.1	2.0	0.9
3/4	(0.56)	13.8	6.4	7.9	3.7	7.6	3.5	6.9	3.2	4.2	1.9	3.5	1.6	2.8	1.3
1	(0.75)	16.0	8.4	9.2	4.8	8.8	4.6	8.0	4.2	4.8	2.5	4.0	2.1	3.2	1.7
1-1/2	(1.1)	20.0	12.0	11.5	6.9	11.0	6.6	10.0	6.0	6.1	3.6	5.0	3.0	4.0	2.4
2	(1.5)	24.0	13.6	13.8	7.8	13.2	7.5	12.0	6.8	7.3	4.1	6.0	3.4	4.8	2.7
3	(2.2)	34.0	19.2	19.6	11.0	18.7	10.6	17.0	9.6	10.3	5.8	8.5	4.8	6.8	3.9
5	(3.7)	56.0	30.4	32.2	17.5	30.8	16.7	28.0	15.2	16.9	9.2	14.0	7.6	11.2	6.1
7-1/2	(5.6)	80.0	44.0	46.0	25.3	44.0	24.2	40.0	22.0	25.4	13.3	21.0	11.0	16.0	9.0
10	(7.5)	100.0	56.0	57.5	32.2	55.0	30.8	50.0	28.0	31.5	16.9	26.0	14.0	20.0	11.0
15	(11.2)	135	84.0	-	48.3	-	46.2	68.0	42.0	41.1	25.4	34.0	21.0	27.0	17.0
20	(15)	-	108	-	62.1	-	59.4	88.0	54.0	53.2	32.7	44.0	27.0	35.0	22.0
25	(18.6)	-	136	-	78.2	-	74.8	110	68.0	66.6	41.1	55.0	34.0	44.0	27.0
30	(22.4)	-	160	-	92.0	-	88.0	136	80.0	82.3	48.4	68.0	40.0	54.0	32.0
40	(30)	-	208	-	120	-	114	176	104	106	62.9	88.0	52.0	70.0	41.0
50	(37.3)	-	260	-	150	-	143	216	130	131	78.7	108	65.0	86.0	52.0
60	(45)	-	-	-	177	-	169	-	154	-	93.2	-	77.0	-	62.0
75	(56)	-	-	-	221	-	211	-	192	-	116	-	96.0	-	77.0
100	(74.6)	-	-	-	285	-	273	-	248	-	150	-	124	-	99.0
125	(93.2)	-	-	-	359	-	343	-	312	-	189	-	156	-	125
150	(112)	-	-	-	414	-	396	-	360	-	218	-	180	-	144
200	(149)	-	-	-	552	-	528	-	480	-	290	-	240	-	192
250	(186.4)	-	-	-	-	-	-	-	604	-	365	-	302	-	242
300	(223.7)	-	-	-	-	-	-	-	722	-	437	-	361	-	289
350	(261)	-	-	-	-	-	-	-	828	-	501	-	414	-	336
400	(298.3)	-	-	-	-	-	-	-	954	-	577	-	477	-	382
450	(335.6)	-	-	-	-	-	-	-	1030	-	623	-	515	-	412
500	(373)	-	-	-	-	-	-	-	1180	-	714	-	590	-	472

- a To obtain full-load currents for 265 and 277V motors, decrease corresponding 220 - 240V ratings by 13 and 17 percent, respectively.
- b These voltages are not used in North America, and are provided for reference only.
- c Current values shown are applicable for NEMA Design B motors with starting codes F and G only. For all other motors further investigation is required.

Table A.7: AWG to Metric Conversion Chart

<i>AWG Number</i>	<i>Diameter, in.</i>	<i>Diameter, mm</i>	<i>Area, mm<sup>2</sup></i>
6/0 = 000000	0.580	14.73	170.30
5/0 = 00000	0.517	13.12	135.10
4/0 = 0000	0.460	11.7	107
3/0 = 000	0.410	10.4	85.0
2/0 = 00	0.365	9.26	67.4
1/0 = 0	0.325	8.25	53.5
1	0.289	7.35	42.4
2	0.258	6.54	33.6
3	0.229	5.83	26.7
4	0.204	5.19	21.1
5	0.182	4.62	16.8
6	0.162	4.11	13.3
7	0.144	3.66	10.5
8	0.128	3.26	8.36
9	0.114	2.91	6.63
10	0.102	2.59	5.26
11	0.0907	2.30	4.17
12	0.0808	2.05	3.31
13	0.0720	1.83	2.62
14	0.0641	1.63	2.08
15	0.0571	1.45	1.65
16	0.0508	1.29	1.31
17	0.0453	1.15	1.04
18	0.0403	1.02	0.823
19	0.0359	0.912	0.653
20	0.0320	0.812	0.518
21	0.0285	0.723	0.410
22	0.0253	0.644	0.326
23	0.0226	0.573	0.258
24	0.0201	0.511	0.205
25	0.0179	0.455	0.162
26	0.0159	0.405	0.129
27	0.0142	0.361	0.102
28	0.0126	0.321	0.0810
29	0.0113	0.286	0.0642
30	0.0100	0.255	0.0509
31	0.00893	0.227	0.0404
32	0.00795	0.202	0.0320
33	0.00708	0.180	0.0254
34	0.00631	0.160	0.0201
35	0.00562	0.143	0.0160
36	0.00500	0.127	0.0127
37	0.00445	0.113	0.0100
38	0.00397	0.101	0.00797
39	0.00353	0.0897	0.00632
40	0.00314	0.0799	0.00501

1. This table gives closest equivalent size cross references between metric and American wire sizes. In Europe, wire sizes are expressed in cross sectional area in mm<sup>2</sup> and also as the number of strands of wires of a diameter expressed in mm. For example 7/0.2 means 7 strands of wire each 0.2 mm diameter. The example has a cross sectional area of 0.22 mm<sup>2</sup>. In America, the most common system is the AWG numbering scheme, where the numbers are applied not only to individual strands but also to equivalent size bunches of smaller strands. For example, 24AWG could be made of 1 strand of 24AWG wire (1/24) or 7 strands of 32AWG wire (7/32)

Table A.8: Size of bonding, equipment grounding, grounding electrode conductors, and ground busa

Maximum Ampere Rating <sup>b</sup>	Size of Equipment Grounding or Bonding Conductor, Minimum				Size of Grounding Electrode Conductor, Minimum				Size of Main Bonding Jumper, Minimum			
	Copper		Aluminum		Copper		Aluminum <sup>f</sup>		Copper		Aluminum <sup>f</sup>	
	mm <sup>2</sup>	(AWG or kcmil) <sup>g</sup>	mm <sup>2</sup>	(AWG or kcmil) <sup>g</sup>	mm <sup>2</sup>	(AWG or kcmil)	mm <sup>2</sup>	(AWG or kcmil)	mm <sup>2</sup>	(AWG or kcmil)	mm <sup>2</sup>	(AWG or kcmil)
15	2.1 <sup>c</sup>	(14 <sup>c</sup> )	3.3 <sup>c</sup>	(12 <sup>c</sup> )	-	-	-	-	-	-	-	-
20	[2.1] <sup>g</sup> 3.3 <sup>c</sup>	([14] <sup>g</sup> 12 <sup>c</sup> )	[3.3] <sup>g</sup> 5.3 <sup>c</sup>	([12] <sup>g</sup> 10 <sup>c</sup> )	-	-	-	-	-	-	-	-
30	[3.3] <sup>g</sup> 5.3 <sup>c</sup>	([12] <sup>g</sup> 10 <sup>c</sup> )	[5.3] <sup>g</sup> 8.4 <sup>c</sup>	([10] <sup>g</sup> 8 <sup>c</sup> )	-	-	-	-	-	-	-	-
40	5.3 <sup>c</sup>	(10 <sup>c</sup> )	8.4 <sup>c</sup>	(8 <sup>c</sup> )	-	-	-	-	-	-	-	-
60	5.3 <sup>c</sup>	(10 <sup>c</sup> )	8.4 <sup>c</sup>	(8 <sup>c</sup> )	-	-	-	-	-	-	-	-
90	8.4	(8)	13.3	(6)	8.4	(8)	13.3	(6)	8.4	(8)	13.3	(6)
100	8.4	(8)	13.3	(6)	13.3	(6)	21.2	(4)	13.3	(6)	21.2	(4)
150	13.3	(6)	21.2	(4)	13.3	(6)	21.2	(4)	13.3	(6)	21.2	(4)
200	13.3	(6)	21.2	(4)	21.2	(4)	33.6	(2)	21.2	(4)	33.6	(2)
300	21.2	(4)	33.6	(2)	33.6	(2)	53.5	(1/0)	33.6	(2)	53.5	(1/0)
400	26.7	(3)	42.4	(1)	53.5 <sup>d</sup>	(1/0 <sup>d</sup> )	85 <sup>d</sup>	(3/0 <sup>d</sup> )	53.5 <sup>d</sup>	(1/0 <sup>d</sup> )	85 <sup>d</sup>	(3/0 <sup>d</sup> )
500	33.6	(2)	53.5	(1/0)	53.5	(1/0)	85	(3/0)	53.5	(1/0)	85	(3/0)
600	42.4	(1)	67.4	(2/0)	67.4	(2/0)	107	(4/0)	67.4	(2/0)	107	(4/0)
800	53.5	(1/0)	85	(3/0)	67.4	(2/0)	107	(4/0)	67.4	(2/0)	107	(4/0)
1000	67.4	(2/0)	107	(4/0)	85	(3/0)	127	(250)	85	(3/0)	127	(250)
1200	85	(3/0)	127	(250)	85	(3/0)	127	(250)	127 <sup>e</sup>	(250 <sup>e</sup> )	127	(250)
1600	107	(4/0)	177	(350)	85	(3/0)	127	(250)	152 <sup>e</sup>	(300 <sup>e</sup> )	203 <sup>e</sup>	(400 <sup>e</sup> )
2000	127	(250)	203	(400)	85	(3/0)	127	(250)	203 <sup>e</sup>	(400 <sup>e</sup> )	253 <sup>e</sup>	(500 <sup>e</sup> )
2500	177	(350)	[253] <sup>g</sup> 304	([500] <sup>g</sup> 600)	85	(3/0)	127	(250)	253 <sup>e</sup>	(500 <sup>e</sup> )	355 <sup>e</sup>	(700 <sup>e</sup> )
3000	203	(400)	304	(600)	85	(3/0)	127	(250)	304 <sup>e</sup>	(600 <sup>e</sup> )	380 <sup>e</sup>	(750 <sup>e</sup> )
4000	253	(500)	405	(800)	85	(3/0)	127	(250)	380 <sup>e</sup>	(750 <sup>e</sup> )	507 <sup>e</sup>	(1000 <sup>e</sup> )
5000	355	(700)	[507] <sup>g</sup> 608	([1000] <sup>g</sup> 1200)	85	(3/0)	127	(250)	456	(900)	633	(1250)
6000	405	(800)	[633] <sup>g</sup> 608	([1250] <sup>g</sup> 1200)	85	(3/0)	127	(250)	633	(1250)	760	(1500)

- a. See Table 25 for equivalent area of bus. Size of ground bus to be in accordance with Table 25 based on columns 1 - 3 of Table 24
- b. Maximum ampere rating of centre or circuit overcurrent device ahead of equipment-grounding means.
- c. Values are applicable to equipment-grounding conductors only. (Note c does not apply in Canada.)
- d. If the ampere rating is 400 and the wire terminal connectors for the main service conductors are rated for two No. 3/0 AWG (85 mm<sup>2</sup>) copper conductors or two 250 kcmil (127 mm<sup>2</sup>) aluminum conductors but will not accept a 600 kcmil (304 mm<sup>2</sup>) conductor, these values may be reduced to 2 AWG (33.6 mm<sup>2</sup>) copper or 1/0 AWG (53.5 mm<sup>2</sup>) aluminum.
- e. The cross-section may be reduced to 12.5 percent of the total cross-section of the largest main service conductor of the same material (copper or aluminum) for any phase on centres rated 1200A and over. This applies when the cross-section of the service conductors is limited by the wire terminal connectors provided.
- f. Aluminum is not permitted in Canada.
- g. In Canada, the values in brackets [xx] apply.

Table A.9: Ampacities of insulated conductors

<i>Conductor size</i>		<i>Ampacity</i>	<i>Conductor size</i>		<i>Ampacity</i>
<i>AWG or kcmil</i>	<i>(mm<sup>2</sup>)</i>		<i>AWG or kcmil</i>	<i>(mm<sup>2</sup>)</i>	
18	(0.82)	7	3/0	(85.0)	260 280
16	(1.3)	10	4/0	(107.2)	300 327
14	(2.1)	17 15	250	(127)	340 361
12	(3.3)	21 20	300	(152)	375 408
10	(5.3)	35 30	350	(177)	420 450
8	(8.4)	60 60	400	(203)	455 488
6	(13.3)	80 85	500	(253)	515 560
4	(21.2)	105 115	600	(304)	575
3	(26.7)	120 132	700	(354)	630
2	(33.6)	140 153	750	(380)	655
1	(42.4)	165 180	800	(406)	680
1/0	(53.5)	195 204	1000	(508)	780
2/0	(67.4)	225 243			

- 1 For multiple-conductors of the same size 1/0 AWG or larger at a terminal, the ampacity is equal to the value in the table for that conductor multiplied by the number of conductors that the terminal will accommodate.
- 2 For bundling three conductors, values shall be derated by 0.65.
- 3 For bundling four to six conductors, values shall be derated by 0.52.
- 4 For bundling seven to nine conductors, values shall be derated by 0.455.

Table A.10: Temperature Rise Test Limits - Materials and components

Materials and components		$\Delta$ °F	( $\Delta$ °C)
1.	Knife-switch blades and contact jaws	54	(30)
2.	Fuse clip when tested with a dummy fuse that represents a fuse intended to provide branch-circuit protection	54	(30)
3.	Fuse clip when tested with a fuse intended to provide branch-circuit protection <sup>o</sup>	153	(85)
4.	Rubber- or thermoplastic-insulated conductors	a	a
5.	Field-wiring terminals <sup>c, k, i</sup>		
	Equipment marked 140 °F (60 °C) or 140/167 °F (60/75 °C) supply wires	90	(50)
	Equipment marked 167 °F (75 °C) supply wires	117	(65)
6.	Buses and connecting straps or bars <sup>d</sup>	l	l
7.	Contacts		
	Solid and built-up silver, silver alloy, and silver faced	e	e
	All other metals	117	(65)
8.	Insulation systems		
	Class 105 insulation system <sup>f</sup>		
	Thermocouple method	117	(65)
	Resistance method	126	(70)
	Class 105(A) insulation systems on single-layer series coil with exposed surfaces either uninsulated or enameled, thermocouple method		
	Class 120(E) insulation systems <sup>f, r</sup>		
	Thermocouple method	135	(75)
	Resistance method	171	(95)
	Class 130(B) insulation systems <sup>f, r</sup>		
	Thermocouple method	153	(85)
	Resistance method	171	(95)
	Class 155(F) insulation systems <sup>f, r</sup>		
	Thermocouple method	198	(110)
	Resistance method	207	(115)
	Class 180(H) insulation systems <sup>f, r</sup>		
	Thermocouple method	225	(125)
	Resistance method	243	(135)
	Class 200(N) insulation systems <sup>f, r</sup>		
	Thermocouple method	252	(140)
	Resistance method	270	(150)
	Class 220(B) insulation systems <sup>f, r</sup>		
	Thermocouple method	279	(155)
	Resistance method	297	(165)
9.	Insulating materials <sup>b</sup>	p	p
10.	In the issuing air, 1 in. (25.4 mm) above the enclosure	315	(175)
11.	On the embedding material of a resistor, a rheostat, and a wall-mounted dimmer with an embedded resistive element	540	(300)
12.	On the embedding material of a rheostatic dimmer having embedded resistive conductors, and arranged for mounting on a switchboard, or in a noncombustible frame	630	(350)
13.	On bare resistor material, thermocouple method	675	(375)
14.	Capacitor	g	g
15.	Power switching semiconductors	m	m
16.	Printed-wiring boards	n	n
17.	Any component or material not specifically identified in 1 – 16	q	q
a.	For insulated conductors the maximum temperature rise shall not exceed the maximum operating temperature specified for the wire in question minus an assumed ambient (room) temperature of 104 °F (40 °C).		
b.	For compounds which have been investigated for particular temperature ratings, the maximum temperature rise shall not exceed the temperature rating minus an assumed ambient of 104 °F (40 °C).		

c.	The temperature on a wiring terminal or lug is measured at the point most likely to be contacted by the insulation of a conductor installed as in actual service.
d.	The limit does not apply to connections to a source of heat, such as a resistor and a current element of an overload relay.
e.	Temperature limited by the temperature limitations on the material for adjacent parts. There shall be no structural deterioration of the contact assembly, loosening of parts, cracking or flaking of materials, loss of temper of spring, annealing of parts, or other visible damage.
f.	See 43.19 – 43.25.
g.	For a capacitor, the maximum temperature rise is the marked temperature limit of the capacitor minus an assumed ambient temperature of 104 °F (40 °C).
h.	Deleted
i.	When the rise is 90 °F (50 °C) or less and an aluminum bodied connector is used or aluminum wire is intended, the connector shall be marked AL7CU or AL9CU; when the terminal temperature rise exceeds 90 °F (50 °C) and does not exceed 150 °F (65 °C), the connector shall be marked AL9CU.
j.	Deleted
k.	See 63.3.
l.	The limit applies only to bus bars and connecting straps used for distribution of power to industrial control devices. The limit does not apply to short pieces of copper located within industrial control devices and used for the support of stationary contact assemblies or factory or field wiring terminations. The maximum temperature rises for this type of construction are determined by the temperature limitations on the support material, adjacent part material, or 212 °F (100 °C) temperature rise on the copper material, whichever is lower. There shall be no structural deterioration of the assembly, loosening of parts, cracking or flaking of material, loss of temper of spring, annealing of parts, or other visible damage.
m.	The maximum temperature rise on the case is the maximum case temperature for the applied power dissipation recommended by the semiconductor manufacturer minus an assumed ambient of 104 °F (40 °C).
n.	The maximum temperature rise of the printed-wiring board is the operating temperature of the board minus an assumed ambient of 104 °F (40 °C).
o.	See 63.23.
p.	See Tables 15.2 and 37.1.
q.	The maximum temperature rise of any component shall not exceed the temperature limit of the component minus an assumed ambient temperature of 104 °F (40 °C).
r.	The insulation system shall meet the requirements of UL 1446, Standard for Systems of Insulating Materials – General.

Table A.11: Temperature Rise Test Limits - Surface

<i>Surface</i>		<i>Δ °F</i>	<i>(Δ °C)</i>
1.	Inaccessible parts of the enclosure (for example, the back of wall mounting enclosures) or accessible surfaces not subject to casual contact (for example, without parts intended to be touched) <sup>a, b</sup>	122	(50)
2.	Accessible parts of the enclosure subject to casual contact (for example, enclosure surfaces containing parts intended to be touched)		
	Nonmetallic <sup>b</sup>	104	(40)
	Metal <sup>b</sup>	86	(30)
3.	Parts intended to be touched (for example, operating knobs or handles of power switches and similar parts)		
	Nonmetallic	77	(25)
	Metal	59	(15)

a When the temperature rise on the side of an enclosure that is intended for mounting against building materials exceeds 122 °F (50 °C) per UL 508 Table A.14, when operated under normal conditions, the construction shall be such that only the points of support are in contact with a plane mounting surface with the remainder of the equipment spaced at least 0.25 in. (6.4 mm) from the mounting surface such that the temperature rise of the supporting surface does not exceed 122 °F (50 °C).

b The temperature rise of an accessible surface of an enclosure is able to be exceeded when provided with the marking

indicated in Section 3.3.

Table A.12: Ampacity of insulated conductors for field wiring

Wire size		140 °F (60 °C)		167 °F (75 °C)	
AWG or kcmil	(mm <sup>2</sup> )	Copper	Aluminum <sup>d</sup>	Copper	Aluminum <sup>c,d</sup>
24	(0.20)	2	-	-	-
22	(0.32)	3	-	-	-
20	(0.52)	5	-	-	-
18	(0.82)	7	-	-	-
16	(1.3)	10	-	-	-
14	(2.1)	15	-	15	-
12	(3.3)	20	15	20	15
10	(5.3)	30	25	30	25
8	(8.4)	40	30	50/45 <sup>b</sup>	40/30 <sup>b</sup>
6	(13.3)	55	40	65	50
4	(21.2)	70	55	85	65
3	(26.7)	80	65	100	75
2	(33.6)	95/100 <sup>b</sup>	75	115	90
1	(42.4)	110 <sup>a</sup>	85 <sup>a</sup>	130	100
1/0	(53.5)	-	-	150	120
2/0	(67.4)	-	-	175	135
3/0	(85.0)	-	-	200	155
4/0	(107)	-	-	230	180
250	(127)	-	-	255	205
300	(152)	-	-	285	230
350	(177)	-	-	310	250
400	(203)	-	-	335	270
500	(253)	-	-	380	310
600	(304)	-	-	420	340
700	(355)	-	-	460	375
750	(380)	-	-	475	385
800	(405)	-	-	490	395
900	(456)	-	-	520	425
1 000	(506)	-	-	545	445
1 250	(633)	-	-	590	485
1 500	(760)	-	-	625	520
1 750	(887)	-	-	650	545
2 000	(1 010)	-	-	665	560

- 1 For a multiple conductor connector at a terminal, the value shall be multiplied by the number of conductors that the terminal will accommodate 1/0 AWG (53.5 mm<sup>2</sup>) or larger.
- 2 These values of ampacity apply only if not more than three conductors will be field-installed in the conduit. If four or more conductors, other than a neutral that carries the unbalanced current, will be installed in a conduit (as may occur because of the number of conduit hubs provided in an outdoor motor control centre because of the number of wires necessary in certain polyphase systems, or other reasons) the ampacity of each of those conductors is 80 percent of the value given in the table if 4 - 6 conductors are involved, 70 percent of that value if 7 - 24 conductors, 60 percent of that value if 25 - 42 conductors, and 50 percent of that value if 43 or more conductors.
  - a. If the motor control centre is marked to indicate that 167 °F (75 °C) wire shall be used at the terminal, the acceptable current is 130 A for a copper conductor and 100A for an aluminum conductor.
  - b. Differences are from CEC.
  - c. See product Standard for specific application.
  - d. The CEC Part 1 requires copper conductors only for fire pump service.

Table A.13: Width of 1/4 in. (6.4 mm) Uninsulated Copper Bus Bars

<b>Product rating, Amperes</b>	<b>Bus bars per terminal</b>	<b>Inches</b>	<b>(mm)</b>
450 - 600	1	2	(51)
601 - 1,000	1	3	(76)
1,001 - 1,200	1	4	(102)
1,201 - 1,600	2	3	(76)
1,601 - 2,000	2	4	(102)
2,001 - 2,500	2	5	(127)
	4	2-1/2	(64)
2,501 - 3,000	3	5	(127)
	4	4	(102)

Table A.14: Standard short circuit test values

<b>Rating,</b>		<b>Test current, amperes<sup>a</sup></b>	<b>Power factor</b>
<b>Horsepower</b>	<b>(kW)</b>		
0 - 1 <sup>b</sup>	(0 - 0.7)	1,000	0.70 - 0.80
1.5 - 50	(1.1 - 37.3)	5,000	0.70 - 0.80
51 - 200	(39 - 149)	10,000	0.70 - 0.80
201 - 400	(150 - 298)	18,000	0.25 - 0.30
401 - 600	(299 - 447)	30,000	0.20 or less
601 - 900	(448 - 671)	42,000	0.20 or less
901 - 1600	(672 - 1 193)	85,000	0.20 or less

a Symmetrical rms amperes.

b At 300V or less.

Table A.15. Recommended high fault short circuit ratings

7,500	25,000	65,000
10,000	30,000	85,000
14,000	35,000	100,000
18,000	42,000	125,000
20,000	50,000	150,000
22,000		200,000

Table A.16: Test Voltages for Verifying Clearances (See Section 5.15)

<b>Specified minimum through-air spacing in. (mm)</b>	<b>Test voltages for use at a 6561 ft. (2000 m) elevation, kV*</b>	
	<b>AC impulse, A.C. peak, or D.C.</b>	<b>AC rms</b>
0.0157 (0.4)	1.5	1.1
0.0315 (0.8)	1.9	1.3
0.0629 (1.6)	2.7	1.9
0.0945 (2.4)	3.5	2.5
0.1259 (3.2)	4.3	3.0
0.1889 (4.8)	5.6	4.0
0.2519 (6.4)	6.8	4.8
0.3740 (9.5)	8.8	6.3
0.4999 (12.7)	11.2	7.9



Table A.17: Test Voltages for Verifying Clearances at Altitudes Other Than 6561 ft. (2000 m) (See Section 5.15)

<b>Specified minimum through-air spacing</b>		<b>Test voltages, kV</b>							
		<b>AC impulse, A.C. peak, or D.C.</b>				<b>AC rms</b>			
		<b>Altitude</b>				<b>Altitude</b>			
		<b>Sea level</b>	<b>656 ft (200 m)</b>	<b>1640 ft. (500 m)</b>	<b>3280 ft. (1000 m)</b>	<b>Sea level</b>	<b>656 ft (200 m)</b>	<b>1640 ft. (500 m)</b>	<b>3280 ft. (1000 m)</b>
<b>in.</b>	<b>(mm)</b>								
0.0157	(0.4)	1.7	1.7	1.7	1.6	1.2	1.2	1.2	1.2
0.0315	(0.8)	2.2	2.1	2.1	2.0	1.5	1.5	1.5	1.4
0.0629	(1.6)	3.3	3.3	3.2	3.0	2.4	2.3	2.3	2.1
0.0945	(2.4)	4.4	4.3	4.1	3.9	3.1	3.0	2.9	2.8
0.1259	(3.2)	5.3	5.2	5.0	4.8	3.7	3.7	3.6	3.4
0.1889	(4.8)	6.9	6.8	6.6	6.2	4.9	4.8	4.7	4.4
0.2519	(6.4)	8.3	8.2	7.9	7.5	5.9	5.9	5.6	5.3
0.3740	(9.5)	10.9	10.7	10.3	9.8	7.7	7.7	7.3	7.0
0.4999	(12.7)	14.0	13.7	13.2	12.5	9.9	9.7	9.3	8.9

Appendix B: Figures

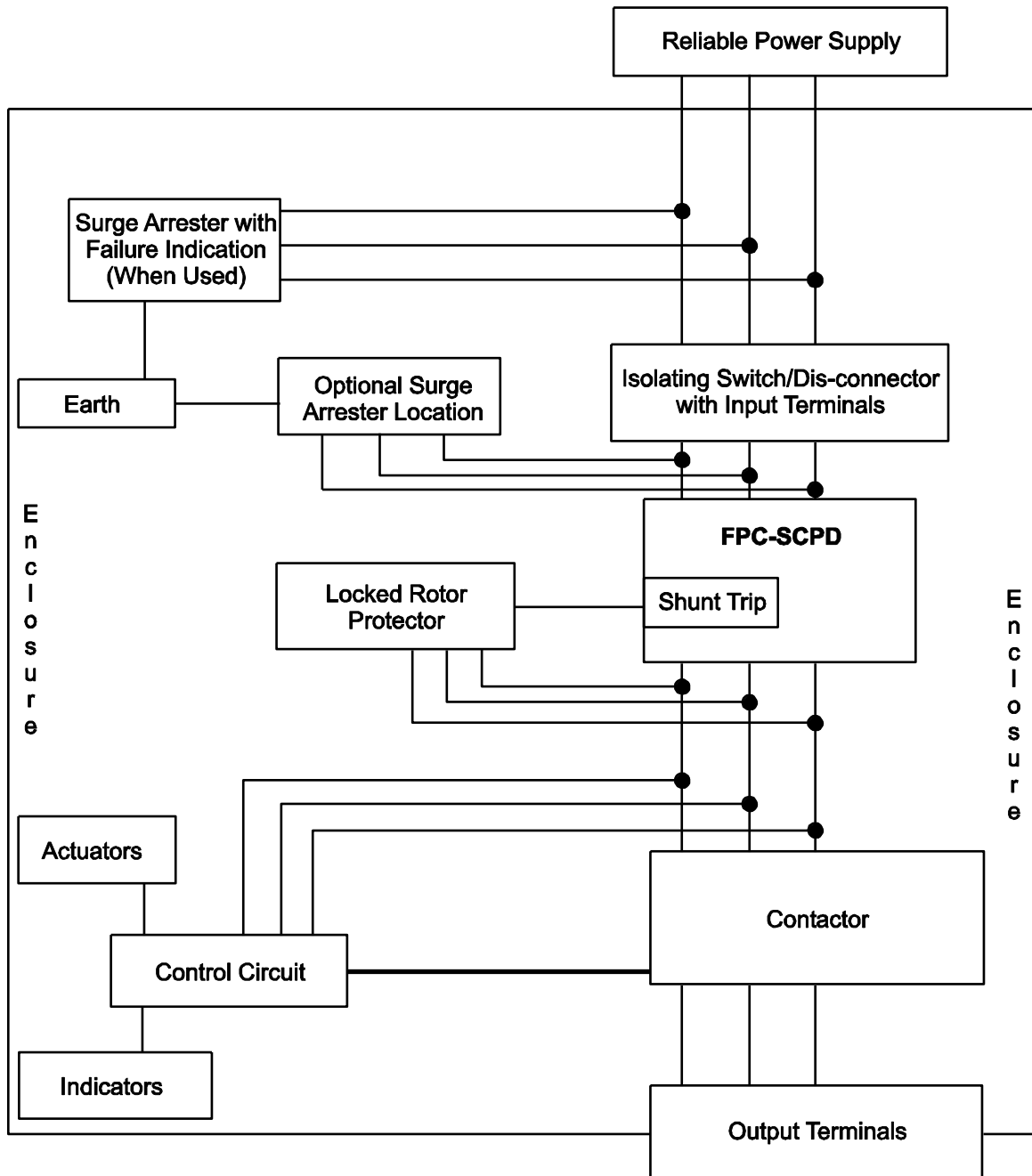
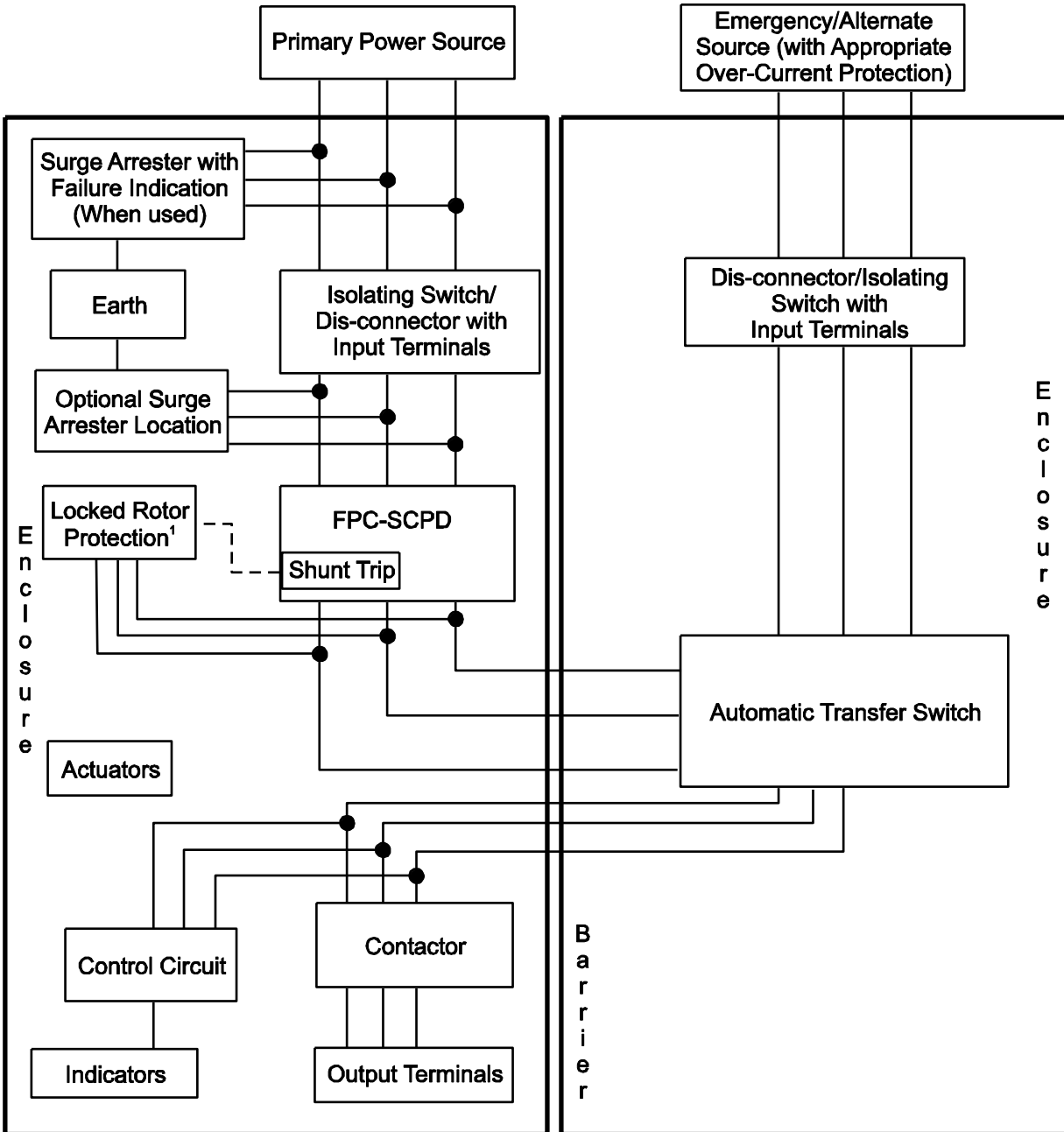
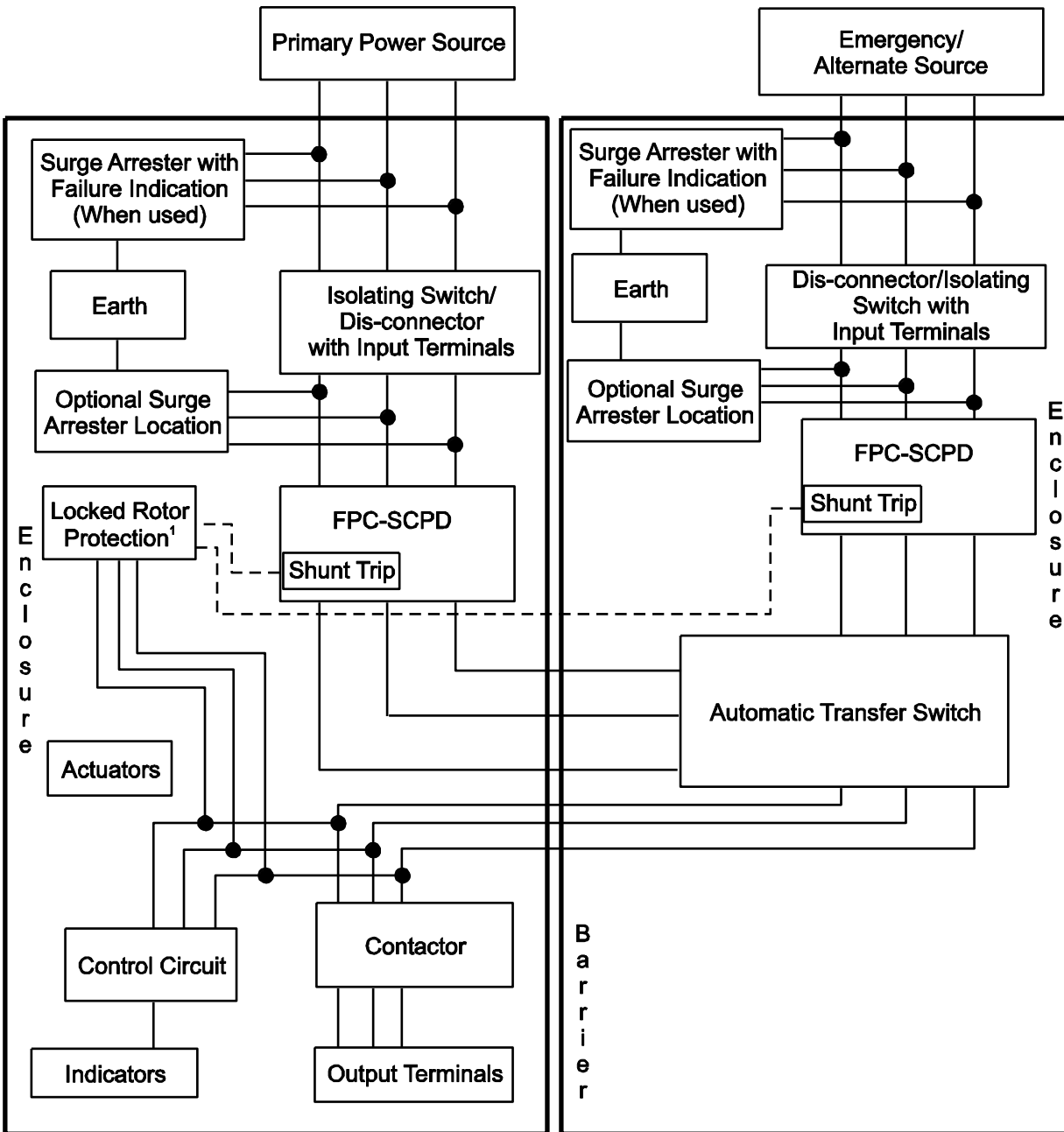

Figure B-1: General arrangement for the electric fire pump controller suitable for a single power source



<sup>1</sup> Location of Locked Rotor Protection Sensors (Current Transformers) is optional.

Figure B-2: Example of a general arrangement for the electric FPC with integrated automatic power transfer switch suitable for two power sources, the alternate source being on-site standby power.



<sup>1</sup> Location of Locked Rotor Protection Sensors (Current Transformers) is optional.

Figure B-3: Example of a general arrangement for the electric FPC with integrated automatic power transfer switch suitable for two power sources, both of which are utilities (with one locked rotor protector).

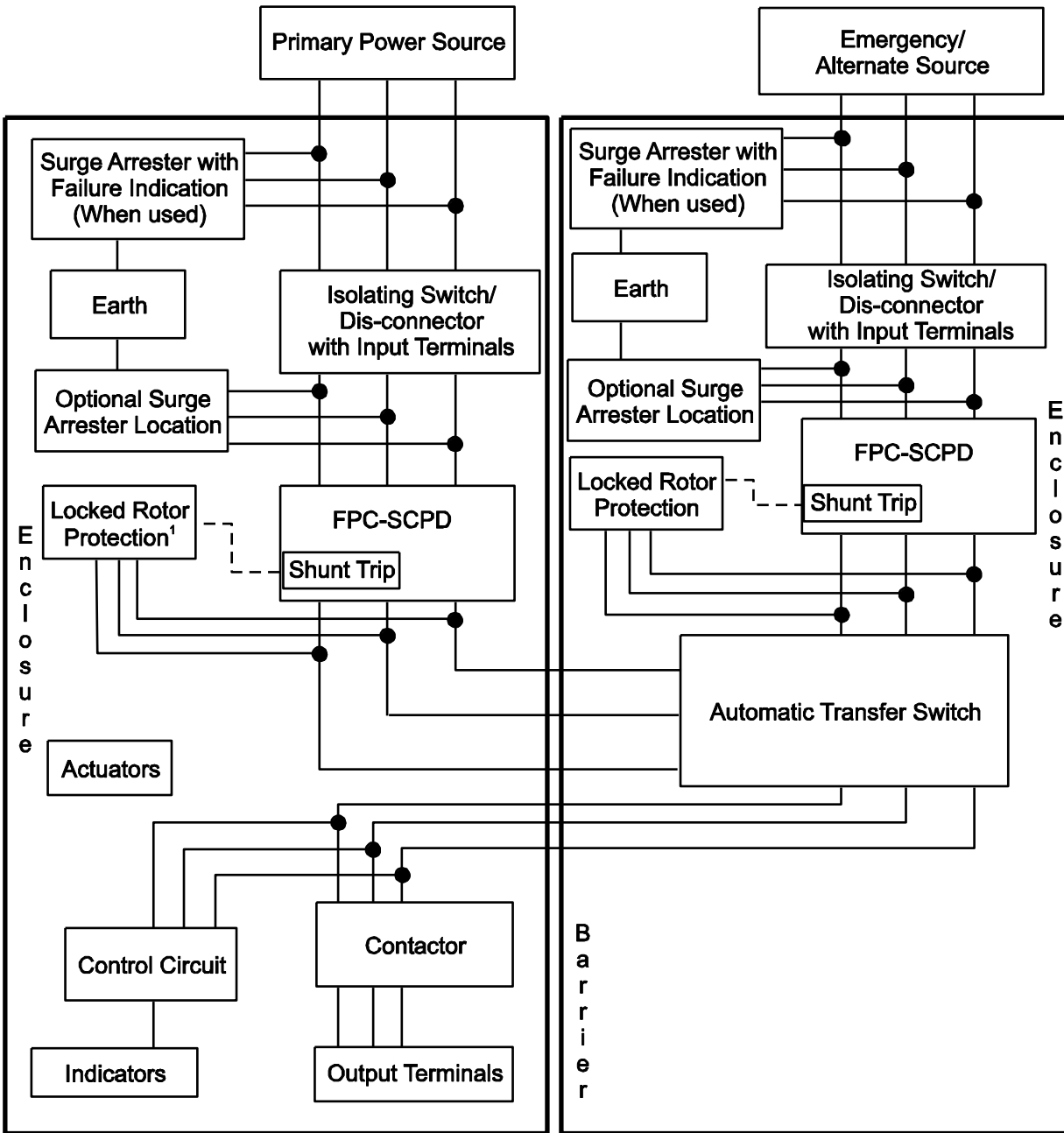

<sup>1</sup> Location of Locked Rotor Protection Sensors (Current Transformers) is optional.

Figure B-4: Example of a general arrangement for the electric FPC with integrated automatic power transfer switch suitable for two power sources, both of which are utilities (with two locked rotor protectors).

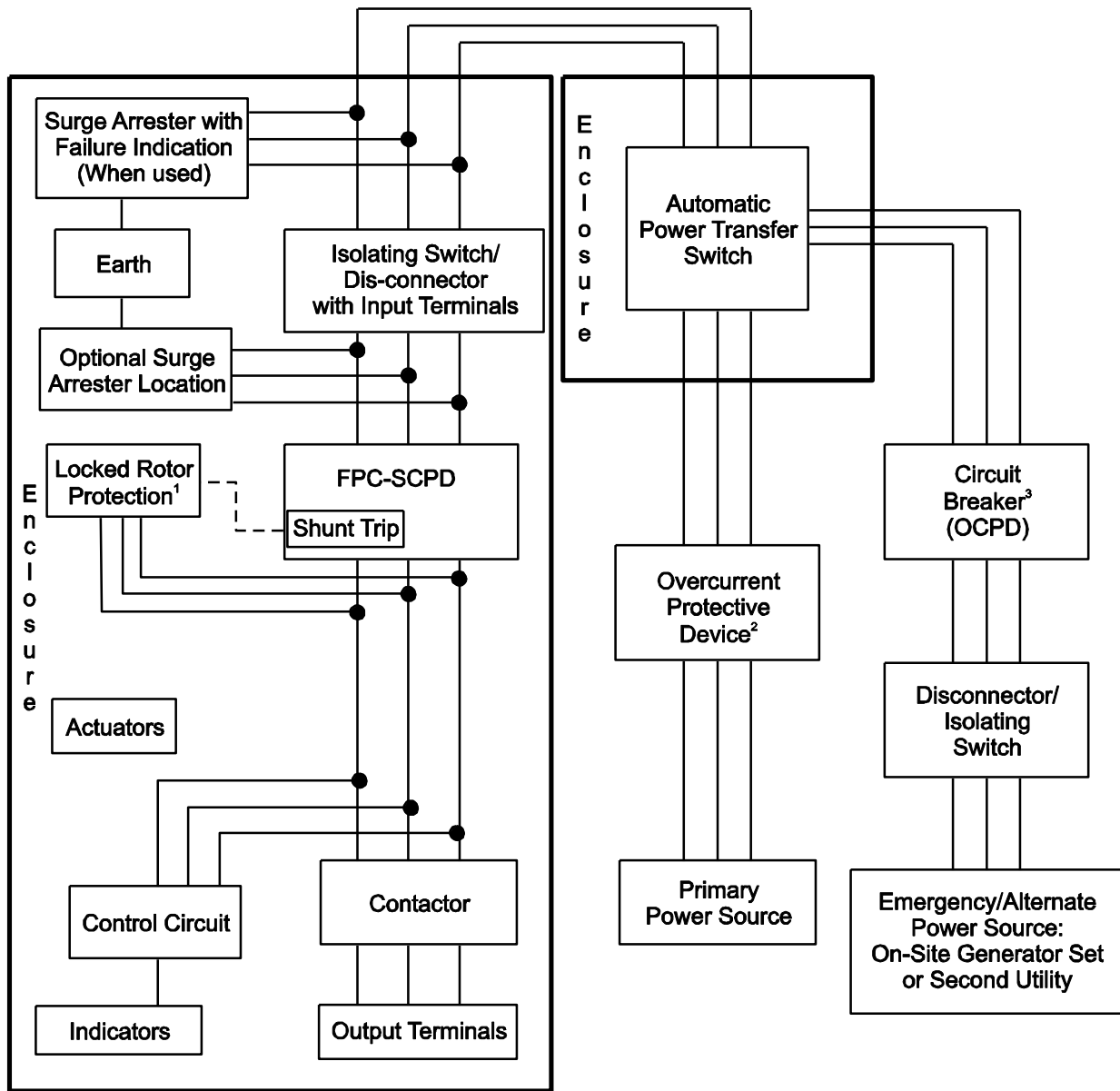

<sup>1</sup> Location of Locked Rotor Protection Sensors (Current Transformers) is optional.

<sup>2</sup> Circuit breakers or fusible switches can be used.

<sup>3</sup> Alternate source circuit breaker (OCPD) is optional when emergency/alternate source power is an on-site generator set

Figure B-5: Example of a general arrangement for the electric FPC with stand-alone automatic power transfer switch suitable for two power sources.

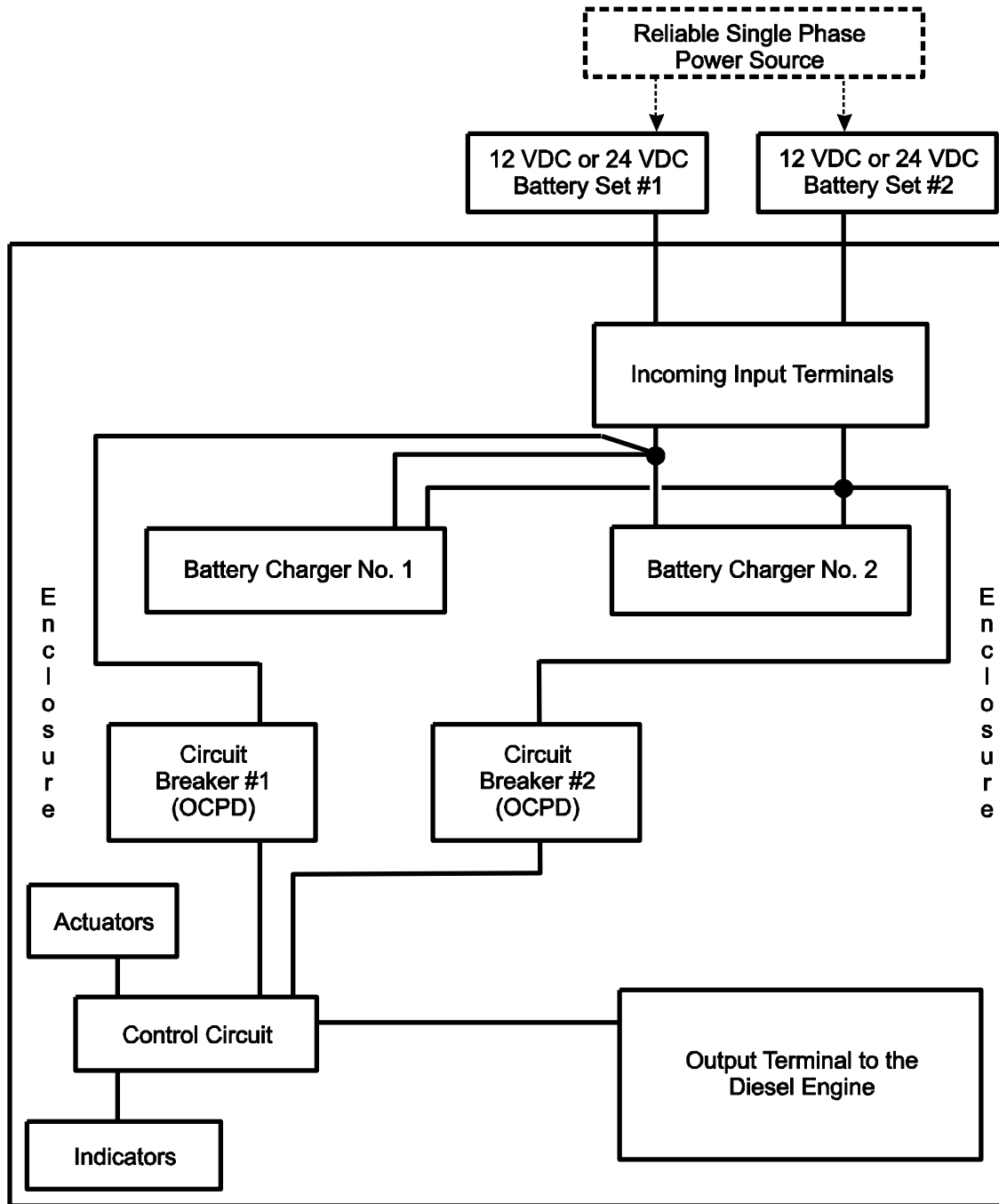

Figure B-6: Typical block diagram for the diesel engine fire pump controller suitable for a single phase power source

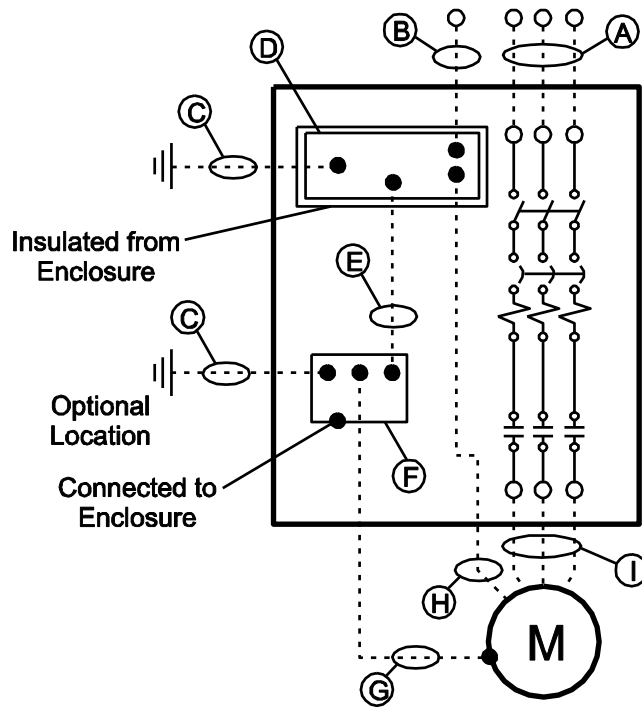

Figure B-7: Grounding/Bonding Terms

Typical three phase, four wire fire pump controller (three phase, four wire distribution)

Key to Figure B-7, Grounding/bonding terms

Letter Code	UL Terms	CEC Terms	ANCE Terms
A	Ungrounded Service Conductor	Ungrounded Service Conductor	Conductores De Fase De La Acometida
B	Grounded Service Conductor	Grounded Service Conductor	Conductor De Acometida Puesto A Tierra
C	Grounding Electrode Conductor	Grounding Conductor	Conductor De Electrodo De Puesta A Tierra
D	Insulated Neutral Bus	Neutral Bus	Barra Para Neutro
E	Bonding Jumper	Bonding Jumper	Puente De Union
F	Ground Bus	Bonding Bus/Bonding Connector	Barra Para Puesta A Tierra
G	Equipment Grounding Conductor	Bonding Conductor	Conductor De Puesta A Tierra Del Equipo
H	Grounded Circuit Conductor	Identified Circuit Conductor	Conductor Del Circuito Puesto A Tierra
I	Ungrounded Circuit Conductor	Ungrounded Circuit Conductor	Conductores De Fase Del Circuito



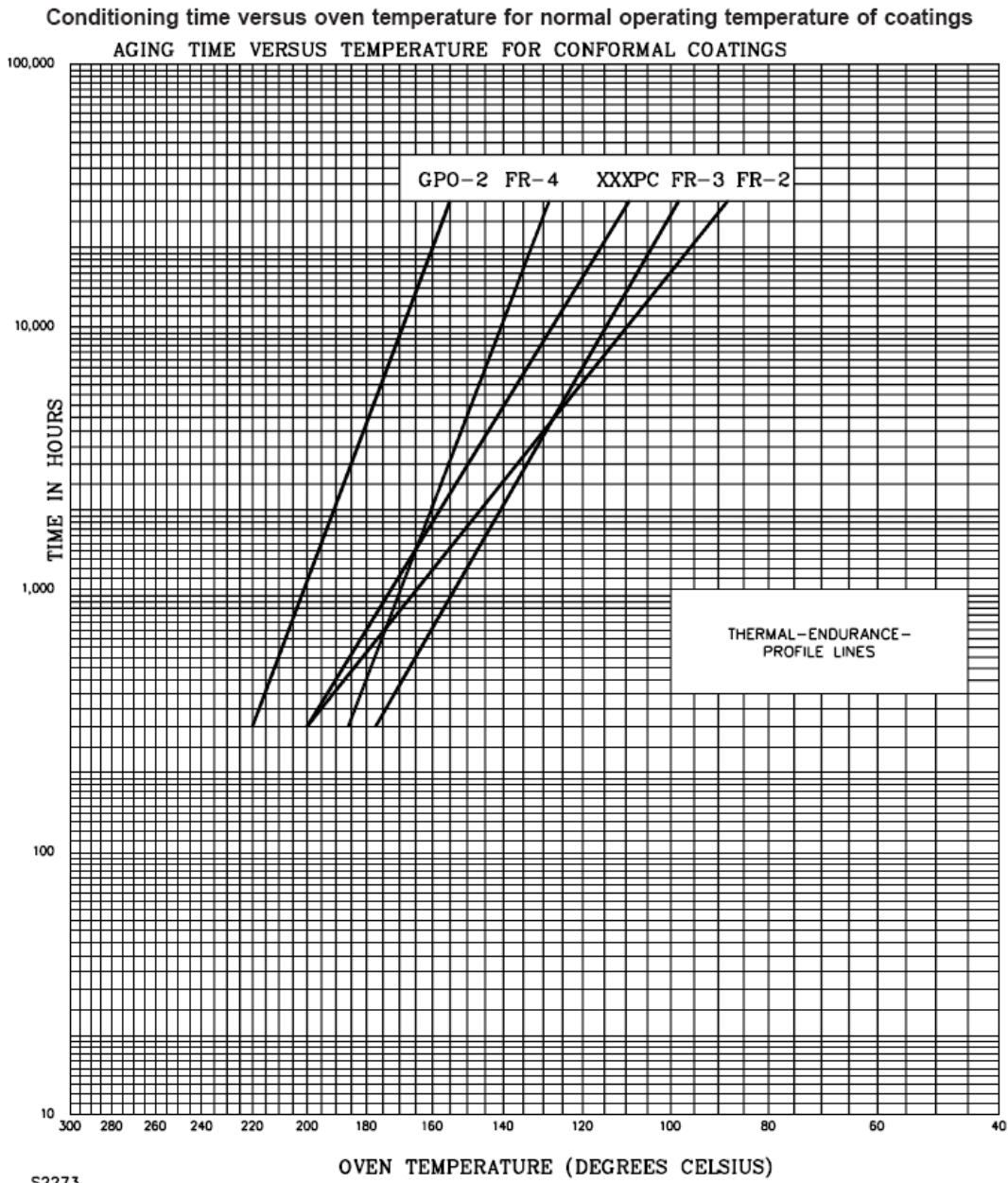

Figure B-8: Thermal Endurance Profile Curve

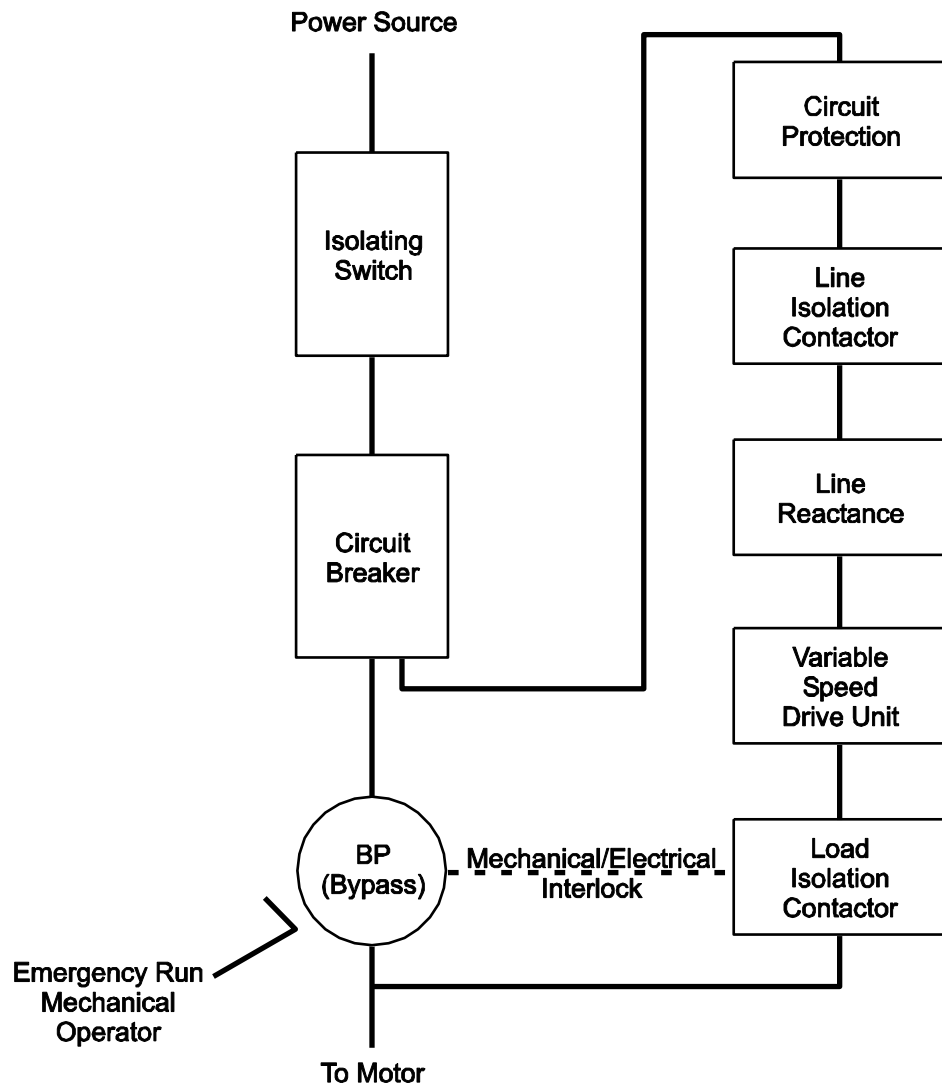

Figure B-9: Variable Speed Pressure Limiting Control

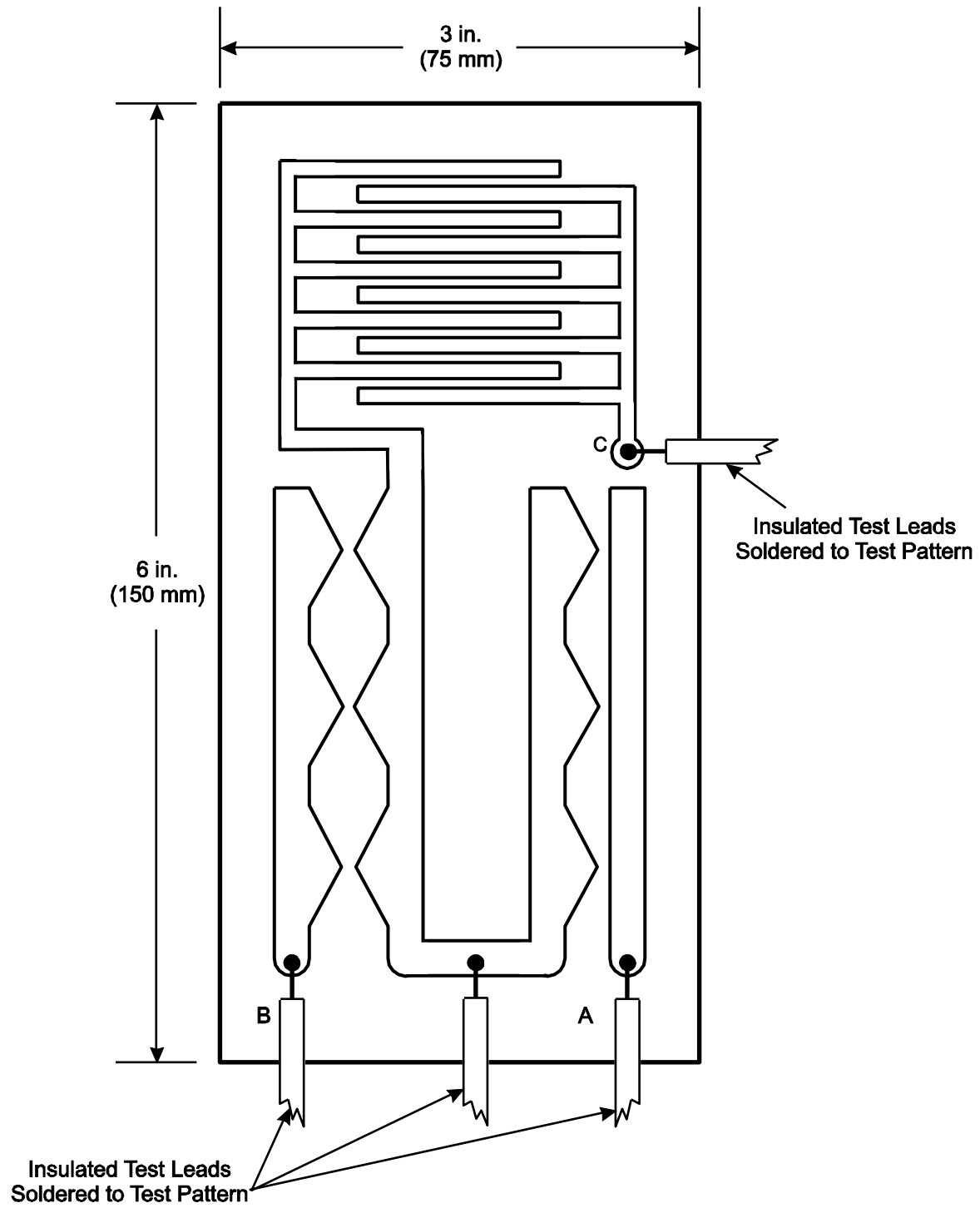
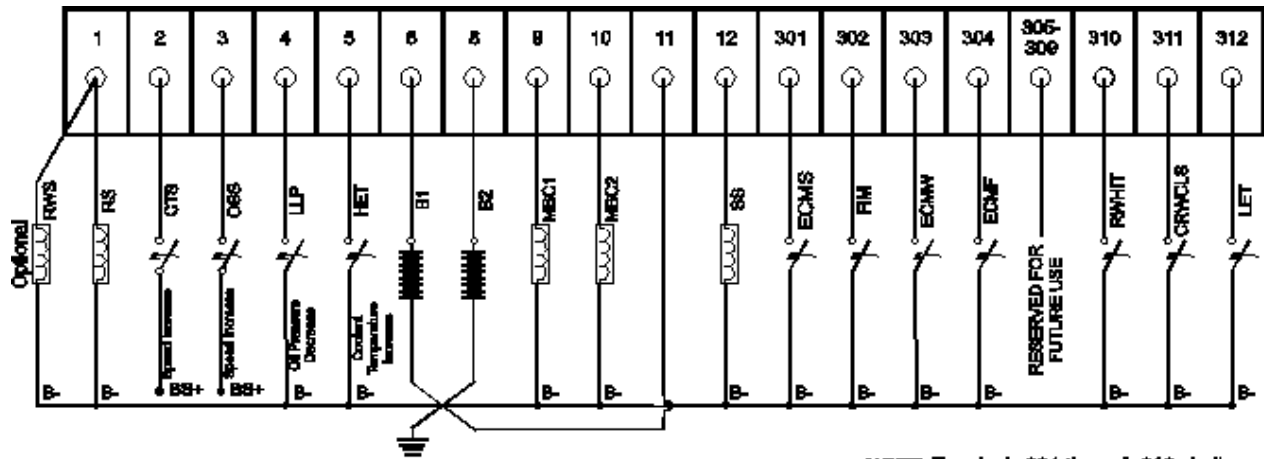

Figure B-10: Dielectric Test Pattern



**NOTE:** Terminals 301 through 312 shall be electrically isolated from the ECM (Electronic Control Module).

**LEGEND**

- |  |  |
|--|--|
| RWS - Raw Water Solenoid Valve (when Used)                   | SS - Shutdown Solenoid/Circuit                   |
| RS - Run Solenoid/Circuit                                    | ECMS - Electronic Control Module Switch          |
| CTS - Crank Termination Switch                               | FIM - Fuel Injection Malfunction                 |
| OSS - Overspeed Switch                                       | ECMW - Electronic Control Module Warning         |
| LLP - Low Lubricant Pressure Switch                          | ECMF - Electronic Control Module Failure         |
| HET - High Engine Temperature Signal                         | CRWCLS - Clogged raw water coolant loop strainer |
| B1 - Battery 1 Positive                                      | RWHIT - Raw water high inlet temperature         |
| B2 - Battery 2 Positive                                      | LET - Low Engine Temperature Switch              |
| MBC1 - Main Battery Contactor 1 coil or Battery Relay 1 coil | B- - Common Battery 1 and 2 Negative             |
| MBC2 - Main Battery Contactor 2 coil or Battery Relay 2 coil | BS+ - Battery System Positive                    |

Figure B-11: Diesel Engine Wiring Diagram

## Appendix C:

This page intentionally left blank

## Appendix D: Electromagnetic compatibility

(normative)

### D-1 General

This annex applies to controllers incorporating electronic circuits, which are not in compliance with 5.18.1.

### D-2 Definitions

For the purposes of this annex, the following definitions are applicable.

**Port**

Particular interface of the specified apparatus with the external electromagnetic environment (see Figure D.1)

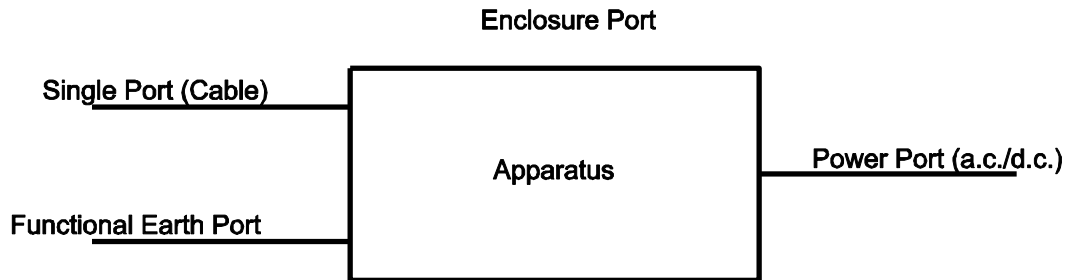

Figure D.1 Examples of Ports (IEC 1889/03)

**Enclosure Port**

Physical boundary of the apparatus through which electromagnetic fields may radiate or impinge.

**Cable Port**

Port at which a conductor or a cable is connected to the apparatus

**Note:** Examples are signal ports used for the transfer of data.

**Functional Earth Port**

Port other than signal, control or power port, intended for connection to earth for purposes other than electrical safety

**Signal port**

Port at which a conductor or cable carrying information for transferring data is connected to the apparatus

**Note:** Examples are data buses, communication networks, control networks.

**Power Port**

Port at which a conductor or cable carrying the primary electrical power needed for the operation (functioning) of an apparatus or associated apparatus is connected

Table D.1 – Emission Limits for Environment B per EN61000-6-3  
(These limits have been copied for information only without alteration from CISPR 11)

	<b>Frequency Range<sup>a</sup></b> <b>MHz</b>	<b>Limits</b>	<b>Reference Standard</b>
<b>Radiated Emissions</b>	<b>30 to 230</b> <b>230 to 1,000</b>	<b>30 dB(μV/m) quasi-peak at 10 m</b> <b>37 dB(μV/m) quasi-peak at 10 m</b> See Note	<b>(CISPR 61000-6-3</b> <b>or</b> <b>CISPR 11</b> <b>Class B, Group 1)</b>
<b>Conducted Emissions</b>	<b>0.15 to 0.5</b> <b>The limits decrease linearly with the log of the frequency</b>	<b>66 dB(μV) to 56 dB(μV) quasi-peak</b> <b>56 dB(μV) to 46 dB(μV) average</b>	<b>CISPR 11</b> <b>Class B, Group 1</b>
	<b>0.5 to 5</b>	<b>56 dB(μV) quasi-peak</b> <b>46 dB(μV) average</b>	
	<b>5 to 30</b>	<b>60 dB(μV) quasi-peak</b> <b>50 dB(μV) average</b>	

a The lower limit shall apply at the transition frequency

Note: May be measured at a distance of 9.84 ft. (3 m) with limits increased by 10 dB

Table D.2 - Immunity Tests for Industrial Environment A per EN61000-6-2

<b>Type of Test</b>	<b>Test Level Required</b>	<b>Performance Criterion</b>
<b>Electrostatic Discharges</b> <b>EN/IEC 61000-4-2</b>	<b>8 kV/ Air Discharge</b> <b>or 4 kV/ Contact Discharge</b>	<b>2</b>
<b>Radiated Radio-Frequency Electromagnetic Fields</b> <b>(80 MHz to 1 GHz and 1.4 GHz to 2 GHz)</b> <b>EN/IEC 61000-4-3</b>	<b>10 V/m</b>	<b>1</b>
<b>Electrical Fast Transients/Bursts</b> <b>EN/IEC 61000-4-4</b>	<b>2 kV on all Ports Connected to Supply Voltage</b> <b>1 kV on Signal Ports Including Auxiliary Circuits</b>	<b>2</b>
<b>Surges<sup>a</sup></b> <b>(1.2/50 μs - 8/20 μs)</b> <b>EN/IEC 61000-4-5</b>	<b>2 kV (Line to Earth)</b> <b>1 kV (Line to Line)</b>	<b>2</b>
<b>Conducted Disturbances Induced by Radio-Frequency Fields</b> <b>(150 kHz to 80kHz)</b> <b>EN/IEC 61000-4-6</b>	<b>10 V</b>	<b>1</b>
<b>Power-Frequency Magnetic Field<sup>b</sup></b> <b>EN/IEC 61000-4-8</b>	<b>30 A/m</b>	<b>1</b>
<b>Voltage dips and interruptions</b> <b>EN/IEC 61000-4-11 (2004)</b>	<b>30 percent Reduction for 0.5 Cycles</b>	<b>2</b>
	<b>60 percent Reduction for 5 and 50 Cycles</b>	<b>2</b>
<b>Harmonics in the Supply</b> <b>EN/IEC 61000-4-13</b>	<b>No Test Requirements</b>	

a For equipment and/or input/output ports with a rated voltage of 24 V D.C. or less, tests are not required.

b Applicable only to apparatus containing devices susceptible to magnetic fields.

Note: Performance criteria are independent of the environment.

Table D.3 – Acceptance criteria when electromagnetic disturbances are present  
(performance criteria during tests)

<i>Item</i>	<i>1</i>	<i>2</i>	<i>3</i>
<b>A. Overall Performance (Automatic and manual starting and running operations)</b>	<b>No noticeable changes of the operating characteristic</b>  <b>Operating as intended</b>	<b>Noticeable changes (visual or audible) of the operating characteristics</b>  <b>Self-recoverable</b>	<b>Changes in operating characteristics</b>  <b>Triggering of protective devices</b>  <b>Not self-recoverable</b>
<b>B. Operation of power and driving circuits</b>	<b>Starting and running capability shall be unimpaired</b>  <b>No maloperation</b>	<b>Temporary maloperation which cannot cause tripping, or erratic and audible changes in motor torque</b>	<b>Shut down</b>  <b>Triggering of protective devices</b>  <b>Not self-recoverable</b>
<b>C. Operation of displays and control panels</b>	<b>No changes to visible display information</b>  <b>Only slight light intensity fluctuation of LEDs, or slight movement of characters</b>	<b>Temporary visible changes or loss of information</b>  <b>Undesired LED illumination</b>	<b>Shutdown</b>  <b>Permanent loss of display or wrong information</b>  <b>Un-permitted operating mode</b>  <b>Not self-recoverable</b>
<b>D. Information processing and sensing functions</b>	<b>Undisturbed communication and data interchange to external devices</b>	<b>Temporarily disturbed communication, with possible error reports of the internal and external devices</b>	<b>Erroneous processing of information</b>  <b>Loss of data and/or information</b>  <b>Errors in communication</b>  <b>Not self-recoverable</b>
<b>E. Operation of auxiliary circuits to operation of the pump<sup>a</sup></b>	<b>Temporary minor degradation which is self-recoverable</b>	<b>Temporary degradation or loss of performance which is self-recoverable</b>	<b>Temporary degradation or loss of performance which requires operator intervention of system reset</b>

a. Operations not involved in starting and running the driver.



## Appendix E: NEMA Enclosure Types

The purpose of this document is to provide general information on the definitions of NEMA Enclosure Types to architects, engineers, installers, inspectors and other interested parties. [For more detailed and complete information, NEMA Standards Publication 250, “Enclosures for Electrical Equipment (1000 Volts Maximum)” shall be consulted. This Standards Publication as well as all other NEMA publications are available from IHS @ 800 854-7179 or <http://www.global.ihs.com>]

### Definitions [from NEMA 250]

In Non-Hazardous Locations, the specific enclosure Types, their applications, and the environmental conditions they are designed to protect against, **when completely and properly installed**, are as follows:

**Type 1** Enclosures constructed for indoor use to provide a degree of protection to personnel against access to hazardous parts and to provide a degree of protection of the equipment inside the enclosure against ingress of solid foreign objects (falling dirt).

**Type 2** Enclosures constructed for indoor use to provide a degree of protection to personnel against access to hazardous parts; to provide a degree of protection of the equipment inside the enclosure against ingress of solid foreign objects (falling dirt); and to provide a degree of protection with respect to harmful effects on the equipment due to the ingress of water (dripping and light splashing).

**Type 3** Enclosures constructed for either indoor or outdoor use to provide a degree of protection to personnel against access to hazardous parts; to provide a degree of protection of the equipment inside the enclosure against ingress of solid foreign objects (falling dirt and windblown dust); to provide a degree of protection with respect to harmful effects on the equipment due to the ingress of water (rain, sleet, snow); and that will be undamaged by the external formation of ice on the enclosure.

**Type 3R** Enclosures constructed for either indoor or outdoor use to provide a degree of protection to personnel against access to hazardous parts; to provide a degree of protection of the equipment inside the enclosure against ingress of solid foreign objects (falling dirt); to provide a degree of protection with respect to harmful effects on the equipment due to the ingress of water (rain, sleet, snow); and that will be undamaged by the external formation of ice on the enclosure.

**Type 3S** Enclosures constructed for either indoor or outdoor use to provide a degree of protection to personnel against access to hazardous parts; to provide a degree of protection of the equipment inside the enclosure against ingress of solid foreign objects (falling dirt and windblown dust); to provide a degree of protection with respect to harmful effects on the equipment due to the ingress of water (rain, sleet, snow); and for which the external mechanism(s) remain operable when ice laden.

**Type 3X** Enclosures constructed for either indoor or outdoor use to provide a degree of protection to personnel against access to hazardous parts; to provide a degree of protection of the equipment inside the enclosure against ingress of solid foreign objects (falling dirt and windblown dust); to provide a degree of protection with respect to harmful effects on the equipment due to the ingress of water (rain, sleet, snow); that provides an additional level of protection against corrosion and that will be undamaged by the external formation of ice on the enclosure.

**Type 3RX** Enclosures constructed for either indoor or outdoor use to provide a degree of protection to personnel against access to hazardous parts; to provide a degree of protection of the equipment inside the enclosure against ingress of solid foreign objects (falling dirt); to provide a degree of protection with respect to harmful effects on the equipment due to the ingress of water (rain, sleet, snow); that will be undamaged by the external formation of ice on the enclosure that provides an additional level of protection against corrosion; and that will be undamaged by the external formation of ice on the enclosure.

**Type 3SX** Enclosures constructed for either indoor or outdoor use to provide a degree of protection to personnel against access to hazardous parts; to provide a degree of protection of the equipment inside the enclosure against ingress of solid foreign objects (falling dirt and windblown dust); to provide a degree of protection with respect to harmful effects on the equipment due to the ingress of water (rain, sleet, snow); that provides an additional level of protection against corrosion; and for which the external mechanism(s) remain operable when ice laden.

**Type 4** Enclosures constructed for either indoor or outdoor use to provide a degree of protection to personnel against access to hazardous parts; to provide a degree of protection of the equipment inside the enclosure against ingress of solid foreign objects (falling dirt and windblown dust); to provide a degree of protection with respect to harmful effects on the equipment due to the ingress of water (rain, sleet, snow, splashing water, and hose directed water); and that will be undamaged by the external formation of ice on the enclosure.

**Type 4X** Enclosures constructed for either indoor or outdoor use to provide a degree of protection to personnel against access to hazardous parts; to provide a degree of protection of the equipment inside the enclosure against ingress of solid foreign objects (windblown dust); to provide a degree of protection with respect to harmful effects on the equipment due to the ingress of water (rain, sleet, snow, splashing water, and hose directed water); that provides an additional level of protection against corrosion; and that will be undamaged by the external formation of ice on the enclosure.

**Type 5** Enclosures constructed for indoor use to provide a degree of protection to personnel against access to hazardous parts; to provide a degree of protection of the equipment inside the enclosure against ingress of solid foreign objects (falling dirt and settling airborne dust, lint, fibers, and flyings); and to provide a degree of protection with respect to harmful effects on the equipment due to the ingress of water (dripping and light splashing).

**Type 6** Enclosures constructed for either indoor or outdoor use to provide a degree of protection to personnel against access to hazardous parts; to provide a degree of protection of the equipment inside the enclosure against ingress of solid foreign objects (falling dirt); to provide a degree of protection with respect to harmful effects on the equipment due to the ingress of water (hose directed water and the entry of water during occasional temporary submersion at a limited depth); and that will be undamaged by the external formation of ice on the enclosure.

**Type 6P** Enclosures constructed for either indoor or outdoor use to provide a degree of protection to personnel against access to hazardous parts; to provide a degree of protection of the equipment inside the enclosure against ingress of solid foreign objects (falling dirt); to provide a degree of protection with respect to harmful effects on the equipment due to the ingress of water (hose directed water and the entry of water during prolonged submersion at a limited depth); that provides an additional level of protection against corrosion and that will be undamaged by the external formation of ice on the enclosure.

**Type 12** Enclosures constructed (without knockouts) for indoor use to provide a degree of protection to personnel against access to hazardous parts; to provide a degree of protection of the equipment inside the enclosure against ingress of solid foreign objects (falling dirt and circulating dust, lint, fibers, and flyings); and to provide a degree of protection with respect to harmful effects on the equipment due to the ingress of water (dripping and light splashing).

**Type 12K** Enclosures constructed (with knockouts) for indoor use to provide a degree of protection to personnel against access to hazardous parts; to provide a degree of protection of the equipment inside the enclosure against ingress of solid foreign objects (falling dirt and circulating dust, lint, fibers, and flyings); and to provide a degree of protection with respect to harmful effects on the equipment due to the ingress of water (dripping and light splashing).

**Type 13** Enclosures constructed for indoor use to provide a degree of protection to personnel against access to hazardous parts; to provide a degree of protection of the equipment inside the enclosure against ingress of solid foreign objects (falling dirt and circulating dust, lint, fibers, and flyings); to provide a degree of protection with respect to harmful effects on the equipment due to the ingress of water (dripping and light splashing); and to provide a degree of protection against the spraying, splashing, and seepage of oil and non-corrosive coolants.

Table E.1: Comparison of Specific Applications of Enclosures for Indoor Nonhazardous Locations  
[From NEMA 250]

Provides a Degree of Protection Against the Following Conditions	Type of Enclosure									
	1*	2*	4	4X	5	6	6P	12	12K	13
Access to hazardous parts	X	X	X	X	X	X	X	X	X	X
Ingress of solid foreign objects (falling dirt)	X	X	X	X	X	X	X	X	X	X
Ingress of water (Dripping and light splashing)	...	X	X	X	X	X	X	X	X	X
Ingress of solid foreign objects (Circulating dust, lint, fibers, and flyings **)	...	...	X	X	...	X	X	X	X	X
Ingress of solid foreign objects (Settling airborne dust, lint, fibers, and flyings **)	...	...	X	X	X	X	X	X	X	X
Ingress of water (Hosedown and splashing water)	...	...	X	X	...	X	X	...	...	...
Oil and coolant seepage	...	...	...	...	...	...	...	X	X	X
Oil or coolant spraying and splashing	...	...	...	...	...	...	...	...	...	X
Corrosive agents	...	...	...	X	...	...	X	...	...	...
Ingress of water (Occasional temporary submersion)	...	...	...	...	...	X	X	...	...	...
Ingress of water (Occasional prolonged submersion)	...	...	...	...	...	...	X	...	...	...

\* These enclosures may be ventilated.

\*\* These fibers and flyings are nonhazardous materials and are not considered Class III type ignitable fibers or combustible flyings. For Class III type ignitable fibers or combustible flyings see the National Electrical Code, Article 500.

Table E.2: Comparison of Specific Applications of Enclosures for Outdoor Nonhazardous Locations  
[From NEMA 250]

Provides a Degree of Protection Against the Following Conditions	Type of Enclosure									
	3	3X	3R*	3RX*	3S	3SX	4	4X	6	6P
Access to hazardous parts	X	X	X	X	X	X	X	X	X	X
Ingress of water (Rain, snow, and sleet **)	X	X	X	X	X	X	X	X	X	X
Sleet ***	...	...	...	...	X	X	...	...	...	...
Ingress of solid foreign objects (Windblown dust, lint, fibers, and flyings)	X	X	...	...	X	X	X	X	X	X
Ingress of water (Hosedown)	...	...	...	...	...	...	X	X	X	X
Corrosive agents	...	X	...	X	...	X	...	X	...	X
Ingress of water (Occasional temporary submersion)	...	...	...	...	...	...	...	...	X	X
Ingress of water (Occasional prolonged submersion)	...	...	...	...	...	...	...	...	...	X

\* These enclosures may be ventilated.

\*\* External operating mechanisms are not required to be operable when the enclosure is ice covered.

\*\*\* External operating mechanisms are operable when the enclosure is ice covered.

In Hazardous Locations, when completely and properly installed and maintained, Type 7 and 10 enclosures are designed to contain an internal explosion without causing an external hazard. Type 8 enclosures are designed to prevent combustion through the use of oil-immersed equipment. Type 9 enclosures are designed to prevent the ignition of combustible dust.

**Type 7** Enclosures constructed for indoor use in hazardous (classified) locations classified as Class I, Division 1, Groups A, B, C, or D as defined in NFPA 70.

**Type 8** Enclosures constructed for either indoor or outdoor use in hazardous (classified) locations classified as Class I, Division 1, Groups A, B, C, and D as defined in NFPA 70.

**Type 9** Enclosures constructed for indoor use in hazardous (classified) locations classified as Class II, Division 1, Groups E, F, or G as defined in NFPA 70.

**Type 10** Enclosures constructed to meet the requirements of the Mine Safety and Health Administration, 30 CFR, Part 18.

Table E.3 *Comparison of Specific Applications of Enclosures for Indoor Hazardous Locations*  
 (If the installation is outdoors and/or additional protection is required by  
 Table 1 and Table 2, a combination-type enclosure is required.)  
 [From NEMA 250]

<i>Provides a Degree of Protection Against Atmospheres Typically Containing (See NFPA 497M for Complete Listing)</i>	<i>Class</i>	<i>Enclosure Types 7 and 8, Class I Groups**</i>				<i>Enclosure Type 9, Class II Groups</i>			
		<i>A</i>	<i>B</i>	<i>C</i>	<i>D</i>	<i>E</i>	<i>F</i>	<i>G</i>	<i>10</i>
Acetylene	I	X	...	...	...	...	...	...	...
Hydrogen, manufactured gas	I	...	X	...	...	...	...	...	...
Diethyl ether, ethylene, cyclopropane	I	...	...	X	...	...	...	...	...
Gasoline, hexane, butane, naphtha, propane, acetone, toluene, isoprene	I	...	...	...	X	...	...	...	...
Metal dust	II	...	...	...	...	X	...	...	...
Carbon black, coal dust, coke dust	II	...	...	...	...	...	X	...	...
Flour, starch, grain dust	II	...	...	...	...	...	...	X	...
Fibers, flyings*	III	...	...	...	...	...	...	X	...
Methane with or without coal dust	MSHA	...	...	...	...	...	...	...	X

\* For Class III type ignitable fibers or combustible flyings see the National Electrical Code, Article 500.

\*\* Due to the characteristics of the gas, vapor, or dust, a product suitable for one Class or Group may not be suitable for another Class or Group unless marked on the product.

**Comparison Between NEMA Enclosure Type Numbers and IEC Enclosure Classification Designations**

IEC Publication 60529 Classification of Degrees of Protection Provided by Enclosures provides a system for specifying the enclosures of electrical equipment on the basis of the degree of protection provided by the enclosure. IEC 60529 does not specify degrees of protection against mechanical damage of equipment, risk of explosions, or conditions such as moisture (produced for example by condensation), corrosive vapors, fungus, or vermin. The NEMA Standard for Enclosures for Electrical Equipment does test for environmental conditions such as corrosion, rust, icing, oil, and coolants. For this reason, and because the test and evaluations for other characteristics are not identical, the IEC Enclosure Classification Designations cannot be exactly equated with the enclosure Type numbers in this Standard.

The IEC designation consists of the letters IP followed by two numerals. The first characteristic numeral indicates the degree of protection provided by the enclosure with respect to persons and solid foreign objects entering the enclosure. The second characteristic numeral indicates the degree of protection provided by the enclosure with respect to the harmful ingress of water.

Table E.4 provides an equivalent conversion from the enclosure Type numbers in this Standard to the IEC Enclosure Classification Designations. The enclosure type numbers meet or exceed the test requirements for the associated IEC Classification; for this reason Table E.4 cannot be used to convert from IEC Classifications to enclosure Type numbers.

Table E.4: Conversion of NEMA Enclosure Type Ratings to IEC 60529 Enclosure Classification Designations (IP)  
(Cannot be used to Convert IEC Classification Designations to NEMA Type Ratings)

IP First Character	NEMA Enclosure Type																IP Second Character	
	1	2	3, 3X, 3S, 3SX	3R, 3RX	4, 4X	5	6	6P	12, 12K, 13									
IPO	■	■	■	■	■	■	■	■	■	■	■	■	■	■	■	■	■	IP 0
IP1	■		■	■	■	■	■	■	■	■	■	■	■	■	■	■	■	IP 1
IP2	■		■	■	■	■	■	■	■	■	■	■	■	■	■	■	■	IP 2
IP3			■	■	■	■	■	■	■	■	■	■	■	■	■	■	■	IP 3
IP4				■	■	■	■	■	■	■	■	■	■	■	■	■	■	IP 4
IP5					■	■	■	■	■	■	■	■	■	■	■	■	■	IP 5
IP6								■	■	■	■	■	■	■	■	■	■	IP 6
													■	■	■	■	■	IP 7
																	■	IP 8
	A	B	A	B	A	B	A	B	A	B	A	B	A	B	A	B	A	B

- A A shaded block in the "A" column indicates that the NEMA Enclosure Type exceeds the requirements for the respective IEC 60529 IP First Character Designation. The IP First Character Designation is the protection against access to hazardous parts and solid foreign objects.
- B A shaded block in the "B" column indicates that the NEMA Enclosure Type exceeds the requirements for the respective IEC 60529 IP Second Character Designation. The IP Second Character Designation is the protection against the ingress of water.

**EXAMPLE OF TABLE USE**

An IEC IP 45 Enclosure Rating is specified. What NEMA Type Enclosures meet and exceed the IP 45 rating?

Referencing the first character, 4, in the IP rating and the row designated "IP4\_" in the leftmost column in the table; the blocks in Column "A" for NEMA Types 3, 3X, 3S, 3SX, 4, 4X, 5, 6, 6P, 12, 12K, and 13 are shaded. These NEMA ratings meet and exceed the IEC protection requirements against access to hazardous parts and solid foreign objects.

Referencing the second character, 5, in the IP rating and the row designated "IP\_5" in the rightmost column in the table; the blocks in Column "B" for NEMA Types 3, 3X, 3S, 3SX, 4, 4X, 6, and 6P are shaded. These NEMA ratings meet and exceed the IEC requirements for protection against the ingress of water. The absence of shading in Column "B" beneath the "NEMA Enclosure Type 5" indicates that Type 5 does not meet the IP 45 protection requirements against the ingress of water. Likewise the absence of shading in Column "B" for NEMA Type 12, 12K and 13 enclosures indicates that these enclosures do not meet the IP 45 requirements for protection against the ingress of water. Only Types 3, 3X, 3S, 3SX, 4, 4X, 6, and 6P have both Column "A" in the "IP4\_" row and Column "B" in the "IP\_5" row shaded and could be used in an IP45 application.

The NEMA Enclosure Type 3 not only meets the IP 45 Enclosure Rating, but also exceeds the IEC requirements because the NEMA Type **requires** an outdoor corrosion test; a gasket aging test; a dust test; an external icing test; and **no** water penetration in the rain test. Slight differences exist between the IEC and NEMA test methods, but the IEC rating **permits** the penetration of water if "it does not deposit on insulation parts, or reach live parts." The IEC rating does **not** require a corrosion test; gasket aging test; dust test or external icing test. Because the NEMA ratings include additional test requirements, this table **cannot** be used to select IP Designations for NEMA rated enclosure specifications.

IEC 60529 specifies that an enclosure shall only be designated with a stated degree of protection indicated by the first characteristic numeral if it also complies with all lower degrees of protection. Furthermore IEC 60529 states that an enclosure shall only be designated with a degree of protection indicated by the second characteristic numeral if it also complies with all lower degrees of protection up to and including the second

characteristic numeral 6. An enclosure designated with a second characteristic numeral 7 or 8 only is considered unsuitable for exposure to water jets (designated by second characteristic numeral 5 or 6) and need not comply with requirements for numeral 5 or 6 unless it is dual coded. Since the IEC protection requirements become more stringent with increasing IP character value up through 6, once a NEMA Type rating meets the requirements for an IP designation up through 6, it will also meet the requirements for all lower IP designations. This is apparent from the shaded areas shown in the table.

This section was reprinted with permission from the National Electrical Manufacturers Association, 1300 N. 17<sup>th</sup> Street, Suite 1752, Rosslyn, VA 22209.

## Appendix F:

This page intentionally left blank.



## Appendix G: Tolerance

Unless otherwise stated, the following tolerances shall apply:

Angle:	$\pm 2^\circ$
Current	$\pm 2$ percent of value
Frequency (Hz):	$\pm 5$ percent of value
Length:	$\pm 2$ percent of value
Volume:	$\pm 5$ percent of value
Volume Per Unit Area:	$\pm 5$ percent of value
Power	$\pm 2$ percent of value
Pressure:	$\pm 5$ percent of value
Temperature:	$\pm 4$ °F (2 °C)
Time:	+ 0.5/-0 seconds +0./-0 minutes
Volts D.C.	$\pm 1$ percent of value
Volts A.C.	$\pm 2$ percent of value

Unless stated otherwise, all tests shall be carried out at a room (ambient) temperature of 68 °F  $\pm$  9 °F (20 °C  $\pm$  5 °C).

## Appendix H: Sample Listing

### Fire Pump Controllers —Electric Motor

Controllers for electric motor-driven fire pumps as listed are for alternating current squirrel-cage motors unless indicated as for slip ring motors. They are available for manual operation alone or for combined manual and automatic operation. Controllers for squirrel-cage motors are Certified for three phase power. They are of two primary types: across-the-line and reduced voltage. All model code combinations may not apply.

<b>Manufacturer’s Name, Manufacturer’s Listing Address</b>
<b><u>Fire Pump Controller (Rated 600 Volts or Less)</u></b>
<b>Model Xabcde</b>
<b>a = Starting Methods:</b>
<b>b = Horsepower Ratings:</b>
<b>c = Voltage Ratings:</b>
<b>d = Motor Frequency Ratings:</b>
<b>e = Options:</b>
<b><u>Fire Pump Controller with combined Automatic Power Transfer Switch (Rated 600 Volts or Less)</u></b>
<b>Model Xabcde</b>
<b>a = Starting Methods:</b>
<b>b = Horsepower Ratings:</b>
<b>c = Voltage Ratings:</b>
<b>d = Transfer Switch Ratings:</b>
<b>e = Options:</b>
<b><u>Variable Speed Fire Pump Controller (Rated 600 Volts or Less)</u></b>
<b>Model Xabcde</b>
<b>a = Starting Methods:</b>
<b>b = Horsepower Ratings:</b>
<b>c = Voltage Ratings:</b>
<b>d = Transfer Switch Ratings:</b>
<b>e = Options:</b>
<b><u>Medium / High Voltage Fire Pump Controller (Rated in Excess of 600 Volts)</u></b>
<b>Model Xabcde</b>
<b>a = Starting Methods:</b>
<b>b = Horsepower Ratings:</b>
<b>c = Voltage Ratings:</b>
<b>d = Motor Frequency Ratings:</b>
<b>e = Options:</b>
<b><u>Controller for Additive/Foam Pump Motor (Rated 600 Volts or Less)</u></b>
<b>Model Xabcde</b>
<b>a = Starting Methods:</b>
<b>b = Horsepower Ratings:</b>

<b>c = Voltage Ratings:</b>
<b>d = Motor Frequency Ratings:</b>
<b>e = Options:</b>
<b>Stand Alone Automatic Power Transfer Switch for Fire Pump Controller (Rated 600 Volts or Less)</b>
<b>Model Xabcde</b>
<b>a = Horsepower Ratings:</b>
<b>b = Voltage Ratings:</b>
<b>c = Motor Frequency Ratings:</b>
<b>d = Options:</b>
<b>Pressure Sensing Devices</b>
<b>Listed Controllers are certified with the following specific pressure sensing devices, or those pressure sensing devices listed in the ‘specification tested products’ section of the Guide.</b>
<b>1. Model A Pressure Transducer manufactured by company B.</b>
<b>2. Model C Pressure Switch manufactured by company D.</b>

**Fire Pump Controllers — Diesel Engine**

Controllers that provide an automatic means for starting internal combustion engine-driven fire pump units. These controllers are designed for dual battery operation.

<b>Manufacturer’s Name, Manufacturer’s Listing Address</b>
<b>Diesel Engine Fire Pump Controller</b>
<b>Model Yabcde</b>
<b>a = Battery Voltage: (VDC)</b>
<b>b = Charger Supply Voltage: (V A.C.)</b>
<b>c = Ground Polarity:</b>
<b>d = Frequency Ratings:</b>
<b>e = Options:</b>

**Fire Pump Controllers — Auxiliary Equipment/Components**

<b>Manufacturer’s Name, Manufacturer’s Listing Address</b>
<b>Product Description.</b>
<b>Model Number</b>
<b>a = Ratings (as applicable):</b>