



Examination Standard for Automatic Sprinklers for Fire Protection

Class Number 2000

November 2024

Foreword

This standard is intended to verify that the products and services described will meet stated conditions of performance, safety and quality useful to the ends of property conservation. The purpose of this standard is to present the criteria for examination of various types of products and services.

Examination in accordance with this standard shall demonstrate compliance and verify that quality control in manufacturing shall ensure a consistent and reliable product.

Table of Contents

1 INTRODUCTION	1
1.1 Purpose	1
1.2 Scope	1
1.3 Basis for Requirements.....	2
1.4 Basis for Certification.....	2
1.5 Basis for Continued Certification.....	2
1.6 Effective Date.....	2
1.7 System of Units	2
1.8 Normative References	3
1.9 Definitions	3
2 GENERAL INFORMATION.....	9
2.1 Product Information.....	9
2.2 Certification Application Requirements.....	9
2.3 Requirements for Samples for Examination.....	9
3 GENERAL REQUIREMENTS.....	10
3.1 Review of Documentation.....	10
3.2 Physical or Structural Features.....	10
3.3 Markings.....	11
3.4 Manufacturer's Installation and Operation Instructions	14
3.5 Calibration	14
4 PERFORMANCE REQUIREMENTS.....	15
4.1 Examination.....	15
4.2 Assembly Load/Frame Strength	15
4.3 Strength of Heat Responsive Element.....	16
4.4 Leakage.....	17
4.5 Hydrostatic Strength.....	17
4.6 30-Day Leakage.....	18
4.7 Water Hammer	18
4.8 Operating Temperature (Liquid Bath).....	18
4.9 Air Bath	19
4.10 Hang-Up of Operating Parts	20
4.11 Strength of Deflector (Flow Endurance)	21
4.12 Vacuum	21
4.13 High Ambient Temperature Exposure (90 Day Test).....	21
4.14 Thermal Shock (Glass Bulb Sprinklers Only).....	23
4.15 Discharge Coefficient (K-Factor).....	23
4.16 Moist Air	24
4.17 Corrosion - Salt Spray	24
4.18 Corrosion - Stress Cracking.....	25
4.19 Corrosion - Carbon Dioxide-Sulfur Dioxide	26
4.20 Corrosion - Hydrogen Sulfide	27
4.21 Vibration.....	28
4.22 Rough Use and Abuse	29
4.23 High Temperature Exposure.....	30
4.24 Freezing	30
4.25 Minimum Operating Pressure.....	30
4.26 Process Residue	31

4.27 Conductivity (C-Factor)	31
4.28 Sensitivity - Response Time Index (RTI).....	33
4.29 Sensitivity (Recessed, Flush, and Concealed Types)	34
4.30 Sensitivity (Air Oven)	36
4.31 Distribution - Standard Coverage Sprinklers.....	37
4.32 Distribution – Extended Coverage Hazard Category 1 (HC-1) Sprinklers	39
4.33 Distribution - K14.0 (K200) Non-Storage Extended Coverage Horizontal Sidewall Sprinklers.....	41
4.34 Impingement (Angle of Protection).....	41
4.35 Actual Delivered Density (ADD) - Extended Coverage Sprinklers for Protection of Hazard Categories 1 – 3 (HC-1 through HC-3).....	42
4.36 Actual Delivered Density (ADD) - K19.6 (K280) Pendent Storage Sprinklers	44
4.37 Actual Delivered Density (ADD) - K25.2 (K360) Storage Sprinklers.....	46
4.38 Fire - Standard Crib	47
4.39 Fire Tests - K11.2 (K160) Upright and Pendent Storage Sprinklers	48
4.40 Fire Tests - K14.0 (K200) Upright and Pendent Storage Sprinklers	49
4.41 Fire Tests - K14.0 (K200) Extended Coverage Sprinklers for Protection of Hazard Categories 1 – 3 (HC-1 through HC-3)	50
4.42 Fire Tests - K14.0 (K200) Non-Storage Extended Coverage Horizontal Sidewall Sprinklers.....	51
4.43 Fire Tests - K16.8 (K240) Upright Storage Sprinklers.....	55
4.44 Fire Tests - K19.6 (K280) Pendent Storage Sprinklers	56
4.45 Fire Tests - (K25.2 (K360) Upright and Pendent Storage Sprinklers)	58
4.46 Fire Tests - K25.2EC (K360EC) Upright and Pendent Storage Sprinklers.....	59
5 MANUFACTURER’S REQUIREMENTS	61
5.1 Demonstrated Quality Control Program.....	61
5.2 Surveillance Audit.....	62
5.3 Product Modification.....	62
5.4 Manufacturing and Production Tests.....	62
6 BIBLIOGRAPHY.....	62
APPENDIX A :.....	63
APPENDIX B : TOLERANCES	64
APPENDIX C : TOLERANCE LIMIT CALCULATIONS	65
APPENDIX D : FIGURES	66
APPENDIX E : SAMPLE LISTING.....	109

1 INTRODUCTION

1.1 Purpose

- 1.1.1 This standard states testing and certification criteria for automatic sprinklers for fire protection service.

NOTE: K14.0 (K200) and larger standard-coverage quick-response storage sprinklers (formerly ESFR sprinklers) are covered under FM Examination Standard 2008, while automatic sprinklers for residential fire protection service are covered under FM Examination Standard 2030.

- 1.1.2 Testing and certification criteria may include performance requirements, marking requirements, examination of manufacturing facility(ies), audit of quality assurance procedures, and a surveillance program.

1.2 Scope

- 1.2.1 This standard encompasses the design requirements, performance requirements, methods of test, and marking requirements for fusible element and glass bulb sprinklers in the following product categories and class numbers:

Table 1.2.1 Product Categories and Class Numbers

Class	Sprinkler Product Category
2001	K8.0 (K115) Non-Storage
2002	K2.8 (K40) Non-Storage
2005	In-Rack
2007	K11.2 (K160) Storage (formerly Control Mode Specific Application)
2009	K11.2 (K160) Storage (formerly Control Mode Density/Area)
2012	Sidewall Non-Storage
2013	Dry Non-Storage
2015	Flush, Recessed and Concealed Non-Storage
2016	K5.6 (K80) Upright Non-Storage
2017	K5.6 (K80) Pendent Non-Storage
2022	Extended Coverage Sprinklers
2023	K14.0 (K200) Storage (formerly Control Mode Density/Area)
2024	K16.8 (K240) Storage (formerly Control Mode)
2029	K25.2 (K360) Storage (formerly Control Mode)
2033	K14.0 (K200) Non-Storage Extended Coverage Horizontal Sidewall (formerly Metal Building Sprinklers)
2036	K19.6 (K280) Storage (formerly Control Mode)
2042	Corrosion Resistant Sprinkler Assemblies
2091	Sprinkler Guards

- 1.2.2 Other types of automatic sprinklers may be certified if they meet the requirements and intent of this standard. Sprinklers of unusual design may be subjected to special tests to determine their suitability.

1.3 Basis for Requirements

- 1.3.1 The requirements of this standard are based on experience, research and testing, and/or the standards of other organizations. The advice of manufacturers, users, trade associations, jurisdictions and/or loss control specialists was also considered.
- 1.3.2 The requirements of this standard reflect tests and practices used to examine characteristics of automatic sprinklers for the purpose of obtaining certification.

1.4 Basis for Certification

Certification is based upon satisfactory evaluation of the product and the manufacturer in the following major areas:

- 1.4.1 Examination and tests on production samples shall be performed to evaluate:
- the suitability of the product;
 - the performance of the product as specified by the manufacturer and required for certification;
 - the durability and reliability of the product.
- 1.4.2 An examination of the manufacturing facilities and audit of quality control procedures may be conducted to evaluate the manufacturer's ability to consistently produce the product which is examined and tested, and the marking procedures used to identify the product. Subsequent surveillance may be required by the certification agency in accordance with the certification scheme to ensure ongoing compliance.

1.5 Basis for Continued Certification

The basis for continual certification may include, the following based upon the certification scheme and requirements of the certification agency:

- production or availability of the product as currently certified;
- the continued use of acceptable quality assurance procedures;
- compliance with the terms stipulated by the certification;
- satisfactory re-examination of production samples for continued conformity to requirements;
- and
- satisfactory surveillance audits conducted as part of the certification agency's' product surveillance program.

1.6 Effective Date

The effective date of this examination standard mandates that all products tested for certification after the effective date shall satisfy the requirements of this standard.

The effective date of this standard is eighteen (18) months after the publication date of the standard for compliance with all requirements.

1.7 System of Units

Units of measurement used in this Standard are United States (U.S.) customary units. These are followed by their arithmetic equivalents in International System (SI) units, enclosed in parentheses. The first value stated

shall be regarded as the requirement. The converted equivalent value may be approximate. Conversion of U.S. customary units is in accordance with ANSI/IEEE/ASTM SI 10.

Two units of measurement (liters and bar), outside of, but recognized by SI, are commonly used in international fire protection and are used in this standard.

1.8 Normative References

The following documents are referred to in the text in such a way that some or all of their content constitutes requirements of this document. For dated references, only the cited edition applies.

IEEE/ASTM SI 10, American National Standard for Metric Practice

ANSI/ASME B1.20.1, *Pipe Threads, General Purpose, Inch*

ASTM B117, *Standard Practice for Operating Salt Spray (Fog) Apparatus*

ASTM E1, *Standard Specification for ASTM Liquid-In-Glass Thermometers*

ASTM E28, *Standard Test Methods for Softening Point of Resins Derived from Pine Chemicals and Hydrocarbons, by Ring-and-Ball Apparatus*

ASTM G36, *Standard Practice for Evaluating Stress-Corrosion-Cracking Resistance of Metals and Alloys in a Boiling Magnesium Chloride Solution*

1.9 Definitions

For purposes of this standard, the following terms apply:

Accepted

This term refers to installations acceptable to the authority enforcing the applicable installation rules. Acceptance is based upon an overall evaluation of the installation. Acceptance is not a characteristic of a product. It is installation specific. A product accepted for one installation may not be acceptable elsewhere.

Actual Delivered Density (ADD)

The rate at which the water is actually deposited from operating sprinklers onto the top horizontal surface of a burning storage array.

Amplitude

The maximum displacement of sinusoidal motion from position of rest to one-half of the total displacement.

Angle of Protection

For in-rack sprinklers, the "angle of protection" is that angle measured between the plane of the water shield and the line drawn from its outer edge to the lowest and outermost extremity of the actuator. For a link and lever sprinkler this would be the lowermost edge of the link or lever, measured with the link and lever assembly rotated 90° to the frame arm plane. For a center strut or glass bulb sprinkler, if a line drawn to the edge of the lower seat of the actuator or bulb rather than to the extremity of the actuator or bulb produces a larger angle, then that larger angle shall be the "angle of protection" for that sprinkler. See Figure D-1 for reference.

Assembly Load

The force which is applied to the sprinkler frame due to assembly of the operating parts plus the equivalent force resulting from the maximum rated inlet pressure.

Coated or Plated Sprinkler

A sprinkler which has a factory applied coating or plating for corrosion protection or decorative purposes.

Concealed Sprinkler

A sprinkler in which the entire body, including the operating mechanism, is above or behind a concealing plate, the margin of which is nearly flush to the ceiling or wall surface.

Conductivity (C-Factor)

A measure of the conductance between the sprinkler's heat responsive element and the other components of the sprinkler, including the fitting, expressed in units of (ft/s)^{1/2} or (m/s)^{1/2}.

Corrosion Resistant

Materials having resistance to corrosion equal to or exceeding that of bronze alloy having a minimum copper content of 80 percent.

Decorative Sprinkler

A sprinkler which is factory-painted or coated to improve its aesthetics. The coating is not considered a corrosion-resistant barrier.

Design Load

See Element Design Load.

Discharge Coefficient (K-Factor)

The coefficient of discharge, K, as expressed in the equation:

$$K = \frac{Q}{P^{1/2}}$$

Where Q is the flow in gallons per minute (gal/min), and P is the pressure in pounds per square inch (psi). Expressed in SI units: Q is the flow in liters per minute (L/min) and P is the pressure in bar. The discharge coefficient, therefore, has units of gal/min/(psi)^{1/2} or L/min/(bar)^{1/2}.

Dry-Type Sprinkler

A device consisting of a sprinkler permanently attached to an extension nipple which has a closure at the inlet end to prevent system water from entering the nipple until the sprinkler operates.

Element Design Load

The load actually applied on the operating element (fusible element or bulb) at the maximum rated inlet pressure.

Extended Coverage Sprinkler

A sprinkler with an intended area of coverage which exceeds the standard coverage area applicable to that type of sprinkler. Extended coverage Hazard Category 1-3 (HC-1 through HC-3) sprinklers are non-storage sprinklers that have an intended area of coverage between 225 and 400 sq ft (21 and 37 m²). Extended coverage storage sprinklers have an intended area of coverage between 100 and 196 sq ft (9 and 18 m²).

Standard Cartoned Expanded Plastic Commodity (Polystyrene Meat Trays)

A commodity product consisting of expanded polystyrene plastic food service trays (or meat trays) packaged in single-wall corrugated cartons. Each carton contains 200 plastic trays arranged in four stacks of 50 trays each. Typical trays weigh approximately 0.54 ounces (15 g) each, measure approximately 10.5 in. x 10.5 in. x 0.2 in thick. (27 cm x 27 cm x 0.5 cm) and consist of expanded foam plastic. Each carton measures 21 in. x 21 in. x 20 in. (53 cm x 53 cm x 51 cm) and weighs 8.9 lbs. (4.0 kg) when filled with the plastic trays. Each

pallet load consists of eight cartons placed in a 2 x 2 x 2 array upon a 42 in. x 42 in. x 5 in. (107 cm x 107 cm x 13 cm) two-way, slatted deck hardwood pallet.

Standard Class 2 Commodity

A commodity product that consists of three double-wall corrugated paper cartons. The dimensions for the inner, middle, and outer box are 40.3 in. x 40.3 in. x 37.8 in. (1.02 m x 1.02 m x 0.96 m), 41.0 in. x 41.0 in. x 39.1 in. (1.04 m x 1.04 m x 0.99 m), and 41.8 in. x 41.8 in. x 41.5 in. (1.06 m x 1.06 m x 1.05 m), respectively. Inside the cartons is a five-sided sheet metal liner, representing a non-combustible content. The cartoned liner is supported on an ordinary, two-way, slatted deck, hardwood pallet, measuring 42 in. x 42 in. x 5 in. (1.07 m x 1.07 m x 13 cm). The total combustible weight of the commodity is approximately 127.4 lb (57.8 kg); the corrugated containerboard weighs approximately 78.0 lb (35.4 kg), and the pallet weighs approximately 49.4 lb (22.4 kg).

Standard Uncartoned Expanded Plastic Commodity

A commodity product consisting of expanded polystyrene plastic food service trays (or meat trays) encased in plastic sleeves to form bundles. Typical trays weigh approximately 0.42 ounces (12 g) each, measure approximately 9.5 in. x 12.5 in. x 0.12 in. (24 cm x 32 cm x 0.3 cm) and consist of expanded foam plastic. Each bundle measures approximately 19.5 in. x 12 in. x 33 in. (50 cm x 30 cm x 84 cm) and contains two stacks of trays, weighing a total of 6.5 lbs. (2.9 kg). Each pallet load consists of eight tray bundles placed in a 2 x 1 x 4 array upon a 42 in. x 42 in. x 5 in. (107 cm x 107 cm x 13 cm) two-way, slatted deck hardwood pallet.

Standard Cartoned Unexpanded Plastic Commodity

A commodity product of cartoned Group A unexpanded plastic, consisting of rigid crystalline polystyrene jars (empty, 16 fl. oz. size) packaged in compartmented, single wall, corrugated cartons measuring 21 in. x 21 in. x 20 in. (53 cm x 53 cm x 51 cm). Jars are arranged in five layers, 25 per layer for a total of 125. Each pallet load consists of eight cartons, arranged in a 2x2x2 array upon a 42 in. x 42 in. x 5 in. (107 cm x 107 cm x 13 cm) two-way, slatted deck hardwood pallet.

Standard Igniter

A standard igniter is the ignition source used for all full scale fire tests (see Sections 4.39 - 4.46). A standard igniter consists of either 2 or 4 half-igniters, depending on the ignition location. When ignition is located at the intersection of the longitudinal and center transverse flue spaces of a double row rack (i.e., centered in the main array), 4 half igniters are used. When ignition is located within the center transverse flue space and positioned 2 ft (0.6 m) to one side of the longitudinal flue of a double row rack (i.e., offset within the main array), 2 half igniters are used. Each half-igniter consists of a 3 in. diameter by 3 in. long (76 mm x 76 mm) cylinder of rolled cellucotton, soaked with 4 fluid ounces (118 ml) of gasoline, then sealed in a polyethylene plastic bag. Igniters are prepared no more than 15 minutes prior to testing. They are positioned at the base of the bottom tier pallet loads, lit with a propane torch to signal the start of the test, and the fires are allowed to develop naturally.

Flush Sprinkler

A sprinkler in which essentially all of the body, with the exception of the heat responsive assembly, is mounted above the lower plane of the ceiling.

Fusible Element Sprinkler

A sprinkler that opens under the influence of heat by the melting of a component.

Glass Bulb Sprinkler

A sprinkler that opens under the influence of heat by bursting of a glass bulb due to pressure resulting from expansion of the enclosed fluid.

Hang-Up (Lodgment)

A malfunction in the operation of a sprinkler which, when operated under a typical system water pressure, experiences the lodging of an operating part (cap, gasket, lever, etc.) on or between the frame, deflector and/or compression screw, adversely affecting the water distribution for a period in excess of 60 seconds. A momentary hesitation of an operating part to clear itself from temporary contact with the frame, deflector and/or compression screw does not constitute a hang-up.

Hazard Category 1 (HC-1) (formerly Light Hazard Occupancy)

A non-storage occupancy in which the quantity and/or combustibility of contents is low and fires with relatively low rates of heat release are expected.

Hazard Category 2 (HC-2) (formerly Ordinary Hazard Group 1 Occupancy)

A non-storage occupancy in which the quantity and/or combustibility of contents is moderate.

Hazard Category 3 (HC-3) (formerly Ordinary Hazard Group 2 Occupancy)

A non-storage occupancy in which the quantity and/or combustibility of contents is high.

Heat Responsive Element

The component of a sprinkler assembly that, when subjected to the influence of heat, ruptures, bursts or otherwise functions, causing water to be discharged through the sprinkler orifice.

In-Rack Sprinkler

A sprinkler intended for use in racks or beneath open gratings, which is equipped with a shield mounted above the heat responsive element to protect it from water discharge from nearby sprinklers at higher elevations. In-rack sprinklers are also commonly known as rack storage or intermediate level sprinklers. The design of an in-rack sprinkler may consist of a standard spray (upright or pendent) sprinkler equipped with a shield.

Leak Point

The pressure at which leakage of water in excess of one drop per minute occurs.

Maximum Service Pressure

The maximum rated working pressure of a sprinkler, typically 175 psi (12.1 bar).

Non-Storage Sprinkler

A sprinkler that has been categorized as acceptable for protecting non-storage-type occupancies and/or other occupancy hazards characterized by low to moderate heat-release rate fire. Generally, extended coverage sprinklers with nominal discharge coefficients less than $25.2 \text{ gal/min}/(\text{psi})^{1/2}$ ($360 \text{ L/min}/(\text{bar})^{1/2}$) and standard coverage sprinklers with nominal discharge coefficients less than $11.2 \text{ gal/min}/(\text{psi})^{1/2}$ ($160 \text{ L/min}/(\text{bar})^{1/2}$) are categorized as non-storage sprinklers. NOTE: Storage sprinklers may also be used to protect non-storage occupancies unless indicated otherwise.

Operating Temperature

The temperature, in degrees Fahrenheit (°F) or Celsius (°C), at which the heat responsive element of a sprinkler operates when subjected to a controlled rate-of-temperature-rise liquid bath.

Orientation, Best Case

When testing sprinklers for sensitivity in the plunge tunnel, the orientation of a sprinkler which results in the fastest operating time, or the lowest Response Time Index (RTI). Typically, this orientation is one in which

the sprinkler waterway axis and the plane of the frame arms are both perpendicular to the air flow and, in the case of non-symmetric elements, the heat responsive element is upstream of the frame arms.

Orientation, Worst Case

For use in this standard, when testing sprinklers for sensitivity in the plunge tunnel, the worst case orientation is a given angular offset from the orientation which results in the slowest operating time, or the highest Response Time Index (RTI). For standard response sprinklers this angular offset is 15 degrees. The angular offset for quick response sprinklers is 25 degrees.

Orifice

The opening in a sprinkler body through which the water is discharged.

Pendent Sprinkler

A sprinkler designed such that the water exiting the orifice is directed downward against the deflector.

Quick Response Sprinkler

A sprinkler having a Response Time Index (RTI) and Conductivity factor (C) combination which fall into the indicated area on the graph in Figure D-2. Generally, this is a sprinkler having an RTI equal to or less than $90 \text{ (ft}\cdot\text{s)}^{1/2}$ [$50 \text{ (m}\cdot\text{s)}^{1/2}$] and a C-factor equal to or less than $1.81 \text{ (ft/s)}^{1/2}$ [$1.0 \text{ (m/s)}^{1/2}$], when the sprinkler is tested in the best case orientation. For recessed, flush and concealed sprinklers, the criteria outlined in Section 4.29 shall be met, as appropriate.

Recessed Sprinkler

A sprinkler in which part or most of the body of the sprinkler, other than the part which connects to the piping, is mounted within a recessed housing with the plane of the orifice above the plane of the ceiling, or behind the plane of the wall on which the sprinkler is mounted.

Response Time Index (RTI)

A measure of sprinkler sensitivity expressed as $RTI = \tau(u)^{1/2}$ where τ is the time constant of the heat responsive element in units of seconds, and u is the gas velocity expressed in feet per second (or meters per second). The quantity τ relates the properties of the heat responsive element and the heated gas flow. RTI can be used to predict the response of a sprinkler in fire environments defined in terms of gas temperature and velocity versus time. RTI is expressed in units of $(\text{ft}\cdot\text{s})^{1/2}$ or $(\text{m}\cdot\text{s})^{1/2}$.

Service Pressure

The working hydrostatic pressure of a sprinkler system.

Sidewall Sprinkler

A sprinkler intended for installation near a wall and ceiling interface and designed to discharge water outward and onto adjacent walls. Sidewall sprinklers may be designed such that the orifice is oriented in either the horizontal or vertical plane.

Standard Response Sprinkler

A sprinkler having a Response Time Index (RTI) and C-factor combination which fall into the indicated area on the graph in Figure D-2. Generally, this is a sprinkler having an RTI between 145 and $635 \text{ (ft}\cdot\text{s)}^{1/2}$ [80 and $350 \text{ (m}\cdot\text{s)}^{1/2}$] and a C-factor equal to or less than $3.62 \text{ (ft/s)}^{1/2}$ [$2.0 \text{ (m/s)}^{1/2}$], when the sprinkler is tested in the best case orientation. Recessed, flush and concealed sprinklers shall meet the criteria outlined in Sections 4.28 [Sensitivity - Response Time Index (RTI)] or 4.29 [Sensitivity (Recessed, Flush, and Concealed Types)], as appropriate.

Standard Sidewall Sprinkler

A non-storage sidewall (horizontal or vertical) sprinkler having a nominal discharge coefficient of 5.6 or 8.0 gal/min/(psi)^{1/2}. Extended coverage sprinklers are excluded from the standard sidewall sprinkler category.

Standard Spray Sprinkler

An upright or pendent non-storage sprinkler having a nominal discharge coefficient of 2.8, 5.6 or 8.0 gal/min/(psi)^{1/2} (40, 80 or 115 L/min/(bar)^{1/2}). An upright or pendent storage sprinkler having a nominal discharge coefficient of 11.2, 14.0, or 16.8 gal/min/(psi)^{1/2} (160, 200 or 240 L/min/(bar)^{1/2}). Extended coverage sprinklers are excluded from the standard spray sprinkler category.

Storage Sprinkler

A sprinkler acceptable for protecting storage-type occupancies and/or any other occupancy hazards characterized by high heat-release rate fires. Generally, extended coverage sprinklers with nominal discharge coefficients greater than or equal to 25.2 gal/min/(psi)^{1/2} (360 L/min/(bar)^{1/2}) and standard coverage sprinklers with nominal discharge coefficients greater than or equal to 11.2 gal/min/(psi)^{1/2} (160 L/min/(bar)^{1/2}) are categorized as storage sprinklers. In-rack sprinklers are also classified as storage sprinklers since they are used almost exclusively in storage racks.

Strutting

Partial fracture of a glass bulb or partial rupture of a fusible element which does not result in sprinkler operation.

Upright Sprinkler

A sprinkler designed such that the water exiting the orifice is directed upward against the deflector.

Weep Point

The pressure at which any visible leakage of water is detected.

2 GENERAL INFORMATION

2.1 Product Information

An automatic sprinkler is a thermo-sensitive device designed to react at a predetermined temperature by releasing a stream of water and distributing it with a specified pattern and flow rate over a designated area when installed on the appropriate sprinkler piping.

In order to meet the intent of this standard, sprinklers shall be examined on a model-by-model, type-by-type, manufacturer-by-manufacturer, and plant-by-plant basis. This is predicated on the basis that the manufacturing of sprinklers requires sufficient skill in its execution that identical designs, fabricated in identical materials by different manufacturers or, even by different plants of the same manufacturer, have been seen to perform differently in testing. Sample sprinklers, selected in conformance to this criterion, shall satisfy all of the requirements of this standard.

2.2 Certification Application Requirements

The manufacturer shall provide the following preliminary information with any request for certification consideration:

- a complete list of all models, types, sizes, and options for the products or services being submitted for certification consideration;
- a complete set of manufacturing drawings, general assembly drawings, materials list(s), assembly load calculations, anticipated marking format, brochures, sales literature, specification sheets, installation, operation and maintenance procedures, and;
- the number and location of manufacturing facilities.

All documents shall identify the manufacturer's name, document number or other form of reference, title, date of last revision, and revision level. All documents shall be provided with English translation.

2.3 Requirements for Samples for Examination

2.3.1 Following authorization of a certification examination, the manufacturer shall submit samples for examination and testing based on the following:

- Sample requirements to be determined by the certification agency

2.3.2 Requirements for samples may vary depending on design features, results of prior or similar testing, and results of any foregoing tests.

2.3.3 The manufacturer shall submit samples representative of production. Any decision to use data generated using prototypes is at the discretion of the certification agency.

2.3.4 The manufacturer shall provide any special test fixtures, such as those which may be required to evaluate the strength of heat responsive elements, requested by the certification agency to evaluate the sprinklers.

3 GENERAL REQUIREMENTS

3.1 Review of Documentation

- 3.1.1 During the initial investigation and prior to physical testing, the manufacturer's specifications and details shall be reviewed to assess the ease and practicality of installation and use. The certification examination results may further define the limits of the final certification.

3.2 Physical or Structural Features

- 3.2.1 All materials used in automatic sprinklers shall be suitable for the intended application. Sprinkler parts exposed to water shall be constructed of corrosion resistant materials. When unusual materials are used, special tests, beyond those specified in this standard, may be necessary to verify their suitability.
- 3.2.2 Stampings shall show no cracking or splitting and be free of burrs.
- 3.2.3 Deflectors of sprinklers shall be securely attached.
- 3.2.4 Sprinklers shall be designed and manufactured such that adjustment of the assembly load or replacement of operating parts shall not be possible without visible permanent damage to the device.
- 3.2.5 All connections shall be suitable for use with fittings having tapered pipe threads which conform to a national or internationally recognized standard. Sprinklers which are to be sold in the United States shall be threaded to suit fittings manufactured in accordance with ANSI/ASME B1.20.1, *Standard for Pipe Threads*, per Table 3.2.5.

Table 3.2.5. Threaded Connections

<i>Nominal K-Factor gal/min/(psi)^{1/2}</i>	<i>U.S. Nominal Thread Size, in.</i>
2.8	1/2 or 3/4
5.6	1/2 or 3/4
8.0	1/2 or 3/4
11.2	1/2 or 3/4
14.0	3/4
16.8	3/4
19.6	1
25.2	1

- 3.2.6 Connections incorporating thread sizes larger than those stated in Section 3.2.5 are permitted for special purpose sprinklers such as dry, flush and adjustable types.
- 3.2.7 Sprinklers having water passageways with cross-sectional dimensions less than 3/8 in. (9.5 mm) may necessitate the use of individual or system strainers per appropriate installation standards. At the sole discretion of the certification agency, sprinklers incorporating such passages shall require a statement in various publications (i.e. manufacturer's literature, certification reports, etc.) referring to the size of the openings and indicating their need for use with appropriate strainers.
- 3.2.8 A special wrench, facilitating installation, shall be available from the manufacturer and provided to the certification agency for evaluation. If installation using a common wrench is permitted by the manufacturer, such wrench shall not easily damage the sprinkler. If a common wrench is to be used for installation, the possibility of wrench slippage exists with possible subsequent damage to the sprinkler and the possibility of hidden damage so as to render the sprinkler inoperative. For this reason, sprinklers permitted by the manufacturer to be installed with a common wrench shall meet the following requirement: the minimum length of the wrench flats shall be equal to the distance between the flats of the sprinkler.

- 3.2.9 All operating parts shall have ample clearance with near zero possibility of binding or wedging. An analysis of the design drawings may be conducted to evaluate the worst combination of tolerances in parts so as to assess the possibility of such malfunction.
- 3.2.10 Plated or coated-sprinklers shall be subjected to additional evaluation and testing, beyond that specified in this standard, to verify the integrity of their mechanical and operational properties and marking clarity. Factory plating or coating of sprinklers shall not change the mechanical or operational properties of the sprinkler beyond acceptable limits stated in this standard.
- 3.2.11 Finishes such as plating, decorative painting, or coating shall not be applied to sprinklers by anyone other than the sprinkler manufacturer, or vendor, at the time of manufacture. Examination of sprinklers with such finishes or coatings is required. Such sprinklers shall meet all requirements for their respective class(es) of sprinkler(s).
- 3.2.12 Ornamental sprinklers such as concealed types may have factory-painted cover plates, if the painted plates have been tested as part of the sprinkler evaluation.
- 3.2.13 Inlet protrusion into the fitting shall not adversely affect the flow of water through the fitting.
- 3.2.14 Certification of specific sprinkler types is restricted according to maximum nominal operating temperature rating as follows:

Table 3.2.14. Maximum Nominal Temperature Rating by Sprinkler Type

<i>Sprinkler Type</i>	<i>Maximum Nominal Temperature Rating</i>	
	<i>°F</i>	<i>(°C)</i>
Standard Sidewall (Horizontal and Vertical)	300	(149)
Flush, Recessed and Concealed (Standard and Quick Response)	225	(107)
Extended Coverage Hazard Category 1 (Flush, Recessed and Concealed Types)	165	(74)
Extended Coverage Hazard Category 1 (Other Types)	175	(79)

- 3.2.15 An open (operated) sprinkler that is identical in design and construction to a certified automatic sprinkler, less its operating components, is considered to be certified.

3.3 Markings

- 3.3.1 All sprinklers shall be marked in accordance with one of the two marking schemes described in 3.3.1.1 and 3.3.1.2. The manufacturer may use either one or both of the schemes and shall notify the certification agency prior to making any marking changes on the sprinklers.

- 3.3.1.1 The following marking scheme is intended to meet the National Fire Protection Association (NFPA) marking requirements adopted in 1999 and effective January 1, 2001.

Sprinklers shall be permanently marked with a one- or two-character manufacturer symbol, followed by three or four numbers. This marking, or sprinkler identification number (SIN) shall uniquely identify the sprinkler based upon the following:

- Orifice size or shape
- Deflector type or orientation
- Pressure rating
- Thermal sensitivity (i.e. response classification)

The manufacturer shall be assigned the one- or two-character manufacturer symbol by contacting the International Fire Sprinkler Association (<http://www.firesprinkler.global>).

The manufacturer shall not place this identification mark on any other product.

In addition to the SIN, the following shall be displayed on a non-operating part of the sprinkler:

- Nominal temperature rating (in °F or °C at a minimum);
- Year of manufacture (Note: sprinklers manufactured in the first 6 months or last 3 months of a calendar year may be marked with the previous or following year respectively, as the year of manufacture);
- The certification agency's mark of conformity.

Optionally, the following additional information may be displayed on a non-operating part of the sprinkler:

- Manufacturer's name or identifying symbol (logo);
- Model designation (see Section 3.3.2 below);
- Nominal K-factor per Table 4.15.1 (in English units: gal/min/(psi)^{1/2});
- The word "PENDENT" (or the letters "SSP"), the word "UPRIGHT" (or the letters "SSU"), or other designation to indicate type or orientation, as appropriate;

- 3.3.1.2 In lieu of the marking requirements of Section 3.3.1.1, sprinklers shall be permanently marked on a non-operating component with the following:
- Manufacturer's name or identifying symbol (logo);
 - Model designation (see Section 3.3.2 below);
 - Nominal K-factor per Table 4.15.1 (in U.S. customary units: gal/min/(psi)^{1/2});
 - The word "PENDENT" (or the letters "SSP" or "SP"), the word "UPRIGHT" (or the letters "SSU" or "SU"), or other designation to indicate type or orientation, as appropriate;
 - Nominal temperature rating (in °F or °C at a minimum);
 - Year of manufacture (Note: sprinklers manufactured in the first 6 months or last 3 months of a calendar year may be marked with the previous or following year respectively, as the year of manufacture);
 - Quick response sprinklers shall be marked with the words "Quick Response" or the initials "QR";
 - The certification agency's mark of conformity.
- 3.3.2 Regardless of the marking scheme utilized, the sprinkler identification number (SIN), model designation, and/or type identification shall correspond with the manufacturer's catalog designation and shall uniquely identify the sprinkler as certified. The manufacturer shall exercise control of this mark as specified by the certification agency and the certification scheme.
- 3.3.3 For fusible type sprinklers, the operating temperature, or the temperature rating color code, as defined in Table 3.3.5, shall appear on a visible area of the fusible element or an associated operating component.
- 3.3.4 If a manufacturer produces sprinklers with the same model designation at more than one facility, each sprinkler shall bear a distinctive marking on a non-operating part to identify it as the product of a particular location.
- 3.3.5 All sprinklers, with the exception of glass bulb type sprinklers, shall be color coded in accordance with Table 3.3.5. Paint of the correct color shall be applied to at least 50 percent of each frame arm surface. This application of paint shall be visible on the sprinkler from all directions. The color identification for coated, plated and recessed sprinklers may be a dot on the top of the deflector,

the color of the coating material or colored frame area. This dot shall be visible from a distance of 3 feet (0.9 m).

Table 3.3.5. Temperature Ratings, Classifications, and Color Code

Nominal Temperature¹ Rating Range		Maximum Ambient Temperature at Sprinkler Level		Temperature Classification	Sprinkler Frame Color Code
°F	(°C)	°F	(°C)		
135 to 170	(57 to 77)	100	(38)	Ordinary	None or Black
175 to 225	(79 to 107)	150	(66)	Intermediate	White
250 to 300	(121 to 149)	225	(107)	High	Blue
325 to 375	(163 to 191)	300	(149)	Extra High	Red
400 to 475	(204 to 246)	375	(191)	Very Extra High	Green
500 to 575	(260 to 302)	475	(246)	Ultra High	Orange
650	(343)	625	(329)	Ultra High	Orange/Tag

Note: ¹ Certified sprinklers shall have a specific temperature rating within the range.

- 3.3.6 Bulb type sprinklers shall comply with the bulb color designation shown in Table 3.3.6. The bulb fluid color shall be considered a suitable method of temperature identification in addition to permanent marking elsewhere on the sprinkler.

Table 3.3.6. Temperature Ratings and Bulb Color Codes

Nominal Temperature Rating		Bulb Color Code
°F	(°C)	
135	(57)	Orange
155	(68)	Red
175	(79)	Yellow
200, 225	(93, 107)	Green
250, 286	(121, 141)	Blue
325, 360	(162, 182)	Mauve
400 to 650	(204 to 343)	Black

- 3.3.7 For all concealed sprinklers, the cover plate shall be marked with the words "Do Not Paint" in characters at least 1/8 in. (3.2 mm) in height.
- 3.3.8 Horizontal sidewall sprinklers shall include the word "Top" on the deflector to indicate orientation.
- 3.3.9 Vertical sidewall sprinklers shall bear an arrow indicating the direction of flow and the word "flow".
- 3.3.10 Factory plated sprinklers shall be identified as such with a distinctive marking so as to distinguish the product from unauthorized field plating.
- 3.3.11 For factory decorative-painted (coated) sprinklers, some portion of the sprinkler shall remain unpainted and readily visible from a minimum of 1 foot (0.3 m). This would allow a means to determine if the sprinkler were repainted in the field. Field painting is prohibited.

- 3.3.12 For bulb-type sprinklers, the manufacturer shall place a distinctive mark on a non-operating part of the sprinkler to denote the bulb manufacturer if more than one source is used in a given design.
- 3.3.13 With the exception of wax-coated sprinklers, all markings shall be permanent and visible from a distance of 3 feet (0.9 m). The markings shall remain visible through any factory-applied plating or decorative coating.

3.4 Manufacturer's Installation and Operation Instructions

The manufacturer shall provide the user with adequate instructions for proper installation with each shipment. Sprinklers shall be installed and maintained in accordance with applicable installation rules. Field modification, such as replacing a component on a sprinkler, plating, or painting, is prohibited.

3.5 Calibration

- 3.5.1 Each piece of equipment used to verify the test parameters shall be calibrated within an interval determined on the basis of stability, purpose, and usage. A copy of the calibration certificate for each piece of test equipment is required. The certificate shall indicate that the calibration was performed against working standards whose calibration is certified and traceable to an acceptable reference standard and certified by an ISO/IEC 17025 accredited calibration laboratory. The test equipment shall be clearly identified by label or sticker showing the last date of the calibration and the next due date. A copy of the service provider's accreditation certificate as an ISO/IEC 17025 accredited calibration laboratory should be available.
- 3.5.2 When the inspection equipment and/or environment is not suitable for labels or stickers, other methods such as etching of control numbers on the measuring device are allowed, provided documentation is maintained on the calibration status of this equipment.

4 PERFORMANCE REQUIREMENTS

Test Pressures

All test pressures are based on the maximum rated working pressure of 175 psi (12.1 bar). Other pressures will be considered at the discretion of the certification agency.

4.1 Examination

4.1.1 Requirement

The sprinklers shall conform to the manufacturer's drawings and specifications and to the certification agency's requirements.

4.1.2 Test/Verification

A sample or samples shall be examined and compared to drawings and specifications. It shall be verified that the sample conforms to the physical and structural requirements described in Section 3, General Requirements.

4.2 Assembly Load/Frame Strength

4.2.1 Requirement

The frame of a sprinkler shall be capable of withstanding twice the assembly load without sustaining permanent elongation or deformation in excess of 0.2 percent of the distance between the load bearing parts of the sprinkler.

4.2.2 Tests/Verification

- A. Fifteen previously untested sprinklers shall be individually tested to determine the assembly load. With the threaded portion of the sprinkler restrained from movement, the heat responsive element of the test sample shall be removed and the negative axial deflection of the frame, resulting from the release of the assembly shall be recorded. Deflection measurements shall be made using an indicator capable of reading to a precision of 0.00001 in. (0.00025 mm). A force necessary to return the deflection of the frame to the original zero position shall then be applied and the value of the force recorded.
- B. Each of these sprinklers shall then be subjected momentarily (for 1 to 5 seconds) to twice the sum of the force recorded in Section 4.2.2A, plus the force applied to the sprinkler as a result of the maximum rated working pressure [typically 175 psi (12.1 bar)]. The amount of permanent set after the load application shall be determined. The percentage of permanent frame elongation shall be calculated using the minimum distance between the load bearing points, determined to the nearest 0.001 in. (0.03 mm), from the plane of the sprinkler orifice to the center of the compression bearing surface of the sprinkler.
- C. Alternate Assembly Load Test Method for Sprinklers with a Belleville Washer Type Seal:

The following test method may be employed for determining the assembly load of sprinklers incorporating a Belleville washer type seal (i.e., coned-disc spring or cupped spring washer) as it has been determined to provide results equivalent to or more accurate than the method described in Section 4.2.2A.

Mount an assembled sprinkler into a solid fixture and mark the pipcap/seat, spring, and frame for orientation purposes. This enables the components to be reassembled in their original positions. Set a dial indicator on the bottom of the sprinkler, through the waterway, and in contact with the bottom of the pipcap/seat. Zero the indicator gage and operate the heat responsive element using pliers or by another suitable mechanical means. Remove the compression screw from the sprinkler, if necessary, then align and re-assemble the operating components (spring and pipcap/seat) in the waterway. Set a hydraulic ram with a load cell (or other suitable means of load

application and measurement) on top of the sprinkler and employ a suitable fixture such that load can be applied to the pipcap/seat. Apply a load to the pipcap/seat and compress the spring until the dial indicator returns to zero. Wait ten minutes, then record the reported load as the assembly load.

NOTE: If the alternate method is used to determine assembly load, a separate frame strength test must still be performed as described in Section 4.2.2B.

4.3 Strength of Heat Responsive Element

4.3.1 Requirement

- A. A heat responsive element of the fusible type shall be (1) capable of sustaining a load 15 times its maximum design load for a period of 100 hours or (2) demonstrate the ability to sustain the maximum element design load when tested in accordance with Section 4.3.2A2.
- B. For a heat responsive element of the glass bulb type, the lower tolerance limit of bulb strength shall be greater than two times the upper tolerance limit of sprinkler assembly load based on calculations with a degree of confidence of 0.99 (99 percent). Calculations shall be based on the Normal or Gaussian Distribution except where another distribution can be shown to be more applicable due to manufacturing or design factors. The method for calculating the upper and lower tolerance limits is shown in Appendix C.

4.3.2 Tests/Verification

A. Heat Responsive Element of the Fusible Type

1. Fifteen samples shall be loaded with a weight representing the equivalent of 15 times the design load. All samples must remain undamaged after sustaining this load for a period of 100 hours.
2. Fusible type heat responsive elements which cannot pass the test described in 4.3.2A1 shall meet the following requirements. Sample fusible type heat-responsive elements shall be subjected to loads in excess of the design load which will produce failure both within and after 1000 hours. The test samples shall be maintained at an environmental temperature of 70 ± 5 °F (21 ± 2.6 °C). At least 15 samples shall be loaded to various degrees in order to establish a basis of time to failure as a function of load. Failures which are not related to the solder bond shall be disregarded. A least squares, full logarithmic regression curve shall be plotted from which both the load to failure at 1 hour (L_o) and the load to failure at 1000 hours (L_m) shall be determined. The actual maximum design load on the fusible element, as determined using the upper tolerance limit of assembly load from Section 4.2.2A, shall be less than or equal to the maximum permitted design load (L_d) determined in the expression:

$$L_d = 1.02 \frac{L_m^2}{L_o}$$

Where:

L_d = Maximum permitted design load for the heat responsive element

L_m = Load resulting in failure at 1000 hours

L_o = Load resulting at failure in 1 hour

3. Where physical limitations of the fusible element prevent the application of the loads described in Section 4.2.2A, alternate methods of determining the adequacy of the design shall be developed to ensure that such elements should not fail during the anticipated life span.

B. Heat Responsive Element of the Bulb Type

The results of the assembly load test, Section 4.2.2A, shall form the basis for calculating the upper tolerance limit of the sprinkler assembly load. The lower tolerance limit for bulb strength shall be determined using the results obtained from subjecting a minimum of 25 sample bulbs to an increasing load until the bulbs fail. Each test shall be conducted with the bulb mounted in hardened steel inserts with seating surfaces having dimensions which conform to the actual mating components of the sprinkler. The inserts shall have a hardness within the range Rockwell C 38-50 (see Figure D-3). They shall be provided by the manufacturer each time the test is specified. The load shall be applied at a rate of compression not exceeding 0.05 in./min (1.27 mm/min). The results obtained from the two sets of data shall be utilized for the tolerance limit calculations as described in Appendix C, Tolerance Limit Calculations.

4.4 Leakage

4.4.1 Requirement

Sprinklers shall not weep or leak at, or below, 500 psi (34.5 bar) hydrostatic pressure and shall not leak at 30 psi (2.1 bar) pneumatic pressure. Additionally, dry type sprinklers shall not weep or leak at the junction of the inlet and the extension nipple when that connection is subjected to external pneumatic pressures from 0 to 15 psi (0 to 1.0 bar).

4.4.2 Tests/Verification

- A. Hydrostatic Leakage - Ten previously untested sprinklers shall be individually subjected to a slowly rising hydrostatic pressure. The pressure shall be increased from 0 to 500 psi (0 to 34.5 bar), at a rate not to exceed 300 psi (20.7 bar) per second, and maintained at 500 psi (34.5 bar) for 1 minute.
- B. Pneumatic Leakage - Four previously untested sprinklers shall be individually conditioned at $-20 \pm 10^{\circ}\text{F}$ ($-29 \pm 6^{\circ}\text{C}$) for 24 hours. Each sample shall be pneumatically pressurized to 30 ± 2 psi (2.1 ± 0.1 bar) and immersed in glycol liquid conditioned to $-20 \pm 10^{\circ}\text{F}$ ($-29 \pm 6^{\circ}\text{C}$), and observed for 5 minutes.
- C. Pneumatic Leakage – Dry Sprinkler Inlet (Dry Sprinklers Only) - 5 previously untested sprinklers shall be individually installed on a test apparatus which isolates the junction of the inlet and extension nipple (see Figure D-4). Each sample shall be immersed in water, pneumatically pressurized to 15 ± 2 psi (1.0 ± 0.1 bar), and observed for 5 minutes for evidence of leakage.

4.5 Hydrostatic Strength

4.5.1 Requirement

Sprinklers shall be capable of withstanding, without rupture, an internal hydrostatic pressure of up to 700 psi (48.3 bar) for a period of 1 minute.

4.5.2 Tests/Verification

If all samples comply with the requirements of Section 4.4.2A, each sample shall be further subjected to a gradually increasing hydrostatic pressure to 700 psi (48.3 bar) at a rate not to exceed 300 psi (20.7 bar) per second. The test pressure shall be maintained for 1 minute. If leakage at the orifice prevents testing at 700 psi (48.2 bar), the maximum attainable test pressure shall be maintained for 1 minute. Leakage at the orifice above a hydrostatic pressure of 500 psi (34.4 bar) shall be deemed acceptable.

4.6 30-Day Leakage

4.6.1 Requirement

Sprinklers shall not weep or leak when subjected to an internal hydrostatic pressure of 300 psi (20.7 bar) for a continuous period of 30 days. Following this test period, the samples shall not weep or leak at, or below, 500 psi (34.5 bar) when tested in accordance with Section 4.4.2A (Hydrostatic Leakage). The samples shall also show no evidence of distortion or physical damage.

4.6.2 Tests/Verification

Five previously untested samples shall be hydrostatically tested to confirm that there are no weep or leak points at, or below, 500 psi (34.5 bar). The samples shall then be installed on a water-filled test apparatus which is to be maintained at ambient temperature and at a constant pressure of 300 psi (20.7 bar) for 30 days. The samples shall be examined weekly during the test period for evidence of leakage at the seal.

Following this test, the samples shall be subjected to the post-tests detailed above.

4.7 Water Hammer

4.7.1 Requirement

Sprinklers shall be capable of withstanding 100,000 applications of a pressure surge from approximately 50 to 500 psi (3.4 to 34.5 bar) without leakage, distortion, or physical damage. Following satisfactory completion of this test, the samples shall not weep or leak at, or below, 500 psi (34.5 bar) when tested in accordance with Section 4.4.2A (Hydrostatic Leakage). The samples shall also show no evidence of distortion or physical damage. Subsequently, the samples shall exhibit positive operation and release of all operating parts at the minimum operating pressure stated in Table 4.25.1 when tested in accordance with Section 4.25.2 (Minimum Operating Pressure).

4.7.2 Tests/Verification

Five previously untested samples shall be hydrostatically tested to confirm that there are no weep or leak points at, or below, 500 psi (34.5 bar). They shall then be installed on a water-filled manifold and subjected to changes in pressure from approximately 50 +0/-50 to 500 +0/-50 psi (3.4 +0/-3.4 to 34.5 + 0/-3.4 bar) for 100,000 +1,000/-0 cycles. The cycle period shall be between 1 and 4 seconds. Observations shall be made for evidence of leakage at least twice a day during the test period.

Following this test, the samples shall be subjected to the post-tests detailed above.

4.8 Operating Temperature (Liquid Bath)

4.8.1 Requirement

Sprinklers and cover plates having nominal temperature ratings less than 400°F (204°C) shall have an actual operating temperature within ± 3.5 percent of the marked nominal temperature rating, when immersed in a constant rate-of-temperature-rise liquid bath. Sprinklers and cover plates with nominal temperature ratings of 400°F (204°C) or greater shall meet the requirements stated above, or shall have an actual operating temperature within + 107 percent of the marked nominal temperature rating (i.e. -0/+7 percent).

4.8.2 Tests/Verification

Ten previously untested sprinklers shall be immersed in a vessel containing a liquid as specified in Table 4.8.2.

Table 4.8.2. Liquid Bath Conditions

Nominal Temperature Rating of Sprinkler		Bath Liquid	Maximum Rate of Temperature Rise	
°F	(°C)		°F/min	(°C/min)
0 - 175	(0 - 79)	Water	0.8	(0.4)
176 - 360	(80 - 182)	Glycerin	0.5	(0.3)
361 +	(183 +)	Vegetable Oil	0.5	(0.3)

The sprinklers shall be placed on a grate or rack suspended above the bottom of the vessel. The liquid level shall not exceed 1 in. (25.4 mm) above the top of the sprinkler, and whenever possible, shall not exceed 1.5 in. (38.1 mm) above the top of the heat responsive element. The vessel shall be provided with a source for heating the liquid, a means to agitate the liquid, and a device to measure the temperature of the liquid (see Figure D-5 for a typical test set-up). The liquid shall be agitated at a constant rate of 200 ± 10 rpm via a paddle measuring 4 in. (100 mm) long by 0.8 in. (20 mm) high. The device used to measure the temperature of the liquid shall be calibrated in accordance with the ASTM E1, *Standard Specification for ASTM Liquid-In-Glass Thermometers*, or the equivalent. It shall be immersed such that readings are taken at the same depth as the sprinkler heat responsive element.

The temperature of the bath shall be raised until the liquid is $20 \pm 2^\circ\text{F}$ ($11.1 \pm 1.1^\circ\text{C}$) below the nominal temperature rating of the sprinkler. The temperature rise shall then be controlled at a rate not exceeding that specified in Table 4.8.2 until operation of all sprinklers occurs. If one or more sprinklers fails to operate at, or below, the maximum temperature as stated in Section 4.8.1, the rate of rise shall continue to be controlled until all the sprinklers have operated, or until the bath reaches a temperature ten percent above the nominal temperature rating of the sprinklers, at which point the test shall be terminated. The temperature of the liquid bath at the time of operation shall be recorded for each sprinkler.

Partial fracture of a glass bulb or partial rupture of a fusible element which does not result in sprinkler operation, i.e., strutting, shall necessitate an additional test (Air Bath Test, Section 4.9) in order to verify proper operation of the sprinkler in air.

4.9 Air Bath

4.9.1 Requirement

The heat responsive element of a sprinkler shall operate properly when subjected to a constant rate-of-temperature-rise air bath.

NOTE: the air bath test is required only if strutting is observed during a liquid bath test.

4.9.2 Tests/Verification

Fifty previously untested sprinklers shall be placed on their threaded inlets in a programmable oven circulating air at ambient temperature. The temperature in the oven shall be steadily raised to $20 \pm 2^\circ\text{F}$ ($11.1 \pm 1.1^\circ\text{C}$) below the nominal temperature rating of the sprinklers over a 20 minute period. Once this temperature is reached, the oven shall be maintained at constant temperature for a period of 60 ± 5 minutes. The temperature shall then be raised at a constant rate of $1 \pm 0.5^\circ\text{F}$ ($0.5 \pm 0.3^\circ\text{C}$) per minute until the temperature reaches $40 \pm 5^\circ\text{F}$ ($22 \pm 2.8^\circ\text{C}$) above the nominal temperature rating of the sprinklers.

Partial fracture of a glass bulb or partial rupture of a fusible element, i.e., strutting, shall be deemed a failure.

4.10 Hang-Up of Operating Parts

4.10.1 Requirement

When tested as described below, not more than 1 percent of the samples shall exhibit a hang-up, or lodgment, of operating parts on the non-operating components (i.e. frame, compression screw, deflector, etc.) of the sprinkler.

For extended coverage type sprinklers, no sample may exhibit a hang-up or lodgment of operating parts on the non-operating components.

Samples shall operate fully and completely, and shall exhibit no binding of internal components. Upon operation, the discharge coefficient (K-factor) of all samples may be measured and shall comply with Section 4.15, Discharge Coefficient (K-Factor).

Any non-operation caused by binding of an operating element or improper fracturing of a glass bulb, shall be considered a hang-up. Momentary obstructions which clear in less than 60 seconds are not considered hang-ups. Pressures other than those shown in Table 4.10.2 may be tested at the sole discretion of the certification agency.

4.10.2 Tests/Verification

Samples shall be selected in accordance with Table 4.10.2 and shall be individually installed in their intended installation position, on a pipe manifold as described in Figure D-6. Each sample shall be subjected to an inlet water pressure in accordance with Table 4.10.2, operated using a suitable open flame heat source, and observed for complete and proper functioning. A total of 100 sprinklers shall be tested.

EXCEPTION: Dry sprinklers shall be tested at both the minimum and maximum lengths, and may require a total sample quantity of up to 200 sprinklers. The pipe manifold of Figure D-6 shall be modified by installing a plugged tee in place of the elbow and may be modified further to accommodate long samples of dry sprinklers.

Five samples shall be tested at each pressure with the pipe manifold configured for double-fed flow, and the remaining samples shall be tested with single-fed flow (see Figure D-6).

Upon activation of each sample, the discharge coefficient may be measured to verify proper and complete operation.

Table 4.10.2. Hang-Up Test Samples

<i>Pressure¹</i>		<i>Number of Samples</i>
<i>psi</i>	<i>(bar)</i>	
7	(0.5)	10
25	(1.7)	15
50	(3.4)	15
75	(5.2)	15
100	(6.9)	15
125	(8.6)	10
150	(10.3)	10
175	(12.1)	10

Note: ¹ A tolerance of ± 5 percent applies to all pressures specified in the table.

4.11 Strength of Deflector (Flow Endurance)

4.11.1 Requirement

The deflector as well as other non-operating components of the sprinkler, and their methods of attachment, shall be designed and manufactured such that sprinkler operation and subsequent water flow does not cause damage to these parts or cause their disengagement from the sprinkler. Following test completion, there shall be no evidence of deflector distortion, damage, or impending separation from the frame on any of the sprinklers tested. The deflector and other non-operating components shall not be loosened.

4.11.2 Tests/Verification

Three previously untested sample sprinklers shall be individually installed in the test apparatus detailed in Figure D-6 in their intended orientation. Water shall be introduced to the inlet of each sprinkler at a pressure of 225 ± 10 psi (15.5 ± 0.7 bar). Each sprinkler shall then be operated using a suitable heat source and water flow shall be adjusted to and maintained at 225 ± 10 psi (15.5 ± 0.7 bar) for a period of 15 minutes.

4.12 Vacuum

4.12.1 Requirement

Sprinklers shall be designed such that when the inlet of an assembled sprinkler is subjected to a vacuum, as might be experienced during draining of a sprinkler system, the sprinkler shall not be damaged or leak when tested as described in 4.12.2. Following this test, each sample shall not weep or leak at a pressure of 5 ± 0.5 psi (0.3 ± 0.03 bar) when tested in accordance with Section 4.4.2A (Hydrostatic Leakage). Additionally, each sample shall not weep or leak at a pressure at, or below, 500 psi (34.5 bar).

4.12.2 Tests/Verification

Three previously untested sprinklers shall be hydrostatically tested to confirm that there are no weep or leak points at, or below, 500 psi (34.5 bar). The sprinklers shall then be subjected to a vacuum of 26 in. Hg (0.88 bar) for a period of one minute.

Following this test, the samples shall be subjected to the post-tests detailed above.

4.13 High Ambient Temperature Exposure (90 Day Test)

4.13.1 Requirement

- A. Sprinklers shall be capable of withstanding an exposure to a high ambient temperature in accordance with Table 4.13.1.1 and Section 4.13.2 for a period of 90 days without evidence of weakness or failure. Following the exposure period, each sample shall not weep or leak at, or below, 500 psi (34.5 bar) when tested in accordance with Section 4.4.2A (Hydrostatic Leakage). Subsequently, half of the sprinklers shall be tested for conformance to the requirements for sensitivity as described in Sections 4.28 [Sensitivity - Response Time Index (RTI)], 4.29 [Sensitivity (Recessed, Flush, and Concealed Types)], and 4.30 [Sensitivity (Air Oven)], as applicable. The remaining samples shall be tested for operating temperature as described in Section 4.8 [Operating Temperature (Liquid Bath)]. Exceptions/additions are noted as described below.

Table 4.13.1.1. High Ambient Temperature Exposure Test Conditions

<i>Sprinkler Nominal Temperature Rating</i>		<i>Nominal¹ Test Temperatures</i>	
<i>°F</i>	<i>(°C)</i>	<i>°F</i>	<i>(°C)</i>
135 - 170	(57 - 77)	100	(38)
175 - 225	(79 - 107)	150	(66)

<i>Sprinkler Nominal Temperature Rating</i>		<i>Nominal¹ Test Temperatures</i>	
250 - 300	(121 - 149)	225	(107)
325 - 375	(163 - 191)	300	(149)
400 - 475	(204 - 246)	365	(185)
500 - 575	(260 - 302)	465	(241)
650	(343)	Evaluated on a case-by-case basis	

Note: ¹Tolerance on Nominal Test Temperature at stabilized condition: ± 3°F (1.7°C)

- B. High ambient temperature can affect platings and coatings such as decorative (painting) or corrosion resistant (wax, asphalt, etc...) which may ultimately impact the performance of sprinklers. Samples having such finishes may be subjected to this test at the discretion of the certification agency. Following exposure, there shall be no evidence of shrinking, hardening, cracking, or flaking of the coating or plating.
- C. For sprinkler coatings which contain volatiles, such as wax coatings, the softening point determined in accordance with ASTM E28 shall be at least 20°F (11°C) under the nominal temperature rating of the sprinklers and not less than 20°F (11°C) above the maximum allowed installation temperature. Sprinklers with coatings that do not meet this requirement shall be evaluated on a case-by-case basis. The permissible softening point temperatures are summarized in Table 4.13.1.2.

Table 4.13.1.2. Permitted Softening Points of Volatile Sprinkler Coatings

<i>Sprinkler Nominal Temperature Rating</i>		<i>Minimum Softening Point Temperature</i>		<i>Maximum Softening Point Temperature</i>	
<i>°F</i>	<i>(°C)</i>	<i>°F</i>	<i>(°C)</i>	<i>°F</i>	<i>(°C)</i>
0 - 139	(0 - 59)	Evaluated on a case-by-case basis			
140 - 170	(60 - 77)	120	(49)	120 - 150	(49 - 65)
171 - 189	(78 - 87)	Not Permitted			
190 - 225	(88 - 107)	170	(77)	170 - 205	(77 - 96)
226 - 264	(108 - 129)	Not Permitted			
265 - 300	(130 - 149)	245	(118)	245 - 280	(118 - 138)
301 - 339	(150 - 170)	Not Permitted			
340 - 375	(171 - 191)	320	(160)	320 - 355	(160 - 179)
376+	(192+)	Evaluated on a case-by-case basis			

- D. For dry-type sprinklers, samples may be tested to verify clearing of the waterway when operated using a suitable heat source, in the prescribed orientation with the appropriate associated minimum inlet water pressure as stated in Table 4.25.1 (Minimum Operating Pressure).
- E. Concealed-type sprinklers incorporating a solder alloy or other temperature sensitive material to attach the cover plate shall not experience separation of the cover plate during the exposure. Following the test, sprinkler covers shall be tested for operating temperature as stated in Section 4.8 [Operating Temperature (Liquid Bath)].

4.13.2 Tests/Verification

- A. Ten previously untested sprinklers shall be hydrostatically tested to confirm that there are no weep or leak points at, or below, 500 psi (34.5 bar). The samples shall then be placed in an automatically controlled, air circulating constant-temperature oven and subjected to a high ambient temperature selected in accordance with Table 4.13.1.1 for a period of 90 ± 1 days.

- B. For coatings which contain volatiles, such as wax coatings, a sample of the coating shall be placed in an open container and subjected to the maximum allowed installation temperature of the sprinkler as stated in Table 4.13.1.2 for a period of 90 ± 1 days. Prior to and following the exposure period, the softening point of these coating samples shall be determined using ASTM E28, *Test Method for Softening Point by Ring and Ball Apparatus*, or its equivalent as determined by the certification agency.

Following these tests, the samples shall be subjected to the post-tests detailed above. Manufacturers may submit additional samples for evaluation prior to completion of the required test period. Results from such samples may be used to terminate the test early.

4.14 Thermal Shock (Glass Bulb Sprinklers Only)

4.14.1 Requirement

Sprinklers having frangible glass bulbs shall operate within their nominal operating temperature range after being exposed to a series of rapid temperature changes (i.e. thermal shocks). Operation of a sprinkler during the cycling portion of this test shall be deemed unacceptable. Following the sequence detailed in Section 4.14.2, each sample shall meet the operating temperature requirements specified in Section 4.8 [Operating Temperature (Liquid Bath)].

4.14.2 Tests/Verification

Five previously untested samples shall be conditioned for 5 ± 1 minutes in a liquid bath maintained at a temperature of seven percent below their nominal rating. The bath liquid shall be selected in accordance with Table 4.8.2.

The sprinklers shall then be removed and immediately submerged for a period of 15 to 30 seconds into a second liquid bath maintained at $50 \pm 5^\circ\text{F}$ ($10 \pm 2.8^\circ\text{C}$). This sequence of heating and plunging into the cold liquid bath shall be repeated three times on each sample.

Following this test, the samples shall be subjected to the post-tests detailed above.

4.15 Discharge Coefficient (K-Factor)

4.15.1 Requirement

The mean value of the discharge coefficient (K-factor) shall be consistent with Table 4.15.1 when sprinklers are tested as detailed in Section 4.15.2. For each sample and pressure direction, not more than one individual value shall fall outside of the stated range.

Table 4.15.1. K-Factor Ranges

<i>Nominal Discharge Coefficient</i> (gal/min/(psi) ^{1/2}) (L/min/(bar) ^{1/2})		<i>Nominal Discharge Coefficient Range</i> (gal/min/(psi) ^{1/2}) (L/min/(bar) ^{1/2})	
2.8	40	2.6 - 2.9	38 - 42
5.6	80	5.3 - 5.8	76 - 84
8.0	115	7.4 - 8.2	107 - 118
11.2	160	10.7 - 11.7	154 - 168
14.0	200	13.5 - 14.5	195-209
16.8	240	16.0 - 17.6	231-254
19.6	280	18.6 - 20.6	268 - 297
25.2	360	23.9 - 26.5	344-382

4.15.2 Tests/Verification

Four samples shall be individually tested using the test apparatus for determining K-factor shown in Figure D-7 at increasing and decreasing pressures over the complete operating range, 25 to 175 psi (1.7 to 12.1 bar) in 10 psi (0.7 bar) increments. With the deflector and a portion of the frame

removed, if necessary, to facilitate testing, each sample shall be inserted into the test fixture and torqued to a rotation one-half turn (180 degrees) beyond "hand tight" using an appropriate wrench.

EXCEPTION: In order to evaluate potential distortion of thin-walled waterways, sprinklers with a nominal K-factor of 11.2 gal/min/(psi)^{1/2} incorporating 1/2 in. NPT threaded connections or sprinklers with a nominal K-factor greater than 14.0 gal/min/(psi)^{1/2} utilizing 3/4 in. NPT threaded connections may be tested with installation torques of both "hand tight" and "hand tight" plus one full turn.

The K-factor shall be determined using the expression:

$$K = \frac{Q}{P^{1/2}}$$

where Q = flow rate [gal/min (L/min)] and P = pressure [psi (bar)].

For dry (fixed length) sprinklers, tests shall be conducted on a minimum of two of the longest and two of the shortest lengths, and may be conducted on one sample of an intermediate length.

For dry (adjustable type) sprinklers, tests shall be conducted on a minimum of two samples while adjusted to the longest and the shortest length, and may be conducted at one intermediate position.

4.16 Moist Air

4.16.1 Requirement

Sprinklers shall withstand an exposure to high temperature and humidity for a continuous period of 90 days. Following the exposure, samples shall not weep or leak at, or below, 175 psi (12.1 bar) when tested in accordance with Section 4.4.2A (Hydrostatic Leakage). Subsequently, the samples shall exhibit positive operation and release of all operating parts at the minimum operating pressure stated in Table 4.25.1 when tested in accordance with Section 4.25.2 (Minimum Operating Pressure).

4.16.2 Tests/Verification

Five previously untested sprinklers shall be hydrostatically tested to confirm that there are no weep or leak points at, or below, 500 psi (34.5 bar). They shall then be exposed to an atmosphere having a relative humidity of 98 percent \pm 2 percent and a temperature of 203 \pm 2°F (95 \pm 1.1°C) for a period of 90 \pm 1 days. If the exposure temperature nears or exceeds the nominal temperature rating of the sprinkler, the heat responsive element shall be specially fabricated to prevent operation during this test. The sprinklers shall be installed on a pipe manifold which contains water in approximately 50 percent of its volume. The entire manifold, along with the sprinklers, shall be placed in the high temperature and humidity enclosure for the duration of the test.

Following this test, the samples shall be subjected to the post-tests detailed above.

4.17 Corrosion - Salt Spray

4.17.1 Requirement

In order to evaluate the resistance to corrosion of the assembly, such as might be experienced by dissimilar materials in contact over long periods of time, sprinklers, other than flush and concealed types, shall withstand a timed exposure to a salt spray atmosphere.

NOTE: At the manufacturer's request, the the certification agency will test flush or concealed type sprinklers and, if successful in this and other exposure tests, may certify these sprinklers for use in atmospheres subject to corrosion.

When tested as detailed in Section 4.17.2, visual evidence of severe deterioration or impending failure of any component shall constitute failure. Following exposure, all of the samples shall be subjected to a hydrostatic pressure of 175 psi (12.1 bar) for one minute without leakage. Subsequently, the sprinklers shall be tested for conformance to the requirements for sensitivity as

described in Sections 4.28 [Sensitivity - Response Time Index (RTI)], 4.29 [Sensitivity (Recessed, Flush, and Concealed Types)], and 4.30 [Sensitivity (Air Oven)], as applicable. At the discretion of the certification agency, some or all of the samples may be tested for operating temperature as described in Section 4.8 [Operating Temperature (Liquid Bath)]. Should the deflector or other non-operating components, or their attachment method, exhibit questionable corrosive attack, at least one sample shall be subjected to water flow at a pressure of 175 psi (12.1 bar) for a period of one minute. Upon completion of this test, the deflector shall not show evidence of fracture, distortion or impending separation from the frame.

4.17.2 Tests/Verification

Eight previously untested samples shall be hydrostatically tested to confirm that there are no weep or leak points at, or below, 500 psi (34.5 bar).

Each sprinkler inlet shall be filled with deionized water and sealed with a non-reactive material (e.g., plastic cap) so as to prevent the introduction of salt fog into the waterway of the sprinkler. When feasible, each sprinkler shall be supported in its intended installation position.

EXCEPTION: Cover plates, common to the design of concealed sprinklers, shall be tested separately and shall be oriented such that salt fog residue and condensate cannot pool on the plate.

The samples shall be exposed to salt spray (fog) as specified by ASTM B117, *Standard for Salt Spray (Fog) Testing*. The salt solution shall consist of 20 percent by weight of common salt (sodium chloride) dissolved in deionized water.

The samples shall be exposed for a period of 10 days.

When sprinklers are intended to be classified as corrosion resistant, the samples shall be exposed for a period of 30 days.

Following exposure to the salt fog, the samples shall be removed from the test chamber and permitted to air dry for a two- to four-day drying period. Following this drying period, the samples shall be subjected to the post-exposure tests detailed above.

4.18 Corrosion - Stress Cracking

4.18.1 Requirement

Sprinklers shall be resistant to stress corrosion cracking, as determined through the process described below. Following exposure, the samples shall not show evidence of cracking, delamination, or degradation.

After exposure, the sprinklers shall not weep or leak at, or below, 175 psi (12.1 bar) when hydrostatically tested for one minute. Subsequently, half of the samples shall exhibit positive operation and release of all operating parts at the minimum operating pressure when tested in accordance with Section 4.25.2 (Minimum Operating Pressure). The remaining samples shall be subjected to a water flow at a pressure of 175 psi (12.1 bar) for a period of one minute. Upon completion of this test, the deflector shall not show evidence of fracture, distortion or impending separation from the frame.

4.18.2 Tests/Verification

A. Copper Based Parts (Ammonia Test)

In order to determine the susceptibility of copper based sprinkler parts to stress corrosion cracking, four previously untested sprinklers shall be hydrostatically tested to confirm that there are no weep or leak points at, or below, 500 psi (34.5 bar). The samples shall then be subjected to a moist ammonia environment for a period of 10 days.

The inlet end of each sample shall be filled with deionized water and sealed with a non-reactive material (e.g., plastic cap) so as to prevent the introduction of the ammonia atmosphere into the waterway of the sprinkler. The samples to be tested shall be free from any non-permanent

protective coating and, if necessary, shall be degreased. If a permanent coating is an inherent part of the design, such coating shall be subjected to tests as deemed necessary by the certification agency to evaluate its protective integrity. When feasible, the samples shall be tested in their intended orientation.

There shall be provisions in the test chamber to prevent droplets of condensation from falling from the top of the enclosure directly onto the sprinklers. Such shield or other means shall be constructed of glass or other non-reactive materials.

The samples shall be exposed to the moist ammonia-air mixture maintained in a glass chamber with a volume of $0.73 \pm 0.43 \text{ ft}^3$ ($0.02 \pm 0.01 \text{ m}^3$).

Aqueous ammonia having a density of $58.7 \pm 0.6 \text{ lb/ft}^3$ ($0.94 \pm 0.01 \text{ g/cm}^3$) shall be maintained in the bottom of the chamber, approximately 1.5 in. (40 mm) below the bottom of the samples. A volume of aqueous ammonia equal to $0.075 \pm 0.006 \text{ gal/ft}^3$ ($10 \pm 0.86 \text{ L/m}^3$) of the test chamber volume shall result in approximately the following atmospheric concentrations: 35 percent ammonia, 5 percent water vapor, and 60 percent air. Prior to beginning the exposure, the test chamber shall be conditioned to a temperature of $93 \pm 4^\circ\text{F}$ ($34 \pm 2^\circ\text{C}$) for a period of not less than one hour, and shall be maintained as such throughout the exposure period. The moist ammonia-air mixture shall be maintained at essentially atmospheric pressure. Provision shall be made for venting the chamber, such as by the use of a capillary tube, to avoid buildup of pressure.

Upon removal, sprinklers shall be rinsed in potable water and air dried. Following a two- to four-day drying period, visual examination of the samples shall be made. The samples shall then be subjected to the post-exposure tests detailed above.

B. Austenitic, Ferritic, and Duplex Stainless Steel Parts (Boiling Magnesium Chloride Test)

In order to determine the susceptibility of stainless steel sprinkler parts to stress corrosion cracking, at least two previously untested sprinklers shall be degreased and then exposed to a boiling magnesium chloride solution for a period of 500 ± 12 hours as described below, and in accordance with ASTM G36, *Standard Practice for Evaluating Stress-Corrosion-Cracking Resistance of Metals and Alloys in a Boiling Magnesium Chloride Solution*. Special fixtures or elevated temperature operating elements may be employed to simulate assembly loading on parts, where appropriate.

Samples are to be placed in a flask fitted with a wet condenser. The flask shall be filled approximately one-half full with a nominal 44 percent by weight magnesium chloride solution, placed on a thermostatically-controlled electrically-heated mantle, and maintained at a boiling temperature of $302^\circ\text{F} \pm 4^\circ\text{F}$ ($150^\circ\text{C} \pm 2^\circ\text{C}$).

Following exposure, the samples shall be removed and rinsed in potable water. Following a two- to four-day drying period, visual examination of the samples shall be made. The samples shall then be subjected to the post-exposure tests detailed above.

C. Parts Manufactured from Other Materials

Parts manufactured from other materials shall withstand comparable tests based upon the type of material employed at the discretion of the certification agency.

4.19 Corrosion - Carbon Dioxide-Sulfur Dioxide

4.19.1 Requirement

Sprinklers, other than flush and concealed types, shall be resistant to corrosion resulting from exposures to a moist carbon dioxide-sulfur dioxide-air mixture.

NOTE: At the manufacturer's request, the certification agency will test flush or concealed type sprinklers and, if successful in this and other exposure tests, may Approve these sprinklers for use in atmospheres subject to corrosion.

Following the exposure period, the samples shall be examined for deterioration or impending failure of any component. Such condition is unacceptable and constitutes failure. Following the

visual examination, the samples shall not weep or leak at, or below, 175 psi (12.1 bar) when hydrostatically tested for one minute. Subsequently, half of the samples shall be tested for compliance with Section 4.8 [Operating Temperature (Liquid Bath)], and half of the samples shall be tested for conformance to the requirements for sensitivity as described in Sections 4.28 [Sensitivity - Response Time Index (RTI)], 4.29 [Sensitivity (Recessed, Flush, and Concealed Types)], and 4.30 [Sensitivity (Air Oven)], as applicable. Should the deflector or other non-operating components, or their means of attachment exhibit questionable corrosive attack, at least one sample shall be subjected to water flow at a pressure of 175 psi (12.1 bar) for a period of one minute. Upon completion of this test, the deflector shall not show evidence of fracture, distortion or impending separation from the frame.

4.19.2 Tests/Verification

Four previously untested sprinklers shall be hydrostatically tested to confirm that there are no weep or leak points at, or below, 500 psi (34.5 bar). The samples shall then be exposed to a moist carbon dioxide-sulfur dioxide-air mixture for a period of 10 days.

When sprinklers are intended to be classified as corrosion resistant, the samples shall be exposed for a period of 30 days.

The inlet end of each sample shall be filled with deionized water and sealed with a non-reactive material (e.g., plastic cap) so as to prevent the introduction of the gas mixture into the waterway of the sprinkler. When feasible, each sprinkler shall be tested in its intended installation position.

EXCEPTION: Cover plates, common to the design of concealed sprinklers, shall be tested separately and shall be oriented such that residue and condensate cannot pool on the plate.

There shall be provisions in the test chamber to prevent droplets of condensation from falling from the top of the enclosure directly onto the sprinklers. Such shield or other means shall be constructed of glass or other non-reactive materials.

The samples shall be tested in a chamber having provisions for gas inlet and outlet. Sulfur dioxide and carbon dioxide are to be supplied to the test chamber from commercial cylinders. An amount of sulfur dioxide equivalent to one percent of the volume of the test chamber, and an equal volume of carbon dioxide shall be introduced into the chamber each day after the chamber has been purged. Approximately 0.53 gallons (2.0 liters) of deionized water shall be maintained in the bottom of the chamber.

Following the exposure, the samples shall be removed from the test chamber and permitted to air dry for a two- to four-day drying period. Following this drying period, the samples shall be subjected to the post-exposure tests detailed above.

4.20 Corrosion - Hydrogen Sulfide

4.20.1 Requirement

Sprinklers, other than flush and concealed types, shall be resistant to corrosion resulting from exposures to a moist hydrogen sulfide-air mixture.

NOTE: At the manufacturer's request, the certification agency will test flush or concealed type sprinklers and, if successful in this and other exposure tests, may Approve these sprinklers for use in atmospheres subject to corrosion.

Following the exposure period, the samples shall be examined for deterioration or impending failure of any component. Such condition is unacceptable and constitutes failure. Following the visual examination, the samples shall not weep or leak at, or below, 175 psi (12.1 bar) when hydrostatically tested for one minute. Subsequently, half of the samples shall be tested for compliance with Section 4.8 [Operating Temperature (Liquid Bath)], and half of the samples shall be tested for conformance to the requirements for sensitivity as described in Sections 4.28 [Sensitivity - Response Time Index (RTI)], 4.29 [Sensitivity (Recessed, Flush, and Concealed Types)], and 4.30 [Sensitivity (Air Oven)], as applicable. Should the deflector or other non-operating components, or their means of attachment exhibit questionable corrosive attack, at least

one sample shall be subjected to water flow at a pressure of 175 psi (12.1 bar) for a period of one minute. Upon completion of this test, the deflector shall not show evidence of fracture, distortion or impending separation from the frame.

4.20.2 Tests/Verification

Four previously untested sprinklers shall be hydrostatically tested to confirm that there are no weep or leak points at, or below, 500 psi (34.5 bar). They shall then be exposed to a moist hydrogen sulfide-air mixture for a period of 10 days.

When sprinklers are intended to be classified as corrosion resistant, the samples shall be exposed for a period of 30 days.

The inlet end of each sample shall be filled with deionized water and sealed with a non-reactive material (e.g., plastic cap) so as to prevent the introduction of the gas mixture into the waterway of the sprinkler. When feasible, each sprinkler shall be tested in its intended installation position.

EXCEPTION: Cover plates, common to the design of concealed sprinklers, shall be tested separately and shall be oriented such that residue and condensate cannot pool on the plate.

There shall be provisions in the test chamber to prevent droplets of condensation from falling from the top of the enclosure directly onto the sprinklers. Such shield or other means shall be constructed of glass or other non-reactive materials.

The samples shall be tested in a chamber having provisions for gas inlet and outlet. Hydrogen sulfide is to be supplied to the test chamber from a commercial cylinder. An amount of hydrogen sulfide equivalent to one percent of the volume of the test chamber shall be introduced into the chamber each day after the chamber has been purged. Approximately 0.53 gallons (2.0 liters) of deionized water shall be maintained in the bottom of the chamber.

Following the exposure, the samples shall be removed from the test chamber and permitted to air dry for a two- to four-day drying period. Following this drying period, the samples shall be subjected to the post-exposure tests detailed above.

4.21 Vibration

4.21.1 Requirement

Sprinklers shall be capable of withstanding the effects of vibration without deterioration of their performance characteristics. Following the vibration test detailed in Section 4.21.2, the sprinklers shall not weep or leak at, or below, 500 psi (34.5 bar) when tested in accordance with Section 4.4.2A (Hydrostatic Leakage). Subsequently, the sprinklers shall be tested for conformance to the requirements for sensitivity as described in Sections 4.28 [Sensitivity - Response Time Index (RTI)], 4.29 [Sensitivity (Recessed, Flush, and Concealed Types)], and 4.30 [Sensitivity (Air Oven)], as applicable.

4.21.2 Tests/Verification

Four previously untested sprinklers shall be hydrostatically tested to confirm that there are no weep or leak points at, or below, 500 psi (34.5 bar). The samples shall then be subjected to the vibration conditions stated in Table 4.21.2.

Table 4.21.2. Vibration Conditions

<i>Total Displacement in. (mm)</i>	<i>Frequency Hz</i>	<i>Time Hours</i>
0.020 (0.51)	28	5
0.040 (1.02)	28	5
0.150 (3.81)	28	5
0.040 (1.02)	18 to 37 variable	5
0.070 (1.78)	18 to 37 variable	5

For the variable frequency conditions, the frequency shall be varied with a cycle period of 25 ± 5 seconds.

The sprinklers shall be attached to a rigid mounting plate and the plate bolted to the table of a vibration machine so that the sprinklers are vibrated vertically. This test shall be conducted with the sprinklers unpressurized. The sprinklers may be pressurized for this test at the sole discretion of the certification agency.

The sprinklers shall be subjected to the above vibration conditions and continuously monitored for 15 minutes at each condition (75 minutes total). If one or more resonant point(s) is detected, the sprinklers shall be vibrated for the remainder of the test at such frequency(ies) for a period of time proportionate to the number of resonant frequencies. Otherwise the sprinklers shall be subjected to each vibration condition for a period of 5 hours (25 hours total).

Following this test, the samples shall be subjected to the post-tests detailed above.

4.22 Rough Use and Abuse

4.22.1 Requirement

Sprinklers shall have adequate strength to withstand impacts associated with handling, shipment, and installation without deterioration of performance or reliability. Following the tests detailed below, a visual examination of each sprinkler shall reveal no permanent distortion, cracks, breaks, or other evidence of impending failure. Also, each sprinkler shall not weep or leak at, or below, 500 psi (34.5 bar) when tested in accordance with Section 4.4.2A (Hydrostatic Leakage). Subsequently, the samples shall be tested for conformance to the requirements for sensitivity as described in Sections 4.28 [Sensitivity - Response Time Index (RTI)], 4.29 [Sensitivity (Recessed, Flush, and Concealed Types)], and 4.30 [Sensitivity (Air Oven)], as applicable. Complete operation of a sprinkler during the tumble test described in Section 4.22.2B is permitted.

In-rack sprinklers shall only be tested to Sections 4.22.2A and 4.22.2C and shall be visually examined for evidence of damage. Guards shall only be tested to Section 4.22.2D and shall be visually examined for evidence of damage.

This test is not required for dry sprinklers if they are packaged in such a fashion as to preclude damage during shipping. Additional testing shall be at the sole discretion of the certification agency.

4.22.2 Tests/Verification

- A. Drop Test - Five previously untested sprinklers shall be hydrostatically tested to confirm that there are no weep or leak points at, or below, 500 psi (34.5 bar). Each sprinkler shall then be tested by dropping a weight equal to that of the sprinkler, ± 0.011 lb (± 5 g), onto the deflector end of the sprinkler along the axial centerline of the waterway (see Figure D-8). The weight shall be dropped from a height of $3.2 \text{ ft} \pm 2 \text{ in.}$ ($1.0 \text{ m} \pm 50 \text{ mm}$) above the deflector. The weight shall be prevented from impacting the test sample more than once.
- B. Tumble Test - Five previously untested sprinklers shall be hydrostatically tested to confirm that there are no weep or leak points at, or below, 500 psi (34.5 bar). Each sprinkler shall then be individually subjected to a tumbling test for three minutes. Sprinklers provided with shipping caps, which are intended for removal only after completion of the sprinkler installation, shall be tested with the caps in place. Each sample shall be placed in a vinyl lined right hexagonal prism shaped drum designed to provide a tumbling action. The drum shall have a length along the axis of rotation of 10 in. (255 mm). The internal distance between two opposite and parallel sides of the drum shall be 12 in. (305 mm). For each test, the drum shall contain one sprinkler and five wood blocks. The blocks shall be 1.5 ± 0.12 in. (40 ± 3 mm) cubes made of hardwood (i.e. oak, maple, etc.). The drum shall be rotated at one revolution per second about its longitudinal axis.
- C. For in-rack sprinklers, five previously untested samples shall not sustain damage when the assembled sprinklers are individually dropped from a height of 30 ± 1 in. (760 ± 25 mm) onto a concrete surface such that the shield impacts the floor at an angle. The shield shall not shear off or

bend as a result of this impact. If rotation of the shield is possible, such rotation shall not alter the assembly load on the sprinkler.

- D. For sprinklers with guards, five previously untested samples shall not sustain damage when the sprinkler/guard assemblies are individually dropped 3 times from a height of 10 ft (3.04 m) onto a concrete surface. Sprinklers shall not show evidence of damage after the drop sequence. The guards shall not make contact with the sprinkler deflector or become separated from the sprinkler as a result of the drop sequence.

Following these tests, the samples shall be subjected to the post-tests detailed above.

4.23 High Temperature Exposure

4.23.1 Requirement

Sprinklers, less operating mechanisms, shall not show significant deformation, blistering, or fracture following exposure to an elevated temperature as detailed below. The certification agency may conduct Discharge Coefficient (K-Factor), (Section 4.15) and/or Distribution (Section 4.31, 4.32 or 4.33) tests on exposed samples to validate compliance with these requirements.

4.23.2 Tests/Verification

One previously untested, but open, sprinkler, supported on its threaded inlet, shall be heated in an oven or furnace having a temperature of $1470 \pm 20^\circ\text{F}$ ($800 \pm 11^\circ\text{C}$) for a period of 15 minutes. Following this exposure, the sprinkler shall be removed with tongs, preferably by holding the threaded inlet portion, and promptly submerged in a water bath with a temperature of $60 \pm 10^\circ\text{F}$ ($15 \pm 6^\circ\text{C}$).

4.24 Freezing

4.24.1 Requirement

Following exposure to freezing temperatures, sprinklers shall either (a) operate, (b) leak subsequent to thawing when hydrostatically pressurized from 5 to 175 psi (0.35 to 12.1bar), or (c) sustain no damage. For (c), sprinklers shall not weep or leak at, or below, 500 psi (34.5 bar) and subsequently, the sprinklers shall be tested for conformance to the requirements for sensitivity as described in Sections 4.28 [Sensitivity - Response Time Index (RTI)], 4.29 [Sensitivity (Recessed, Flush, and Concealed Types)], and 4.30 [Sensitivity (Air Oven)], as applicable.

4.24.2 Tests/Verification

Two previously untested sprinklers shall be hydrostatically tested to confirm that there are no weep or leak points at, or below, 500 psi (34.5 bar). Each sprinkler shall be attached to one end of a 10 in. (254 mm) minimum length of 1 in. nominal diameter Schedule 40 or 80 steel pipe using an appropriate fitting. Each assembly shall then be filled to capacity with water and sealed. The samples shall then be exposed to a temperature of $-20^\circ\text{F} \pm 10^\circ\text{F}$ ($-30^\circ\text{C} \pm 5^\circ\text{C}$) for a period of 24 hours, or until operation occurs.

Following this test, the samples shall be subjected to the post-tests detailed above.

4.25 Minimum Operating Pressure

4.25.1 Requirement

Sprinklers shall be designed to produce positive operation and release of all operating parts at the minimum operating pressure stated in Table 4.25.1. Following operation of the heat responsive element, all parts which are intended to prohibit the discharge or leakage of water shall clear the exit of the waterway within 5 seconds.

For sprinklers designed such that moveable parts are not intended to be released or expelled, proper actuation of all components to permit full water discharge is required.

Table 4.25.1. Minimum Operating Pressure

Type of Sprinkler	Operating Pressure	
	psi	(bar)
Dry upright	10	(0.7)
K-factor 2.8 and 5.6	3	(0.2)
All others, including all other dry types	5	(0.3)

4.25.2 Tests/Verification

Ten previously untested sprinklers shall be individually installed on a pipe manifold in their intended orientation, if feasible, and subjected to an inlet water pressure at, or below, that shown in Table 4.25.1. Each sample shall be operated using a suitable heat source. If a sample does not operate fully as described above, the pressure shall be slowly increased to determine the actual minimum operating pressure.

4.26 Process Residue

4.26.1 Requirement

In order to evaluate the resistance of the assembly to years of service in dusty or corrosive environments, sprinklers, other than flush and concealed types, shall withstand a timed exposure to a salt spray atmosphere.

4.26.2 Tests/Verification

Verification of Section 4.26.1 shall be made in conjunction with Section 4.17 (Corrosion - Salt Spray). Additional process residue tests may be conducted at the discretion of the certification agency.

4.27 Conductivity (C-Factor)

4.27.1 Requirement

The conductivity (C-factor) shall not exceed $1.81 \text{ (ft/s)}^{1/2}$ [$1.0 \text{ (m/s)}^{1/2}$] for quick response and extended coverage type sprinklers. Standard response sprinklers shall have a C-factor not exceeding $3.62 \text{ (ft/s)}^{1/2}$ [$2.0 \text{ (m/s)}^{1/2}$].

Coated, dry, flush, recessed and concealed sprinklers are not subject to these requirements.

4.27.2 Tests/Verification

The C-factor shall be determined using the prolonged plunge test method. The prolonged plunge test is an iterative process to determine the C-factor and may require up to twenty sprinkler samples. A new sprinkler sample shall be used for each test even if the sample does not operate during the test.

Determination of the C-factor shall be performed with sprinklers of each nominal temperature rating in the "best case" orientation as determined in the Sensitivity Test (Section 4.28).

Prior to testing, each sprinkler shall have one to three wraps of PTFE sealant tape applied to the threads. Sprinklers shall be allowed to reach ambient temperature for a period of not less than 30 minutes.

A minimum of 0.1 oz. (3 ml) of water, conditioned to ambient temperature, shall be introduced into the sprinkler inlet and mounting fixture prior to testing.

All sprinklers are to be tested with the inlet end of each sample connected to a source of pressure at $5 +0.5/-0 \text{ psi}$ [$0.3(+0.04/-0) \text{ bar}$]. All tests shall be conducted with the geometric center of the heat responsive element located at least 1.5 in. (38 mm) from the interior horizontal surfaces of the test section, and with the centerline of the waterway perpendicular to the airflow in the test chamber.

A timer accurate to ± 0.01 seconds with suitable measuring devices to sense the time between when the sprinkler is plunged into the tunnel and when it operates shall be utilized to obtain the response time.

The mount temperature shall be maintained at 68 ± 2°F (20 ± 1°C) for the duration of each test. The mount temperature shall be recorded at the beginning of the test and at the time of sprinkler operation. If a sample does not operate, the mount temperature shall be recorded after 15 minutes has elapsed. Testing shall start with a tunnel gas temperature from the range detailed in Table 4.27.2.

To determine the C-factor, each sprinkler shall be immersed in the test stream at a selected gas velocity and air temperature for a maximum of 15 minutes. The average gas velocity in the tunnel test section at the sprinkler location shall be maintained within ± 0.2 ft/s (0.07 m/s) of the selected velocity. Velocities are to be chosen such that actuation is bracketed between two successive test velocities. That is, two velocities shall be established such that, at the lower velocity (u_L), actuation does not occur in the 15 minute test interval. At the next higher velocity (u_H), actuation shall occur within the 15 minute time limit. To establish u_L and u_H , the velocity shall be raised by 10 percent increments within the range detailed in Table 4.27.2. If the sprinkler does not operate at the highest velocity in the range, a higher temperature shall be used and the same procedure repeated.

Table 4.27.2. Range of Test Conditions for C-factor

Sprinkler Nominal Operating Temperature ¹		Tunnel Gas Temperature °F (°C)	Tunnel Gas Velocity ft/s (m/s)	Maximum Variation of Gas Temperature During Test From Selected Temperatures	
°F	(°C)			°F	(°C)
135 - 170	(57 - 77)	190 - 765 (88 - 407)	0.7 - 10 (0.2 - 3.05)	± 11	(± 6)
170 - 225	(79 - 107)			± 16	(± 9)
250 - 300	(121 - 149)			± 45	(± 25)
325 - 375	(163 - 191)			± 45	(± 25)

Note: ¹For temperature ratings between those shown, a linear interpolation shall be used to determine the maximum variation from selected temperature.

Test velocity selection shall insure that:

$$(u_H/u_L)^{1/2} \leq 1.1$$

The C-factor of the sprinkler is determined by computing the average of the C-factors calculated at the two velocities (u_H and u_L) using the following equations:

$$C_H = (\Delta T_g / \Delta T_b - 1) u_H^{1/2} \qquad C_L = (\Delta T_g / \Delta T_b - 1) u_L^{1/2} \qquad C = \frac{C_L + C_H}{2}$$

Where:

C_H is the C-factor at velocity u_H

C_L is the C-factor at velocity u_L

C is the average C-factor of the sprinkler

ΔT_g is the actual gas (air) temperature minus the mount temperature

ΔT_b is the mean liquid bath operating temperature minus the mount temperature

u_H is the actual gas velocity in the test section at which the sprinklers operated

u_L is the actual gas velocity in the test section at which the sprinklers failed to operate within 15 minutes

The C-factor is determined by repeating the bracketing procedure. The C-factor values from at least two non-operations shall be averaged. The C-factor values from at least two operations shall be averaged. The final C-factor value is the calculated numerical average of these two values.

4.28 Sensitivity - Response Time Index (RTI)

4.28.1 Requirement

The following definitions apply to this section:

Orientation, Best Case – The orientation of a sprinkler which results in the fastest operating time, or the lowest Response Time Index (RTI). Typically, this orientation is one in which the sprinkler waterway axis and the plane of the frame arms are both perpendicular to the air flow and, in the case of non-symmetric elements, the heat responsive element is upstream of the frame arms.

Orientation, Worst Case – For use in this standard, the worst case orientation is a given angular offset from the orientation which results in the slowest operating time, or the highest Response Time Index (RTI). For standard response sprinklers, this angular offset is 15 degrees. The angular offset for quick response sprinklers is 25 degrees.

- A. All new standard response sprinklers, with the exception of coated, flush, recessed, and concealed types, shall meet the following requirements:
 1. The Response Time Index (RTI) shall fall within the limits detailed in Figure D-2 when the sprinkler is tested in the best case orientation as described in Section 4.28.2.
 2. The RTI shall be less than or equal to $1090 \text{ (ft}\cdot\text{s)}^{1/2}$ [$600 \text{ (m}\cdot\text{s)}^{1/2}$], or 250 percent of the measured RTI in the best case orientation, whichever is less, when the sprinkler is tested in the worst case orientation as described in Section 4.28.2.
- B. All new quick response sprinklers, with the exception of coated, flush, recessed, and concealed types, shall have an RTI not exceeding $90 \text{ (ft}\cdot\text{s)}^{1/2}$ [$50 \text{ (m}\cdot\text{s)}^{1/2}$] when tested in the best case orientation.
- C. Unless otherwise permitted due to results of performance based testing, such as full scale fire tests, extended coverage non-storage (light and ordinary hazard) type sprinklers shall meet the requirements for quick response sprinklers.
- D. Recessed, flush and concealed sprinklers shall comply with the requirements of the Sensitivity Test for recessed, flush and concealed sprinklers (Section 4.29).
- E. In the case of sprinklers for which testing in accordance with Section 4.28.2 is not practical (such as wax coated), the sensitivity requirement shall be that the time for operation in a controlled rate-of-temperature-rise air oven not exceed the limits shown in Table 4.30.1.2 or Table 4.30.1.3, as appropriate, when tested in accordance with the Air Oven Sensitivity Test (Section 4.30).
- F. As an exception to the RTI limits in this section, one of the ten RTI values may deviate from the specified limits by not more than 10 percent.

4.28.2 Tests/Verification

Compliance with the requirements for RTI shall be determined by operating sprinkler samples in the plunge tunnel, as described below. The plunge tunnel is further described in documents 1 through 4 as referenced in Section **Error! Reference source not found.** All tests shall be conducted with the geometric center of the heat responsive element located at least 1.5 in. (38 mm) from the interior horizontal surfaces of the test section, and with the waterway centerline perpendicular to the air flow through the test chamber.

- A. Ten samples shall be tested in the best case orientation, as described in Section 4.28.1. If, in the judgment of the certification agency, compliance with the requirements for worst-case RTI (See Section 4.28.1A.1) is in question, a sufficient number of tests may be conducted in various sprinkler orientations relative to air flow, such that the worse-case orientation is determined. Subsequently, five samples shall be tested in the worst case orientation, and five samples shall be tested in the best case orientation.
- B. The plunge tests are conducted using the sprinkler mount detailed in Figure D-9. Each sprinkler shall have one to three wrap(s) of PTFE sealant tape applied to the sprinkler threads and shall be

threaded into the mount at the sprinkler mounting connection. An air supply is then attached at the air hose connection and shall be pressurized to 5 (+0.5/-0) psi [0.3 (+0.04/-0) bar].

- C. A tunnel with gas velocity and temperature conditions at the test section established in accordance with Table 4.28.2 shall be utilized to conduct the sensitivity test. To minimize radiation exchange between the sensing element and the boundaries confining the flow, the test section of the apparatus shall be constructed of appropriate materials with an uninsulated metal test duct. Tunnel conditions shall be stabilized for a minimum of 30 minutes prior to testing.
- D. Each sprinkler and sprinkler mount shall be allowed to reach ambient temperature for a period of not less than 30 minutes prior to testing.
- E. A timer accurate to ± 0.01 seconds, with suitable controlling devices [e.g., mechanical switch for plunge (start), pressure switch for operation (stop)], shall be utilized to accurately measure the time to operate.

Table 4.28.2. Plunge Test Conditions

Sprinkler Nominal Temperature Rating		Temperature in Test Section		Average Gas (Air) Velocity of Test Section	
°F	(°C)	°F	(°C)	ft/s	(m/s)
135 - 171	(57 - 77)	387 ± 11	(197 ± 6)	8.4 ± 0.2	(2.56 ± 0.07)
174 - 225	(79 - 107)	555 ± 16	(291 ± 9)		
250 - 300	(121 - 149)	765 ± 45	(407 ± 25)		
325 - 375	(163 - 191)	765 ± 45	(407 ± 25)		

- F. In all cases, the RTI shall meet the requirements as stated in Section 4.28.1 when calculated as follows:

$$RTI = \left(\frac{-t_r u^{1/2}}{\ln \left[1 - \Delta T_b (1 + C / u^{1/2}) / \Delta T_g \right]} \right) \cdot [1 + C / u^{1/2}]$$

Where:

- t_r = response time of the sprinkler, in seconds
- u = actual air velocity in the test section of the tunnel (from Table 4.28.2), in ft/s (m/s)
- ΔT_b = mean operating temperature of the sprinkler, as determined in Section 4.8 [Operating Temperature (Liquid Bath)] minus the ambient temperature, in °F (°C)
- ΔT_g = actual gas (air) temperature minus the ambient temperature, in °F (°C)
- C = C-factor as determined in Section 4.27 [Conductivity (C-Factor)], in (ft/s)^{1/2} [(m/s)^{1/2}]

4.29 Sensitivity (Recessed, Flush, and Concealed Types)

4.29.1 Requirement

Recessed, flush and concealed sprinklers shall operate within the maximum response times as calculated in Section 4.29.2A when tested as detailed in Section 4.29.2B, in the least protrusive position possible.

Recessed, flush, and concealed extended coverage hazard category 1 (formerly light hazard) sprinklers shall meet the requirements of quick response sprinklers.

Recessed, flush and concealed sprinklers which have been subjected to tests that require post-exposure sensitivity testing shall be tested at plunge tunnel conditions corresponding to a gas temperature of 387°F (197°C) and a velocity of 8.4 ft/s (2.56 m/s).

4.29.2 Tests/Verification

- A. The maximum response time shall be calculated using the combinations of RTI and C-factor shown in Table 4.29.2.1 and the plunge tunnel conditions detailed in Table 4.29.2.2 for the respective response category. Calculations that return an invalid result shall be disregarded.

Table 4.29.2.1. RTI and C-Factor Combinations

Response Category	RTI		C-Factor		Offset Angle (degrees)
	(ft·s) ^{1/2}	[(m·s) ^{1/2}]	(ft/s) ^{1/2}	[(m/s) ^{1/2}]	
Standard	635	[350]	1.8	[1.0]	0
	455	[250]	3.6	[2.0]	0
	1090	[600]	9.0	[5.0]	15
Quick	90	[50]	1.4	[0.8]	0
	55	[30]	1.8	[1.0]	0
	225	[125]	3.6	[2.0]	25

Table 4.29.2.2. Tunnel Conditions

Response Category	Plunge Tunnel Gas Temperature		Plunge Tunnel Gas Velocity		Applied Vacuum mm Hg
	°F	(°C)	ft/sec	(m/s)	
Standard	275	(135)	8.4	(2.56)	0.007
			11.5	(3.5)	0.007
	387	(197)	8.4	(2.56)	0.010
			11.5	(3.5)	0.010
	555	(291)	8.4	(2.56)	0.013
			11.5	(3.5)	0.013
Quick	275	(135)	8.4	(2.56)	0.007
			11.5	(3.5)	0.007
	387	(197)	8.4	(2.56)	0.010
			11.5	(3.5)	0.010

The maximum permitted sprinkler operating times can be calculated using the following equation:

$$t_{max} = \frac{-RTI \cdot \ln \left[1 - \Delta T_b (1 + C / u^{1/2}) / \Delta T_g \right]}{u^{1/2} \cdot (1 + C / u^{1/2})}$$

Where:

t_{max} = maximum allowed response time of sprinkler, in seconds

RTI = Response Time Index from Table 4.29.2.1, in (ft·s)^{1/2} [(m·s)^{1/2}]

ΔT_b = upper temperature limit of the sprinkler (1.035 x nominal temperature rating) minus an average ambient temperature, in °F (°C)

NOTE: the ambient temperature is considered to be 68°F (20°C) for calculation purposes.

C = C- factor from Table 4.29.2.1, in (ft/s)^{1/2} [(m/s)^{1/2}]

u = actual gas (air) velocity in the test section of the tunnel from Table 4.29.2.2, in ft/s (m/s)

ΔT_g = actual gas (air) temperature, corrected for radiation effects on the temperature sensing device, in the test section (see Table 4.29.2.2) minus the ambient temperature, in °F (°C)

- B. For calculations that return valid results, three samples shall be tested at the corresponding tunnel conditions/offset angle. Compliance with the requirements for maximum operating time shall be

determined by operating sprinkler samples in the plunge tunnel, using the modified plunge tunnel test plate described in Figure D-10.

The sprinklers shall be tested in both the best case orientation and the worst case orientation as if the sprinkler was a pendent sprinkler. For the worst case orientation, the angular offset shall be 15 degrees for standard response sprinklers and 25 degrees for quick response (see Table 4.29.2.1).

Unless the sprinkler design prevents it, a vacuum in accordance with Table 4.29.2.2 shall be applied to and maintained in the upper enclosure of the modified plunge tunnel test plate (Figure D-10).

4.30 Sensitivity (Air Oven)

4.30.1 Requirement

New, uncoated sprinklers which cannot be tested in the plunge tunnel shall operate within a time limit not exceeding the maximum permitted in Table 4.30.1.1 for the respective nominal temperature rating.

New sprinklers having corrosion resistant coatings (decorative, wax, etc.), which cannot be tested in the plunge tunnel, shall operate within a time limit not exceeding the maximum permitted in Table 4.30.1.2 for the respective nominal temperature rating.

Sprinklers having corrosion resistant coatings (decorative, wax, etc.), which cannot be tested in the plunge tunnel, and have been subjected to environmental testing, shall operate within the limits stated in Table 4.30.1.3.

Table 4.30.1.1. Air Oven Sprinkler Sensitivity for New, Uncoated Sprinklers Utilizing the Time vs. Temperature Data per Table 4.30.2

Sprinkler Nominal Temperature Rating		Maximum Operating Temperature		Maximum Operating Time
°F	(°C)	°F	(°C)	min:sec
135 - 170	(57 - 76)	525	(274)	1:15
175 - 225	(79 - 107)	550	(288)	1:45
250 - 300	(121 - 149)	575	(302)	3:00
325 - 375	(163 - 191)	605	(319)	5:00
400 - 475	(204 - 246)	640	(338)	7:30
500 - 575	(260 - 302)	735	(391)	15:00

Table 4.30.1.2. Air Oven Sprinkler Sensitivity for New Sprinklers Having Corrosion Resistant Coating Utilizing the Time vs. Temperature Data per Table 4.30.2

Sprinkler Nominal Temperature Rating		Maximum Operating Temperature		Maximum Operating Time
°F	(°C)	°F	(°C)	min:sec
135 - 170	(57 - 76)	527	(275)	1:34
175 - 225	(79 - 107)	559	(293)	2:11
250 - 300	(121 - 149)	586	(308)	3:45
325 - 375	(163 - 191)	622	(328)	6:15
400 - 475	(204 - 246)	664	(351)	9:22
500 - 575	(260 - 302)	786	(419)	18:45

Table 4.30.1.3. Air Oven Sprinkler Sensitivity for Aged or Elevated Temperature Exposed Sprinklers Having Corrosion Resistant Coating Utilizing the Time vs. Temperature Data per Table 4.30.2

Sprinkler Nominal Temperature Rating		Maximum Operating Temperature		Maximum Operating Time
°F	(°C)	°F	(°C)	min:sec
135 - 170	(57 - 76)	555	(291)	2:00
175 - 225	(79 - 107)	575	(302)	3:00
250 - 300	(121 - 149)	605	(319)	5:00
325 - 375	(163 - 191)	645	(341)	8:00
400 - 475	(204 - 246)	670	(355)	10:00
500 (260) and Over		to be evaluated on a case-by-case basis		

4.30.2 Tests/Verification

Ten previously untested sprinklers of each nominal temperature rating shall be individually operated in an air oven with the inlet of the sprinkler pressurized to the minimum operating pressure in accordance with Table 4.25.1. The rate-of-temperature-rise within the oven shall be controlled in accordance with Table 4.30.2.

Table 4.30.2. Time vs. Temperature Points for air Oven Sprinkler Sensitivity Test

Time min:sec	Temp		Time min:sec	Temp		Time min:sec	Temp	
	°F	(°C)		°F	(°C)		°F	(°C)
0:15	275	(135)	6:00	620	(327)	16:00	750	(399)
0:30	410	(210)	7:00	630	(332)	17:00	765	(407)
0:45	475	(246)	8:00	645	(341)	18:00	778	(414)
1:00	505	(263)	9:00	660	(349)	19:00	790	(421)
1:15	525	(274)	10:00	670	(354)	20:00	805	(429)
1:30	540	(282)	11:00	685	(363)	22:00	830	(443)
2:00	555	(290)	12:00	695	(368)	24:00	855	(457)
3:00	575	(302)	13:00	710	(377)	26:00	880	(471)
4:00	590	(310)	14:00	725	(385)	28:00	905	(485)
5:00	605	(318)	15:00	735	(391)	30:00	930	(499)

4.31 Distribution - Standard Coverage Sprinklers

4.31.1 Requirement

- A. Upright and pendent standard coverage sprinklers shall be capable of distributing water in a uniform manner. Samples shall be tested as detailed in Section 4.31.2.A and shall meet the requirements in Table 4.31.2 for the appropriate nominal K-factor. For each test condition, not more than one individual pan shall have a collection less than the minimum required. Dry pans (i.e., zero water collection) are not permitted.
- B. Standard sidewall sprinklers (horizontal and vertical) shall be tested as detailed in Section 4.31.2.B. The amount of water collected in any individual pan shall not be less than 0.030 gal/min/ft² (1.22 mm/min) and the average collection shall not be less than 0.050 gal/min/ft² (2.04 mm/min), for the area covered. EXCEPTION: Up to two non-adjacent pans may have a collection less than 0.030 gal/min/ft² (1.22 mm/min). Dry pans (i.e., zero water collection) are not permitted. Sidewall sprinklers shall provide a minimum of 3.5 percent of the total discharge [i.e., at least 0.525 gal/min (1.99 L/min) in the 10 ft (3.05 m) span between sprinklers] against the back wall

and shall wet the back wall completely from the floor up to 4 feet (1.2 m) below the deflector. No dry areas are allowed within that region.

- C. Sprinklers with factory painted or decorative finishes, such as plating, shall comply with the same performance criteria as those without such finishes.
- D. When sprinklers are fitted with protective guards, such guards shall not degrade the average collection by more than 20 percent. Minimum average and individual pan requirements shall be ignored. However, dry pans are not permitted.
- E. For sprinklers with corrosion resistant coatings such as wax, prior to the distribution tests, the coated samples shall be operated in the air oven (Section 4.30) and exposed for the maximum operating time for the appropriate temperature rating as stated in Table 4.30.1.2. The presence of a corrosion resistant coating shall not degrade the average collection by more than 10 percent. Minimum individual pan requirements shall be ignored. However, dry pans are not permitted.

4.31.2 Tests/Verification

The appropriate number of previously untested samples shall be subjected to the distribution test conditions detailed in Table 4.31.2 for the type of sprinkler under examination. All samples shall be provided completely assembled. Prior to distribution testing, the sprinklers shall be operated, using a suitable heat source, to remove the heat responsive assembly. In cases where adjustment of the distance between the deflector and the ceiling or wall is possible, (e.g., recessed type), the distribution tests shall be conducted at both extremes of deflector position.

A. Upright and Pendent Sprinklers

The water discharge from four and six sprinklers shall be collected in sixteen 1 ft² (0.09 m²) pans positioned as shown in Figure D-11. The piping configurations for upright and pendent sprinklers are shown in Figures D-12, D-13 and D-14. Water shall be collected for a period of not less than three minutes in accordance with the conditions detailed in Table 4.31.2.

Upright sprinklers shall be tested utilizing the branch lines shown in Figure D-12, and located below a suspended ceiling. Unless deemed otherwise by the certification agency, all pendent sprinklers shall be installed in their intended installation position utilizing a suspended ceiling and supplied with water from branch lines located above the ceiling (Figure D-13 and D-14).

Exception: Sprinklers intended for use in high temperature ovens may be installed directly into tees for the purpose of distribution testing. In cases where adjustment of the distance between the deflector and the ceiling is possible, (e.g., recessed type), the distribution tests shall be conducted at both extremes of deflector position. Sprinklers shall be installed such that their deflectors are positioned 7.5 ft (2.3 m) from the top plane of the pan array. Sprinklers shall be randomly selected and installed with the frame arms parallel to the branch line pipe. Repositioning of sprinklers, or placing specific sprinklers in specific locations, is not permitted.

Table 4.31.2. Distribution Requirements

Nominal K-Factor in.	Number of Sprinklers	Average Water Flow per Sprinkler		Minimum Average Collection		Minimum Individual Pan	
		gal/min	(L/min)	gal/min/ft ²	(mm/min)	gal/min/ft ²	(mm/min)
2.8	4	6.4	(24.2)	0.064	(2.6)	0.050	(2.0)
	4	8.3	(31.4)	0.083	(3.4)	0.060	(2.4)
	4	12.0	(45.4)	0.120	(4.9)	0.090	(3.7)
	6	8.3	(31.4)	0.083	(3.4)	0.060	(2.4)
5.6	4	12.8	(48.4)	0.128	(5.2)	0.095	(3.9)
	4	16.6	(62.8)	0.166	(6.8)	0.125	(5.1)
	4	24.0	(90.8)	0.240	(9.8)	0.180	(7.3)
	6	16.6	(62.8)	0.166	(6.8)	0.125	(5.1)

<i>Nominal K-Factor in.</i>	<i>Number of Sprinklers</i>	<i>Average Water Flow per Sprinkler</i>		<i>Minimum Average Collection</i>		<i>Minimum Individual Pan</i>	
		<i>gal/min</i>	<i>(L/min)</i>	<i>gal/min/ft²</i>	<i>(mm/min)</i>	<i>gal/min/ft²</i>	<i>(mm/min)</i>
8.0	4	17.9	(67.8)	0.179	(7.3)	0.135	(5.5)
	4	23.2	(87.8)	0.232	(9.4)	0.175	(7.1)
	4	33.6	(127.2)	0.336	(13.7)	0.250	(10.2)
	6	23.2	(87.8)	0.232	(9.4)	0.175	(7.1)
11.2	4	35.5	(134.4)	0.355	(14.7)	0.265	(11.0)
	4	50.0	(189.3)	0.500	(20.4)	0.375	(15.3)
	6	36.0	(136.3)	0.360	(14.7)	0.270	(11.0)
	6	50.0	(189.3)	0.500	(20.4)	0.375	(15.3)
14.0	4	37.5	(142.0)	0.375	(15.3)	0.280	(11.4)
	4	60.3	(228.3)	0.603	(24.6)	0.450	(18.3)
	6	37.5	(142.0)	0.375	(15.3)	0.280	(11.4)
	6	60.3	(228.3)	0.603	(24.6)	0.450	(18.3)
16.8	4	44.4	(168.4)	0.444	(18.1)	0.330	(13.4)
	4	73.2	(277.5)	0.732	(29.8)	0.550	(22.4)
	6	44.5	(168.4)	0.445	(18.1)	0.335	(13.6)
	6	73.3	(277.5)	0.733	(29.9)	0.550	(22.4)

NOTE: For upright sprinklers in the 6-sprinkler test, the requirements apply only to the two rows of pans furthest from the pipe. The two middle rows shall be omitted from the collection results and are exempted due to the unavoidable pipe shadow.

B. Sidewall Sprinklers

1. Floor Collection – One hundred pans, each with a collection area measuring 12 x 12 in. (305 x 305 mm) shall be arranged in a 10 x 10 ft (3.05 x 3.05 m) square, centered between two sidewall sprinklers installed 10 ft (3.05 m) apart. The pans shall cover an area 2 to 12 ft (0.6 to 3.7 m) outward from the wall. For vertical type sidewall sprinklers, the tops of the pans shall be located 6 ft. 8 in. (2.03 m) below the deflectors. For horizontal type sidewall sprinklers, the tops of the pans shall be located 6 ft. 8 in. (2.03 m) below the projected axial centerline of the orifice (see Figure D-15). For either type, the deflector shall be located 6 in. (153 mm) from the wall and 4 in. (100 mm) from the ceiling as shown in Figure D-16. Each sprinkler shall flow water at a rate of 15 gal/min (56.8 L/min) and water shall be collected for a period of not less than three minutes.
2. Back-Wall Collection and Wetting – During the floor collection test, a measurement of the quantity of water being discharged onto the wall behind the sprinkler shall be made. Water shall be collected from the area of the back wall between the two sprinklers by means of a single row of 2 in. (51 mm) wide collecting pans, or other collection apparatus, such as a channel abutting the back wall. The opening in the top of the collection apparatus shall be located not more than 18 in. (457 mm) above the floor. The back wall shall be visually inspected for complete wetting in accordance with the requirements of Section 4.31.1.B.

4.32 Distribution – Extended Coverage Hazard Category 1 (HC-1) Sprinklers

4.32.1 Requirement

When tested as detailed in Section 4.32.2 and using the conditions in Tables 4.32.2.1 and 4.32.2.2, extended coverage hazard category 1 sprinklers shall perform satisfactorily in all coverage areas indicated. The distribution collection shall exhibit the following:

- No dry pans (i.e., zero water collection)

- Not more than one pan with water collection less than 0.015 gal/min/ft² (0.61 mm/min)
- Average collection of all pans not less than 0.040 gal/min/ft² (1.63 mm/min); and,
- Complete wall wetting up to 3 ft (0.9 m) from the floor on all walls. No dry areas shall be permitted within this region.

4.32.2 Tests/Verification

The collection pan array is shown in Figure D-17 and consists of water collection pans measuring 19.7 in x 19.7 in. (0.5 m x 0.5 m). For upright and pendent sprinklers, water distribution shall be measured and recorded for one quadrant of the coverage area. For sidewall sprinklers, water distribution shall be measured and recorded for one half of the coverage area. If visual observation indicates a non-symmetrical distribution pattern, water distribution shall be measured and recorded for the entire coverage area. Wall wetting shall be verified using a 4 ft (1.2 m) high wall enclosing the coverage area and covered with paper as needed for visual verification. Water shall be collected for a period of not less than 6 minutes.

In cases where adjustment of the distance between the deflector and the ceiling is possible, (i.e., recessed type), distribution tests shall be conducted at both extremes of deflector position.

Table 4.32.2.1. Distribution Test Conditions for Upright and Pendent Extended Coverage Hazard Category 1 Sprinklers

Nominal K-Factor	Coverage Area		Deflector to Ceiling Distance		Flow Rate		End Head Pressure	
	ft x ft	(m x m)	in.	(m)	gal/min	(L/min)	psi	(bar)
5.6	16 x 16	(4.9 x 4.9)	4	(0.10)	26	(100)	22	(1.5)
	18 x 18	(5.5 x 5.5)	4	(0.10)	33	(125)	35	(2.4)
	20 x 20	(6.1 x 6.1)	4	(0.10)	40	(150)	51	(3.5)
8.0	16 x 16	(4.9 x 4.9)	4	(0.10)	26	(100)	11	(0.8)
	18 x 18	(5.5 x 5.5)	4	(0.10)	33	(125)	17	(1.2)
	20 x 20	(6.1 x 6.1)	4	(0.10)	40	(150)	25	(1.7)
11.2	16 x 16	(4.9 x 4.9)	4	(0.10)	30	(115)	7	(0.5)
	18 x 18	(5.5 x 5.5)	4	(0.10)	33	(125)	9	(0.6)
	20 x 20	(6.1 x 6.1)	4	(0.10)	40	(150)	13	(0.9)
14.0	16 x 16	(4.9 x 4.9)	4	(0.10)	37	(139)	7	(0.5)
	18 x 18	(5.5 x 5.5)	4	(0.10)	37	(139)	7	(0.5)
	20 x 20	(6.1 x 6.1)	4	(0.10)	40	(150)	8	(0.5)

Table 4.32.2.2. Distribution Test Conditions for Sidewall Extended Coverage Hazard Category 1 Sprinklers

Nominal K-Factor	Coverage Area		Deflector to Ceiling Distance		Flow Rate		End Head Pressure	
	ft x ft	(m x m)	in.	(m)	gal/min	(L/min)	psi	(bar)
5.6	16 x 16	(4.9 x 4.9)	4 and 12	(0.10 and 0.30)	26	(100)	22	(1.5)
	16 x 18	(4.9 x 5.5)	4 and 12	(0.10 and 0.30)	30	(115)	29	(2.0)
	16 x 20	(4.9 x 6.1)	4 and 12	(0.10 and 0.30)	33	(125)	35	(2.4)
8.0	16 x 16	(4.9 x 4.9)	4 and 12	(0.10 and 0.30)	32	(120)	16	(1.1)
	16 x 18	(4.9 x 5.5)	4 and 12	(0.10 and 0.30)	36	(135)	20	(1.4)
	16 x 20	(4.9 x 6.1)	4 and 12	(0.10 and 0.30)	40	(150)	25	(1.7)
	16 x 22	(4.9 x 6.7)	4 and 12	(0.10 and 0.30)	44	(165)	30	(2.0)
	16 x 24	(4.9 x 7.3)	4 and 12	(0.10 and 0.30)	48	(180)	36	(2.5)

4.33 Distribution - K14.0 (K200) Non-Storage Extended Coverage Horizontal Sidewall Sprinklers

4.33.1 Requirement

K14.0 (K200) non-storage extended coverage horizontal sidewall sprinklers shall be capable of distributing water in a uniform manner. Samples shall be tested as detailed in Section 4.33.2.

- In the 14 ft wide x 12.5 ft long (4.3 m wide x 3.8 m long) area of coverage:
- The average distribution collection shall be greater than or equal to 0.088 gal/min/ft² (3.59 mm/min).
- The lowest single pan collection shall be greater than or equal to 0.033 gal/min/ft² (1.35 mm/min).
- As an exception to the lowest single pan requirement, no more than two pans may have collection below 0.033 gal/min/ft² (1.35 mm/min). Dry pans are not permitted.
- In the area located under the beam:
- The lowest single pan collection shall be greater than or equal to 0.008 gal/min/ft² (0.33 mm/min).

4.33.2 Tests/Verification

Tests shall be conducted using a single sprinkler operating at a nominal discharge pressure of 7.4 psi (0.5 bar), which corresponds to a nominal discharge density of 0.22 gal/min/ft² (8.96 mm/min). The sprinkler shall be connected to a nominal 2 in. diameter Schedule 40 branch line with a nominal 2 in. x 2 in. x 1¼ in. diameter tee. The sprinkler shall be installed into the tee through a nominal 1¼ in. x ¾ in. diameter bushing. The sprinkler ceiling-to-orifice centerline shall be approximately 11 in. (28 cm). Collection shall be taken in 1.64 ft x 1.64 ft (0.5 m x 0.5 m) pans.

- A. A distribution test shall be conducted with the sprinkler deflector positioned 17 ft (5.2 m) from the top of the collection pans. Water shall be collected in at least one half of the area of coverage, with approximately 12.75 in. (32 cm) of the coverage area located behind the vertical plane of the sprinkler orifice. This represents a maximum horizontal distance, D, of 18 in. (46 cm) (see Figure D-18) between the orifice planes of back-to-back sprinklers, with a 3.75 in. (9.5 cm) coverage area overlap. Alternately, it represents a maximum horizontal distance, A, of 4 in. (10.2 cm) (see Figure D-18) from the plane of the sprinkler orifice beyond the outermost edge of the widest permissible bottom beam flange.
- B. The test described in Section 4.34.2.A shall be repeated with a distance from sprinkler deflector to top of pans, H, of 10 ft (3 m) (see Figure D-18). This represents the minimum allowable vertical clearance to commodity.
- C. Next, a screen shall be placed behind and below the sprinkler to represent a bottom flange beam obstruction with the outer edge of the flange 1 in. (2.5 cm) behind the plane of the orifice (i.e. A = 1 in.) and located 7 ft 4 in. (2.24 m) down from the sprinkler deflector. Collection shall be taken in at least one half of the 14 ft (4.3 m) wide coverage area, with at least 1 row of collection pans both in front of and behind the screen.

4.34 Impingement (Angle of Protection)

4.34.1 Requirement

In-rack sprinklers shall be so designed as to provide an "angle of protection" for the heat responsive assembly against direct impingement or run-off water from the shield caused by the discharge from neighboring sprinklers installed at higher elevations.

The "angle of protection" created by the water shield, as indicated in Figure D-1, shall not exceed 45 degrees. Where unusual geometry or method of mounting the shield to the sprinkler exists, additional tests may be conducted as deemed necessary by the certification agency. Protective guards incorporating shields shall also be subjected to this test.

4.34.2 Tests/Verification

Measure the angle in accordance with Figure D-1.

4.35 Actual Delivered Density (ADD) - Extended Coverage Sprinklers for Protection of Hazard Categories 1 – 3 (HC-1 through HC-3)

4.35.1 Requirement

K11.2 (K160) and K14.0 (K200) extended coverage hazard category 1 – 3 sprinklers shall meet the requirements stated in Tables 4.35.1a and b respectively for the tests described in Section 4.35.2 when tested in the ADD/PWD apparatus.

Table 4.35.1a. ADD Measurements for K11.2 (K160) Extended Coverage Hazard Category 1 – 3 Sprinklers

<i>Sprinkler Orientation</i>	<i>Number of Sprinklers Centered Over the ADD Apparatus</i>	<i>Sprinkler Spacing ft (m)</i>	<i>Pipe Spacing ft (m)</i>	<i>Ceiling Clearance to Water Collection Pans ft (m)</i>	<i>Freeburn Conv. Heat Release kBTU/min (MW)</i>	<i>Pressure psi (bar)</i>	<i>Center Pan Area Average Density gal/min/ft² (mm/min)</i>	<i>Pre-Wetting Area Average Density gal/min/ft² (mm/min)</i>
Upright	1	-	-	3.5	0	12	0.13	0.12
		-	-	(1.1)	(0)	(0.8)	(5.3)	(4.9)
	1	-	-	10	28	12	0.05	0.03
		-	-	(3.1)	(0.5)	(0.8)	(2.0)	(1.2)
	2	16	-	3.5	0	12	0.10	0.10
		(4.9)	-	(1.1)	(0)	(0.8)	(4.1)	(4.1)
	2	16	-	10	62	12	0.08	0.05
		(4.9)	-	(3.1)	(1.1)	(0.8)	(3.3)	(2.0)
	4	16	16	3.5	0	12	0.13	0.11
		(4.9)	(4.9)	(1.1)	(0)	(0.8)	(5.3)	(4.5)
	4	16	16	10	85	12	0.11	0.13
		(4.9)	(4.9)	(3.1)	(1.5)	(0.8)	(4.5)	(5.3)
Pendent	1	-	-	3.5	0	12	0.11	0.05
		-	-	(1.1)	(0)	(0.8)	(4.5)	(2.0)
	1	-	-	10	28	12	0.02	0.02
		-	-	(3.1)	(0.5)	(0.8)	(0.8)	(0.8)
	2	16	-	3.5	0	12	0.12	0.12
		(4.9)	-	(1.1)	(0)	(0.8)	(4.9)	(4.9)
	2	16	-	10	62	12	0.06	0.08
		(4.9)	-	(3.1)	(1.1)	(0.8)	(2.4)	(3.3)
	4	16	16	3.5	0	12	0.16	0.12
		(4.9)	(4.9)	(1.1)	(0)	(0.8)	(6.5)	(4.9)
	4	16	16	10	85	12	0.13	0.14
		(4.9)	(4.9)	(3.1)	(1.5)	(0.8)	(5.3)	(5.7)

Table 4.35.1b. ADD Measurements for K14.0 (K200) Extended Coverage Hazard Category 1 – 3 Sprinklers

Sprinkler Orientation	Number of Sprinklers Centered Over the ADD Apparatus	Sprinkler Spacing ft (m)	Pipe Spacing ft (m)	Ceiling Clearance to Water Collection Pans ft (m)	Freeburn Conv. Heat Release kBTU/min (MW)	Pressure psi (bar)	Center Pan Area Average Density gal/min/ft ² (mm/min)	Pre-Wetting Area Average Density gal/min/ft ² (mm/min)
Upright	1	-	-	3.5	0	18	0.16	0.14
		-	-	(1.1)	(0)	(1.3)	(6.5)	(5.7)
	1	-	-	10	28	18	0.06	0.05
		-	-	(3.1)	(0.5)	(1.3)	(2.4)	(2.0)
	2	20	-	3.5	0	18	0.12	0.07
		(6.1)	-	(1.1)	(0)	(1.3)	(4.9)	(2.9)
	2	20	-	10	74	18	0.11	0.06
		(6.1)	-	(3.1)	(1.3)	(1.3)	(4.5)	(2.4)
	4	20	20	3.5	0	18	0.15	0.07
		(6.1)	(6.1)	(1.1)	(0)	(1.3)	(6.1)	(2.9)
	4	20	20	10	97	18	0.15	0.12
		(6.1)	(6.1)	(3.1)	(1.7)	(1.3)	(6.1)	(4.9)
Pendent	1	-	-	3.5	0	18	0.10	0.05
		-	-	(1.1)	(0)	(1.3)	(4.1)	(2.0)
	1	-	-	10	28	18	0.02	0.02
		-	-	(3.1)	(0.5)	(1.3)	(0.8)	(0.8)
	2	20	-	3.5	0	18	0.10	0.16
		(6.1)	-	(1.1)	(0)	(1.3)	(4.1)	(6.5)
	2	20	-	10	74	18	0.06	0.07
		(6.1)	-	(3.1)	(1.3)	(1.3)	(2.4)	(2.9)
	4	20	20	3.5	0	18	0.13	0.14
		(6.1)	(6.1)	(1.1)	(0)	(1.3)	(5.3)	(5.7)
	4	20	20	10	97	18	0.18	0.14
		(6.1)	(6.1)	(3.1)	(1.7)	(1.3)	(7.3)	(5.7)

4.35.2 Tests/Verification

Actual Delivered Density (ADD) and Pre-Wetting Density (PWD) measurements shall be taken using the test apparatus shown in Figures D-19 and D-20. The ADD/PWD apparatus shall consist of two major components: a fire source and a simulated commodity. The fire source shall consist of a number of spray nozzles equally spaced on the circumference of a circle. Heptane shall be used as the fuel for the fire. Approximately 6 in. (152 mm) below the fire source shall be an array of collection pans representing a simulated commodity.

The center section of the array shall approximate the geometry and size of a single tier rack-storage commodity of two pallet loads deep by two pallet loads wide, with a 6 in. (15.2 cm) flue space between each pallet. Sixteen square water collection pans, representing the top surface of the commodity within the ignition area, shall collect water that would normally reach the commodity’s top surface. Four additional pans, representing the flue spaces between pallet loads of commodity, shall collect water that would normally be delivered to the flue spaces.

At each end of the center section of the array, a set of Pre-Wetting Density (PWD) pans shall be positioned. Each set of pans shall approximate the geometry and size of one-half of one tier of rack-storage commodity (two pallet loads deep by one pallet load wide), with a 6 in. (15.2 cm) flue space between adjacent pallets. At each end of the center section, eight square collection pans, representing the commodity just beyond the area of ignition, shall collect water that would normally reach the top surface of the adjacent commodity. Three rectangular pans at each end,

representing the flue spaces between pallet loads, shall collect water that would normally be delivered to the adjacent flue spaces.

A flat horizontal ceiling with minimum dimensions of 36.5 x 33.5 ft (11.13 x 10.21 m) shall be suspended above the apparatus. The test apparatus shall be located in a room of sufficient volume to minimize the entrainment of additional water spray.

Open sprinklers shall be connected to nominal 2 in. sprinkler pipes under the suspended ceiling via 2 in. x 2 in. x 3/4 in. nominal threaded tees, threadolet fittings with bushings, or a suitable alternative. When connecting sprinklers having nominal 1/2 in. NPT threads to threaded tees, nominal 3/4 to 1/2 in. reduction bushings shall be used. The frame arms of each sprinkler shall be aligned parallel with the sprinkler pipe. The distance from the pipe centerline to ceiling shall be 12 in. (30 cm) for upright sprinklers. For pendent sprinklers tested at a clearance from the ceiling to the top of the water collection pans of 3.5 ft (1.07 m), the distance from the pipe centerline to ceiling shall be 2.5 in. (6.4 cm). For pendent sprinklers tested at a clearance from the ceiling to the top of the water collection pans of 10 ft (3.05 m), the distance from the pipe centerline to ceiling shall be 12 in. (30 cm). For all tests, the pipes shall be fed with water flowing from a single direction.

Tests in which the clearance from the ceiling to the top of the water collection pans is 3.5 ft (1.07 m) shall be conducted without a fire. For other tests, prior to each measurement, the heptane spray shall be ignited and the flow stabilized at a flow rate corresponding to the required heat release. Once the fuel flow rate has been stabilized, water shall be discharged from the sprinklers. Water collected by all pans is to be channeled to the collectors of the apparatus. Water shall be collected until one or more collection buckets are filled, or for a minimum of 10 minutes, whichever occurs first, for each test detailed in Section 4.35.1.

For all tests, measurements shall be recorded for up to five different sets of samples.

4.36 Actual Delivered Density (ADD) - K19.6 (K280) Pendent Storage Sprinklers

4.36.1 Requirement

K19.6 (K280) pendent storage sprinklers shall be subjected to the tests in Table 4.36.1 as described in Section 4.36.2 utilizing the ADD/PWD apparatus.

Results of these tests shall be used to determine the least favorable ignition location(s) for full scale fire testing. The least favorable ignition scenario will be identified first by the lowest average density collected in the center area. If this does not differentiate the scenarios significantly (by at least 5 percent), consideration will be given to the average density collected in the pre-wetting area as well. Equivalent tests conducted at pressures below the lowest and/or above the highest specified pressure may be used in place of those specified in Section 4.36.2 if a clear pattern of performance is demonstrated in such tests.

Table 4.36.1 ADD Measurements for K19.6 (K280) Pendent Storage Sprinklers

<i>Number of Sprinklers Centered Over the ADD Apparatus</i>	<i>Sprinkler Spacing ft (m)</i>	<i>Pipe Spacing ft (m)</i>	<i>Ceiling Clearance to Water Collection Pans ft (m)</i>	<i>Freeburn Conv. Heat Release kBTU/min (MW)</i>	<i>Pressure psi (bar)</i>
2	10	-	6	0	25
	(3.1)	-	(1.8)	(0)	(1.7)
2	10	-	6	0	16
	(3.1)	-	(1.8)	(0)	(1.1)
2	10	-	6	114	25
	(3.1)	-	(1.8)	(2)	(1.7)
2	10	-	6	114	16
	(3.1)	-	(1.8)	(2)	(1.1)

<i>Number of Sprinklers Centered Over the ADD Apparatus</i>	<i>Sprinkler Spacing ft (m)</i>	<i>Pipe Spacing ft (m)</i>	<i>Ceiling Clearance to Water Collection Pans ft (m)</i>	<i>Freeburn Conv. Heat Release kBTU/min (MW)</i>	<i>Pressure psi (bar)</i>
4	10	10	6	0	25
	(3.1)	(3.1)	(1.8)	(0)	(1.7)
4	10	10	6	0	16
	(3.1)	(3.1)	(1.8)	(0)	(1.1)
4	10	10	6	114	25
	(3.1)	(3.1)	(1.8)	(2)	(1.7)
4	10	10	6	114	16
	(3.1)	(3.1)	(1.8)	(2)	(1.1)

4.36.2 Tests/Verification

Actual Delivered Density (ADD) and Pre-Wetting Density (PWD) measurements shall be taken using the test apparatus shown in Figures D-19 and D-20. The ADD/PWD apparatus shall consist of two major components: a fire source and a simulated commodity. The fire source shall consist of a number of spray nozzles equally spaced on the circumference of a circle. Heptane shall be used as the fuel for the fire. Approximately 6 in. (152 mm) below the fire source shall be an array of collection pans representing a simulated commodity.

The center section of the array shall approximate the geometry and size of a single tier rack-storage commodity of two pallet loads deep by two pallet loads wide, with a 6 in. (15.2 cm) flue space between each pallet. Sixteen square water collection pans, representing the top surface of the commodity within the ignition area, shall collect water that would normally reach the commodity's top surface. Four additional pans, representing the flue spaces between pallet loads of commodity, shall collect water that would normally be delivered to the flue spaces.

At each end of the center section of the array, a set of Pre-Wetting Density (PWD) pans shall be positioned. Each set of pans shall approximate the geometry and size of one-half of one tier of rack-storage commodity (two pallet loads deep by one pallet load wide), with a 6 in. (15.2 cm) flue space between adjacent pallets. At each end of the center section, eight square collection pans, representing the commodity just beyond the area of ignition, shall collect water that would normally reach the top surface of the adjacent commodity. Three rectangular pans at each end, representing the flue spaces between pallet loads, shall collect water that would normally be delivered to the adjacent flue spaces.

A flat horizontal ceiling with minimum dimensions of 36.5 x 33.5 ft (11.13 x 10.21 m) shall be suspended above the apparatus. The test apparatus shall be located in a room of sufficient volume to minimize the entrainment of additional water spray.

Open sprinklers shall be connected to nominal 2.5 in. sprinkler pipes under the suspended ceiling via 2.5 in. x 2.5 in. x 1 in. nominal threaded tees, threadolet fittings with bushings, or a suitable alternative. The frame arms of each sprinkler shall be aligned parallel with the sprinkler pipe. The piping shall be positioned such that the distance from the ceiling to the geometric center of the heat responsive element of the sprinkler is 12 in. (30 cm) for standard response sprinklers and 13 in. (33 cm) for quick response sprinklers. For all tests, the pipes shall be fed with water flowing from a single direction.

For tests conducted with a fire, prior to each measurement, the heptane spray shall be ignited and the flow stabilized at a flow rate corresponding to the required heat release. Once the fuel flow rate has been stabilized, water shall be discharged from the sprinklers. Water collected by all pans is to be channeled to the collectors of the apparatus. Water shall be collected until one or more collection buckets are filled, or for a minimum of 10 minutes, whichever occurs first, for each test detailed in Section 4.36.1.

For all tests, measurements shall be recorded for up to five different sets of samples.

4.37 Actual Delivered Density (ADD) - K25.2 (K360) Storage Sprinklers

4.37.1 Requirement

K25.2 (K360) storage sprinklers shall be subjected to the tests in Table 4.37.1 as described in Section 4.37.2 utilizing the ADD/PWD apparatus.

Results of these tests shall be used only to determine the least favorable ignition location(s) for full scale fire testing. Minimum collection requirements are not specified. The least favorable ignition scenario will be identified first by the lowest average density collected in the center area. If this does not differentiate the scenarios significantly (by at least 5 percent), consideration will be given to the average density collected in the pre-wetting area as well. Equivalent tests conducted at pressures below the lowest and/or above the highest specified pressure may be used in place of those specified in Table 4.37.1 if a clear pattern of performance is demonstrated in such tests.

Table 4.37.1. ADD Measurements for K25.2 (K360) Storage Sprinklers

Sprinkler Nominal Discharge Coefficient (gal/min/(psi) ^{1/2})	Response Rating	Orientation	Number of Sprinklers Centered Over the ADD Apparatus	Sprinkler Spacing ft (m)	Pipe Spacing ft (m)	Ceiling Clearance to Water Collection Pans ft (m)	Freeburn Convective Heat Release kBTU/min (MW)	Pressure psi (bar)	Direction of Feed Flow
25.2	Standard	Upright	2	12	-	6	150	20	Double
				(3.7)	-	(1.8)	(2.6)	(1.4)	
			4	12	8	6	170	20	Double
				(3.7)	(2.4)	(1.8)	(3.0)	(1.4)	
25.2	Standard	Pendent	2	12	-	6	150	15	Double
				(3.7)	-	(1.8)	(2.6)	(1.0)	
			4	12	8	6	170	15	Double
				(3.7)	(2.4)	(1.8)	(3.0)	(1.0)	
25.2	Quick	EC Upright and Pendent	2	14	-	6	150	30	Double
				(4.3)	-	(1.8)	(2.6)	(2.1)	
			4	14	14	6	170	30	Double
				(4.3)	(4.3)	(1.8)	(3.0)	(2.1)	

4.37.2 Tests/Verification

Actual Delivered Density (ADD) and Pre-Wetting Density (PWD) measurements shall be taken using the test apparatus shown in Figures D-19 and D-20. The ADD/PWD apparatus shall consist of two major components: a fire source and a simulated commodity. The fire source shall consist of a number of spray nozzles equally spaced on the circumference of a circle. Heptane shall be used as the fuel for the fire. Approximately 6 in. (152 mm) below the fire source shall be an array of collection pans representing a simulated commodity.

The center section of the array shall approximate the geometry and size of a single tier rack-storage commodity of two pallet loads deep by two pallet loads wide, with a 6 in. (15.2 cm) flue space between each pallet. Sixteen square water collection pans, representing the top surface of the commodity within the ignition area, shall collect water that would normally reach the commodity's top surface. Four additional pans, representing the flue spaces between pallet loads of commodity, shall collect water that would normally be delivered to the flue spaces.

At each end of the center section of the array, a set of Pre-Wetting Density (PWD) pans shall be positioned. Each set of pans shall approximate the geometry and size of one-half of one tier of rack-storage commodity (two pallet loads deep by one pallet load wide), with a 6 in. (15.2 cm) flue space between adjacent pallets. At each end of the center section, eight square collection pans, representing the commodity just beyond the area of ignition, shall collect water that would normally reach the top surface of the adjacent commodity. Three rectangular pans at each end,

representing the flue spaces between pallet loads, shall collect water that would normally be delivered to the adjacent flue spaces.

A flat horizontal ceiling with minimum dimensions of 36.5 x 33.5 ft (11.13 x 10.21 m) shall be suspended above the apparatus. The test apparatus shall be located in a room of sufficient volume to minimize the entrainment of additional water spray.

For K25.2 (K360) sprinklers, open sprinklers shall be connected to nominal 2.5 in. sprinkler pipes under the suspended ceiling via 2.5 in. x 2.5 in. x 1 in. nominal threaded tees, threadolet fittings with bushings, or a suitable alternative. Sprinklers having larger orifice sizes shall be installed on appropriately sized pipe. The frame arms of each sprinkler shall be aligned parallel with the sprinkler pipe. The piping shall be positioned such that the distance from the ceiling to the geometric center of the heat responsive element of the sprinkler is 12 in. (30 cm) for standard response sprinklers and 13 in. (33 cm) for quick response sprinklers. For all tests, the pipes shall be fed with water flowing from both directions (double feed).

Prior to each measurement, the heptane spray shall be ignited and stabilized at a flow rate corresponding to the required heat release. Once the fuel flow rate has been stabilized, water shall be discharged from the sprinklers. Water collected by all pans is to be channeled to the collectors of the apparatus. Water shall be collected until one or more collection buckets are filled, or for a minimum of 10 minutes, whichever occurs first, for each test detailed in Section 4.37.1.

For all tests, measurements shall be recorded for up to five different sets of samples.

4.38 Fire - Standard Crib

4.38.1 Requirement

Standard coverage K5.6 (K80) and K8.0 (K115) upright and pendent sprinklers shall be subjected to at least the "centered between four sprinklers" fire test described in Section 4.38.2. However, fire tests on other types of sprinklers, or an alternate fire source and/or location, may be required at the sole discretion of the certification agency.

NOTE: Sprinklers intended only for protection of HC-1 occupancies, such as standard coverage K2.8 (K40) sprinklers and K5.6 (K80) sidewall sprinklers, are not fire tested.

The sprinklers shall be capable of controlling a fire within specified temperature and crib weight loss limits.

All of the following requirements shall be met when the sprinklers are tested utilizing a crib centrally located between four sprinklers, with a flow rate per sprinkler of 25 gal/min (95 L/min):

- A. The air temperature at the thermocouple locations shall be reduced to less than 530°F (277°C) above ambient within 6 minutes after ignition.
- B. The mean air temperature at the thermocouple location shall not exceed 530°F (277°C) above ambient during the remaining 24 minutes of the test.
- C. The air temperature at any thermocouple shall not exceed 530°F (277°C) above ambient for any continuous 3 minute period during the remaining 24 minutes of the test.
- D. After the 30-minute test period, the weight loss of the crib shall not exceed 20 percent. Crib weight loss shall be determined on the basis of bone-dry weight (zero percent moisture content) before and after the test.

4.38.2 Tests/Verification

A wood crib weighing approximately 350 lb (160 kg), constructed of saw-finished spruce (*Picea Excelsa*) or fir (*Abies Lasioscapa* or *Pseudotsuga menziesii*) or equivalent lumber as shown in Figure D-21, shall be conditioned and weighed prior to the test. Moisture content shall be measured prior to the test and shall not exceed an average of 10 percent.

- A. Sprinklers shall be installed over the wood crib on 10 ft x 10 ft (3.05 m x 3.05 m) spacing as described in Figures D-22 and D-23. Upright sprinklers shall be installed with their deflectors 10

in. \pm 4 in. (250 mm \pm 100 mm) from the ceiling, directly into nominal 2 in. tees on nominal 2 in. diameter schedule 40 pipe. Pendent, recessed, flush and concealed sprinklers shall be installed into the appropriately sized coupling on nominal 1 in. diameter drops from nominal 2 in. diameter schedule 40 pipe. For recessed, flush and concealed type sprinklers, a false ceiling shall be used to simulate actual installation. Sprinklers having exposed deflectors shall be installed with their deflectors located 7.5 ft (2.3 m) from the top of the crib. For flush and concealed type sprinklers, the false ceiling surface shall be located 7.5 ft (2.3 m) from the top of the crib. Sprinkler frame arms or deflector support pins shall be orientated parallel to the piping whenever possible. The test shall be conducted using sprinklers with a nominal temperature rating between 135 and 170°F (57 and 70°C) so as to permit operation of all sprinklers within 70 seconds after ignition.

- B. A continuous flow of n-heptane shall be discharged at the rate of 1 gal/min (3.785 L/min) through a spray nozzle with a pattern having a cone angle of approximately 75 degrees when atomizing the fuel. The nozzle shall be a Delvan WS-15 industrial nozzle produced by Delvan Manufacturing Co., West Des Moines, IA 50265 USA, or equivalent. The n-heptane shall be kept continuously ignited for a period of 30 minutes by a pilot flame or igniter placed within 2 in. (50 mm) of the spray nozzle.
- C. Ceiling temperature over the crib shall be measured utilizing 4 thermocouples spaced 1 in. (25 mm) apart and located approximately 2 in. (50 mm) below the ceiling. The thermocouples shall be positioned centrally with respect to the sprinklers, with their tips turned upward to prevent the formation of water droplets during testing.
- D. Following the test, the crib shall be conditioned for at least 4 days or until the moisture content at any location is less than 8 percent. The crib shall then be weighed. The actual crib weight loss shall be determined from the pre- and post-test weights, corrected for moisture content.

4.39 Fire Tests - K11.2 (K160) Upright and Pendent Storage Sprinklers

4.39.1 Requirement

K11.2 (K160) upright and pendent storage sprinklers shall perform satisfactorily in full-scale fire test scenarios as detailed in Section 4.39.2 within the limits stated in Table 4.39.1.

Table 4.39.1. K11.2 (K160) Storage Sprinkler Fire Test Limits

<i>Test</i>	<i>A</i>	<i>B</i>
Peak/Maximum One Minute Average Steel Temperature; °F (°C)	1200/1000 (649/538)	1200/1000 (649/538)
Aisle Jump/Fire Spread	See below*	See below*
Equivalent Maximum Number of Pallet Loads Consumed	20	10
Maximum Number of Sprinklers to Operate**	20	20

* Fire spread must be confined to the length of the main array. Fire spread to the ends of the main array or to a target array is not permitted.

** Sprinklers installed along the perimeter of the ceiling are not permitted to operate.

4.39.2 Tests/Verification

The tests detailed in this section shall be conducted in an indoor fire test facility with an adjustable ceiling. Sprinklers shall be installed at the spacing indicated in Table 4.39.2, on nominal 2 in. diameter Schedule 40 sprinkler pipes. The pipes shall be oriented perpendicular to the length of the test array and positioned such that the sprinklers are centered about the geometric center of the ceiling. Ignition shall be accomplished using a standard igniter and shall take place at the bottom of the first tier of the test array, located as described in the appropriate figure listed in Table 4.39.2. Temperatures shall be monitored by thermocouples located at the ceiling. Two-way, 42 in.

x 42 in. x 5 in. (107 cm x 107 cm x 12.7 cm), slatted hardwood pallets shall support the commodity.

Table 4.39.2. K11.2 (K160) Storage Sprinklers Test Scenarios

<i>Test</i>	<i>A</i>	<i>B</i>
Storage Type	Double-Row Rack	Double-Row Rack
Fuel (Standard Commodity)	Class 2	Cartoned Unexpanded Plastic
Test Array	see Figure D-24	see Figure D-25
Nominal Array Height, ft (m)	19 (5.8)	14 (4.3)
Nominal Ceiling Height, ft (m)	30 (9.1)	25 (7.6)
Nominal Clearance-to-ceiling ft (m)	11 (3.4)	11 (3.4)
Ignition	Between 4 sprinklers	Below 1 sprinkler
Sprinkler Nominal Temperature Rating, °F(°C)	160 (70)	160 (70)
Sprinkler Spacing ft x ft (m x m)	10 x 10 (3.0 x 3.0)	8 x 10 (2.4 x 3.0)
Deflector to Ceiling, in. (mm)	7 (178) upright 12 (305) pendent	7 (178) upright 12 (305) pendent
Sprinkler Thermal Sensitivity	Standard Response	Standard Response
Water Pressure, psi (bar)	11 (0.8)	19 (1.3)
Test Duration (min)	30	30

4.40 Fire Tests - K14.0 (K200) Upright and Pendent Storage Sprinklers

4.40.1 Requirement

K14.0 (K200) upright and pendent storage sprinklers shall perform satisfactorily in full-scale fire test scenarios as detailed in Section 4.40.2 within the limits stated in Table 4.40.1.

Table 4.40.1. K14.0 (K200) Storage Sprinkler Fire Test Limits

<i>Test</i>	<i>A</i>	<i>B</i>	<i>C</i>
Peak/Maximum One Minute Average Steel Temperature, °F (°C)	1200/1000 (649/538)	1200/1000 (649/538)	1200/1000 (649/538)
Aisle Jump/Fire Spread	See below*	See below*	See below*
Equivalent Maximum Number of Pallet Loads Consumed	20	20	10
Maximum Number of Sprinklers to Operate**	20	20	20

* Fire spread must be confined to the length of the main array. Fire spread to the ends of the main array or to a target array is not permitted.

** Sprinklers installed along the perimeter of the ceiling are not permitted to operate.

4.40.2 Tests/Verification

The tests detailed in this section shall be conducted in an indoor fire test facility with an adjustable ceiling. Sprinklers shall be installed at the spacing indicated in Table 4.40.2, on nominal 2 in. diameter Schedule 40 sprinkler pipes. The pipes shall be oriented perpendicular to the length of

the test array and positioned such that the sprinklers are centered about the geometric center of the ceiling. Ignition shall be accomplished using a standard igniter and shall take place at the bottom of the first tier of the test array, located as described in the appropriate figure listed in Table 4.40.2. Temperatures shall be monitored by thermocouples located at the ceiling. Two-way, 42 in. x 42 in. x 5 in. (107 cm x 107 cm x 12.7 cm), slatted hardwood pallets shall support the commodity.

Table 4.40.2. K14.0 (K200) Storage Sprinkler Test Scenarios

<i>Test</i>	<i>A</i>	<i>B</i>	<i>C</i>
Storage Type	Double-Row Rack	Double-Row Rack	Palletized
Fuel (Standard Commodity)	Class 2	Cartoned Unexpanded Plastic	Cartoned Unexpanded Plastic
Test Array	see Figure D-24	see Figure D-25	see Figure D-26
Nominal Array Height ft (m)	19 (5.8)	14 (4.3)	15 (4.6)
Nominal Ceiling Height, ft (m)	30 (9.1)	25 (7.6)	25 (7.6)
Nominal Clearance-to-Ceiling, ft (m)	11 (3.4)	11 (3.4)	10 (3.05)
Ignition	Between 4 sprinklers	Below 1 sprinkler	Between 4 sprinklers
Sprinkler Nominal Temperature Rating, °F(°C)	160 (70)	160 (70)	280 138
Sprinkler Spacing ft x ft (m x m)	10 x 10 (3.0 x 3.0)	8 x 10 (2.4 x 3.0)	8 x 10 (2.4 x 3.0)
Deflector to Ceiling, in. (mm)	7 (178) upright 12 (305) pendent	7 (178) upright 12 (305) pendent	7 (178) upright 12 (305) pendent
Sprinkler Thermal Sensitivity	Standard Response	Standard Response	Standard Response
Water Pressure, psi (bar)	7 (0.5)	12 (0.8)	12 (0.8)
Test Duration (min)	30	30	30

4.41 Fire Tests - K14.0 (K200) Extended Coverage Sprinklers for Protection of Hazard Categories 1 – 3 (HC-1 through HC-3)

4.41.1 Requirement

K14.0 (K200) extended coverage upright and pendent sprinklers for protection of hazard categories 1 – 3 (HC-1 through HC-3) shall perform satisfactorily in full-scale fire test scenarios as detailed in Section 4.41.2 within the limits stated in Table 4.41.1.

NOTE: There are no fire test requirements for K11.2 (K160) extended coverage hazard category 1 – 3 sprinklers.

Table 4.41.1. K14.0 (K200) Extended Coverage Hazard Category 1 – 3 Sprinkler Fire Test Limits

<i>Test</i>	<i>A</i>	<i>B</i>	<i>C</i>
Peak/Maximum One Minute Average Steel Temperature, °F(°C)	1200/1000 (649/538)	1200/1000 (649/538)	1200/1000 (649/538)
Aisle Jump/Fire Spread	See below*	See below*	See below*
Equivalent Maximum Number of Pallet Loads Consumed	4	4	4
Maximum Number of Sprinklers to Operate**	9	9	9

* Fire spread must be confined to the length of the main array. Fire spread to the ends of the main array or to a target array is not permitted.

** Sprinklers installed along the perimeter of the ceiling are not permitted to operate.

4.41.2 Tests/Verification

The tests detailed in this section shall be conducted in an indoor fire test facility with an adjustable ceiling positioned approximately 20 ft (6.1 m) from the floor. Sprinklers having a nominal temperature rating of 160°F (70°C) shall be installed at the spacing indicated in Table 4.41.2, on nominal 2 in. diameter Schedule 40 sprinkler pipes. The fire test array, which is further detailed in Figure D-27, shall be oriented such that the longitudinal flue space is parallel to the sprinkler branch lines and such that the sprinklers are centered about the geometric center of the double-row rack. Ignition shall be accomplished using a standard igniter and shall take place at the bottom of the first tier, at the intersection of the longitudinal and center transverse flue spaces. Temperatures shall be monitored by thermocouples located at the ceiling. Two-way, 42 in. x 42 in. x 5 in. (107 cm x 107 cm x 12.7 cm), slatted hardwood pallets placed in metal storage racks shall support the commodity.

Table 4.41.2. K14.0 (K200) Extended Coverage Hazard Category 1 – 3 Sprinkler Test Scenarios

<i>Test</i>	<i>A</i>	<i>B</i>	<i>C</i>
Storage Type	Double-Row Rack	Double-Row Rack	Double-Row Rack
Fuel (Standard Commodity)	Class 2	Class 2	Class 2
Main (Ignition) Array, number of pallets, (wide x long x high)	2 x 6 x 2	2 x 6 x 2	2 x 4 x 2
Target Arrays, number of pallets each, (wide x long x high)	1 x 4 x 2	1 x 4 x 2	1 x 4 x 2
Nominal Array Height ft (m)	9 (2.7)	9 (2.7)	9 (2.7)
Nominal Ceiling Height, ft (m)	20 (6.1)	20 (6.1)	20 (6.1)
Nominal Clearance-to-Ceiling ft (m)	11 (3.4)	11 (3.4)	11 (3.4)
Ignition	Below 1 sprinkler	Between 2 sprinklers	Below 1 sprinkler
Sprinkler Spacing ft x ft (m x m)	20 x 20 (6.1 x 6.1)	20 x 20 (6.1 x 6.1)	10 x 10 (3.0 x 3.0)
Deflector to Ceiling, in. (mm)	7 (178) upright 9 (230) pendent	7 (178) upright 9 (230) pendent	7 (178) upright 9 (230) pendent
Sprinkler Thermal Sensitivity	Quick Response	Quick Response	Quick Response
Water Pressure, psi (bar)	18 (1.2)	18 (1.2)	18 (1.2)
Test Duration (min)	30	30	30

4.42 Fire Tests - K14.0 (K200) Non-Storage Extended Coverage Horizontal Sidewall Sprinklers

4.42.1 Requirement

K14.0 (K200) non-storage extended coverage horizontal sidewall sprinklers shall perform satisfactorily in full-scale fire test scenarios as detailed in Section 4.42.2 within the limits stated in Tables 4.42.1a-c.

- A. Screening Tests - In order to define the ignition configuration which results in the most challenging fire scenario, three screening tests shall be conducted with different fuel array positions relative to the sprinkler locations. The sprinklers shall perform satisfactorily in the three test scenarios detailed in Table 4.42.2a within the limits stated in Table 4.42.1a. The scenario which results in the most challenging fire will then be used in the three application fire tests.

*Table 4.42.1a. K14.0 (K200) Extended Coverage
Horizontal Sidewall Sprinkler Screening Fire Test Limits*

<i>Test</i>	<i>A</i>	<i>B</i>	<i>C</i>
Peak/Maximum One Minute Average Steel Temperature °F (°C)	1200/1000 (649/538)	1200/1000 (649/538)	1200/1000 (649/538)
Damage	See below*	See below*	See below*
Maximum Number of Sprinklers to Operate**	6	6	6

* Fire spread must be confined to the length of the array. Fire spread to the ends of the array is not permitted.

** Sprinklers installed along the perimeter of the ceiling are not permitted to operate.

- B. Obstruction Tests - Two full scale fire tests shall be conducted with the sprinkler distribution pattern partially blocked by a mockup representing the permissible size and clearance limits for conduit obstructions. The sprinklers shall perform satisfactorily in the two test scenarios detailed in Table 4.42.2b within the limits stated in Table 4.42.1b.

*Table 4.42.1b. K14.0 (K200) Extended Coverage
Horizontal Sidewall Sprinkler Obstruction Fire Test Limits*

<i>Test</i>	<i>A</i>	<i>B</i>
Peak/Maximum One Minute Average Steel Temperature, °F (°C)	1200/1000 (649/538)	1200/1000 (649/538)
Damage	See below*	See below*
Maximum Number of Sprinklers to Operate**	4	4

* Fire spread must be confined to the length of the array. Fire spread to the ends of the array is not permitted.

** Sprinklers installed along the perimeter of the ceiling are not permitted to operate.

- C. Application Tests - The ignition configuration which results in the most challenging fire scenario, as defined by the results of the screening tests detailed in Table 4.42.2a, shall be used in three full-scale application fire tests. The sprinklers shall perform satisfactorily in the three test scenarios detailed in Table 4.42.2c within the limits stated in Table 4.42.1c.

*Table 4.42.1c. K14.0 (K200) Extended Coverage
Horizontal Sidewall Sprinkler Application Fire Test Limits*

<i>Test</i>	<i>A</i>	<i>B</i>	<i>C</i>
Peak/Maximum One Minute Average Steel Temperature °F (°C)	1200/1000 (649/538)	1200/1000 (649/538)	1200/1000 (649/538)
Damage	See below*	See below*	See below*
Maximum Number of Sprinklers to Operate**	8	8	8

¹ The orientation and ignition configuration of the commodity shall be determined by the screening test which results in the most challenging fire scenario (see Section 4.42.1A)

* Fire spread must be confined to the length of the array. Fire spread to the ends of the array is not permitted.

** Sprinklers installed along the perimeter of the ceiling are not permitted to operate.

4.42.2 Tests/Verification

The tests detailed in this section shall be conducted in a metal building test structure erected within an indoor fire test facility having a ceiling to floor distance of approximately 40 ft (12.2 m). The metal building shall measure 60 ft (18.3 m) long by 50 ft (15.2 m) wide by 32 ft (9.8 m) high at the roof apex. The wall height at the eaves shall measure 30 ft (9.1 m), resulting in a roof slope

of 1 in./12 in. (25 mm/305 mm), or 4.8 degrees. The roof shall be supported by three I-beam ceiling truss members, spaced 25 ft (7.6 m) apart, and supported at each end by an upright I-beam column. This arrangement shall create two 25 ft (7.6 m) wide interior bays with a 5 ft (1.52 m) overhang at each end. The ceiling trusses shall be 19.1 in. (.48 m) deep at the eaves and 43.1 in. (1.1 m) deep at the roof peak. The 50 ft (15.2 m) wide ends of the building shall remain open to the test facility.

Sprinklers having a nominal temperature rating of 160°F (70°C) shall be connected to nominal 2.5 in. sprinkler branch line pipes via 2.5 in. x 2.5 in. x 1 in. nominal threaded tees with a nominal 1 in. x ¾ in. reducing bushing, threadolet fittings with bushings, or a suitable alternative. The branch lines shall be installed on each side of the three ceiling support I-beams, supported by brackets attached to the top of the ceiling I-beams using special hangers intended for this purpose. The tees shall be located at distances of 7 ft (2.1 m), 21 ft (6.4 m), 29 ft (8.8 m) and 43 ft (13.1 m) from one of the 60 ft (18.3 m) long walls, resulting in a sprinkler spacing of 14 ft (4.3 m). The branch lines shall be hung such that the sprinkler deflectors are 14 in. (0.36 m) down from the underside of the roof. The deflector shelf of each sprinkler shall be aligned parallel to the floor of the test facility. The pipes shall be fed with water flowing from nominal 3 in. risers extending up each side of the I-beam columns to the eaves. The sprinkler installation positions and sprinkler system layout are further detailed in Figures D-28 and D-29.

Ignition of the commodity shall take place at the bottom of the first tier, at the intersection of the longitudinal and center transverse flue spaces. Two-way, 42 in. x 42 in. x 5 in., slatted hardwood pallets placed in metal storage racks shall support the commodity. Temperatures shall be monitored by thermocouples located at the ceiling. The fire test array is further detailed in Figure D-30.

- A. Screening Tests - Three screening tests shall be conducted with fuel array positions relative to the location of ceiling sprinklers as detailed in Table 4.42.2a. The scenario which results in the most challenging fire shall then be used in all subsequent application fire tests.

*Table 4.42.2a. K14.0 (K200) Extended Coverage
Horizontal Sidewall Sprinkler Test Scenarios – Screening Tests*

<i>Test</i>	<i>A</i>	<i>B</i>	<i>C</i>
Storage Type	Double-Row Rack	Double-Row Rack	Double-Row Rack
Fuel (Standard Commodity)	Class 2	Class 2	Class 2
Test Description/ Commodity Location	5 ft (1.5 m) from the wall perpendicular to beams (See Figure D-31)	Longitudinal flue parallel to and directly beneath the center beam. (See Figure D-31)	Center transverse flue parallel to and directly beneath center beam (See Figure D-31)
Test Array, number of pallets, (wide x long x high)	2 x 4 x 2	2 x 4 x 2	2 x 4 x 2
Nominal Array Height ft (m)	9 (2.7)	9 (2.7)	9 (2.7)
Nominal Ceiling Height, ft (m)	32 (9.7)	32 (9.7)	32 (9.7)
Nominal Clearance-to-Ceiling, ft (m)	23 (7.0)	23 (7.0)	23 (7.0)
Ignition	Between 2 sprinklers along adjacent wall	Centered between 2 sprinklers	Centered below 1 sprinkler
Sprinkler Spacing ft x ft (m x m)	14 x 25 (4.3 x 7.6)	14 x 25 (4.3 x 7.6)	14 x 25 (4.3 x 7.6)
Deflector to Ceiling, in. (mm) (see Fig D-29)	14 (356)	14 (356)	14 (356)
Sprinkler Thermal Sensitivity	Quick Response	Quick Response	Quick Response
Water Pressure, psi (bar)	7 (0.5)	7 (0.5)	7 (0.5)

<i>Test</i>	<i>A</i>	<i>B</i>	<i>C</i>
Test Duration (min)	30	30	30

- B. Obstruction Tests - Two obstruction tests shall be conducted with the sprinkler distribution pattern partially blocked by a mockup representing the maximum size and minimum clearance limits for conduit obstructions as detailed in Table 4.42.2b.

*Table 4.42.2b. K14.0 (K200) Extended Coverage
Horizontal Sidewall Sprinkler Test Scenarios – Obstruction Tests*

<i>Test</i>	<i>A</i>	<i>B</i>
Storage Type	Double-Row Rack	Double-Row Rack
Fuel (Standard Commodity)	Class 2	Class 2
Test Description	2 x 2 ft (0.61 x 0.61 m) obstruction	9 x 9 in. (0.23 x 0.23 m) obstruction
Test Array, number of pallets, (wide x long x high)	2 x 4 x 2	2 x 4 x 2
Commodity Location	Center of array 5 ft (1.5 m) from the wall perpendicular to beams (See Figure D-32)	Center of array 5 ft (1.5 m) from the wall perpendicular to beams (See Figure D-32)
Nominal Array Height ft (m)	9 (2.7)	9 (2.7)
Nominal Ceiling Height, ft (m)	32 (9.7)	32 (9.7)
Nominal Clearance-to-Ceiling, ft (m)	23 (7.0)	23 (7.0)
Obstruction Location	3 ft (0.91 m) below and 7.42 ft (2.26 m) out from sprinkler deflector (See Figure D-32)	12 in. (0.30 m) below and 34 in. (0.86 m) out from sprinkler deflector (See Figure D-32)
Ignition	Between 2 sprinklers along adjacent wall	Between 2 sprinklers along adjacent wall
Sprinkler Spacing ft x ft (m x m)	14 x 25 (4.3 x 7.6)	14 x 25 (4.3 x 7.6)
Deflector to Ceiling, in. (mm) (see Fig D-29)	14 (356)	14 (356)
Sprinkler Thermal Sensitivity	Quick Response	Quick Response
Water Pressure, psi (bar)	7 (0.5)	7 (0.5)
Test Duration (min)	30	30

- C. Application Tests - Three tests shall be conducted with a fuel array position relative to the location of ceiling sprinklers which resulted in the most challenging fire as determined by the screening tests. The tests shall be conducted as detailed in Table 4.42.2c.

Table 4.42.2c. K14.0 (K200) Extended Coverage
Horizontal Sidewall Sprinkler Test Scenarios – Application Tests

<i>Test</i>	<i>A</i>	<i>B</i>	<i>C</i>
Storage Type	Double-Row Rack	Double-Row Rack	Double-Row Rack
Fuel (Standard Commodity)	Cartoned Expanded Plastic	Cartoned Expanded Plastic	Uncartoned Expanded Plastic
Test-Array, number of pallets, (wide x long x high)	2 x 4 x 1	2 x 4 x 2	2 x 4 x 1
Nominal Array Height ft (m)	4 (1.2)	9 (2.7)	4 (1.2)
Nominal Ceiling Height, ft (m)	32 (9.7)	32 (9.7)	32 (9.7)
Nominal Clearance-to-Ceiling ft (m)	28 (8.5)	23 (7.0)	23 (7.0)
Ignition	Worst case ¹	Worst case ¹	Worst case ¹
Sprinkler Spacing ft x ft (m x m)	14 x 25 (4.3 x 7.6)	14 x 25 (4.3 x 7.6)	14 x 25 (4.3 x 7.6)
Deflector to Ceiling, in. (mm) (see Fig D-29)	14 (356)	14 (356)	14 (356)
Sprinkler Thermal Sensitivity	Quick Response	Quick Response	Quick Response
Water Pressure, psi (bar)	7 (0.5)	25 (1.7)	14 (1.0)
Test Duration (min)	30	30	30

¹ The orientation and ignition configuration of the commodity shall be determined by the screening test which results in the most challenging fire scenario (see Section 4.42.1A)

4.43 Fire Tests - K16.8 (K240) Upright Storage Sprinklers

4.43.1 Requirement

K16.8 (K240) upright storage sprinklers shall perform satisfactorily in full-scale fire test scenarios as detailed in Section 4.43.2 within the limits stated in Table 4.43.1.

Table 4.43.1. K16.8 (K240) Upright Storage Sprinkler Fire Test Limits

<i>Test</i>	<i>A</i>	<i>B</i>
Peak/Maximum One Minute Average Steel Temperature, °F (°C)	1200/1000 (649/538)	1200/1000 (649/538)
Aisle Jump/Fire Spread	See below*	See below*
Equivalent Maximum Number of Pallet Loads Consumed	10	10
Maximum Number of Sprinklers to Operate**	15	15

* Fire spread must be confined to the lengths of the main array and target array. Fire spread to the ends of either array or to the back of the target array is not permitted.

** Sprinklers installed along the perimeter of the ceiling are not permitted to operate.

4.43.2 Tests/Verification

The tests detailed in this section shall be conducted in an indoor fire test facility with an adjustable ceiling. Sprinklers having a nominal temperature rating of 160°F (70°C) shall be installed at the spacing indicated in Table 4.43.2, on nominal 2 in. diameter Schedule 40 sprinkler pipes. The pipes shall be oriented perpendicular to the length of the test array and positioned such that the sprinklers are centered about the geometric center of the ceiling. Ignition shall be accomplished using a standard igniter and shall take place at the bottom of the first tier at the geometric center of the double row rack. Temperatures shall be monitored by thermocouples located at the ceiling. Two-way, 42 in. x 42 in. x 5 in. (107 cm x 107 cm x 12.7 cm), slatted hardwood pallets placed in metal storage racks support the commodity.

Table 4.43.2. K16.8 (K240) Upright Storage Sprinkler Test Scenarios

Test	A	B
Storage Type	Double-Row Rack	Double-Row Rack
Fuel (Standard Commodity)	Cartoned Unexpanded Plastic	Cartoned Unexpanded Plastic
Test Array	see Figure D-33	see Figure D-34
Nominal Array Height ft (m)	9 (2.7)	14 (4.3)
Nominal Clearance-to-Ceiling, ft (m)	21 (6.4)	11 (3.4)
Nominal Ceiling Height, ft (m)	30 (9.1)	25 (7.6)
Ignition	Below 1 sprinkler	Below 1 sprinkler
Sprinkler Spacing ft x ft (m x m)	10 x 10 (3.0 x 3.0)	10 x 10 (3.0 x 3.0)
Deflector to Ceiling, in. (mm)	7 (178)	7 (178)
Sprinkler Thermal Sensitivity	Standard Response	Standard Response
Water Pressure, psi (bar)	7 (0.5)	13 (0.9)
Test Duration (min)	30	30

4.44 Fire Tests - K19.6 (K280) Pendent Storage Sprinklers

4.44.1 Requirement

K19.6 (K280) pendent storage sprinklers with a nominal K-factor of 19.6 gal/min/(psi)^{1/2} shall perform satisfactorily in full-scale fire test scenarios as detailed in Section 4.44.2 within the limits stated in Table 4.44.1.

Table 4.44.1. K19.6 (K280) Pendent Storage Sprinkler Fire Test Limits

Test	A	B	C
Peak/Maximum One Minute Average Steel Temperature; °F (°C)	1200/1000 (649/538)	1200/1000 (649/538)	1200/1000 (649/538)
Aisle Jump/Fire Spread	See below*	See below*	See below*
Maximum Number of Sprinklers to Operate**	10	8	8

* Fire spread must be confined to the lengths of the main array and target array. Fire spread to the ends of either array or to the back of the target array is not permitted.

** Sprinklers installed along the perimeter of the ceiling are not permitted to operate.

Table 4.44.1. K19.6 (K280) Pendent Storage Sprinkler Fire Test Limits (Continued)

Test	D	E	F
Peak/Maximum One Minute Average Steel Temperature; °F (°C)	1200/1000 (649/538)	1200/1000 (649/538)	1200/1000 (649/538)
Aisle Jump/Fire Spread	See below*	See below*	See below*
Maximum Number of Sprinklers to Operate**	13	11	11

* Fire spread must be confined to the lengths of the main array and target array. Fire spread to the ends of either array or to the back of the target array is not permitted.

** Sprinklers installed along the perimeter of the ceiling are not permitted to operate.

4.44.2 Tests/Verification

The tests detailed in Table 4.44.2 shall be conducted in an indoor fire test facility with an adjustable ceiling measuring 80 ft x 80 ft (24.4 m x 24.4 m). Sprinklers having a nominal temperature rating of 160°F (70°C) shall be installed on nominal 2.5 in. diameter Schedule 40 sprinkler pipes at the spacing indicated. For tests having a sprinkler spacing of 8 x 10 ft (2.4 x 3.0 m), the pipes are spaced 10 ft (3.0 m) apart. For tests having a sprinkler spacing of 8 x 12 ft (2.4 x 3.7 m), the pipes are spaced 8 ft (2.4 m) apart.

The storage array shall consist of a main double row rack, 8 pallet loads long, and two single row target racks, 4 pallet loads long, one on either side of the main rack, separated by an aisle space 4 ft (1.2 m) wide. The main rack shall be configured with rack uprights in the center transverse flue space and shall be oriented such that the transverse flues are parallel to the sprinkler branch line pipes. The main rack and both target racks shall be filled with the specified commodity, as shown in the appropriate figure. Commodity moisture content shall be 6 percent \pm 2 percent (dry basis).

Ignition shall take place in the center transverse flue space at the bottom of the first tier of the main rack, offset 2 ft (0.6 m) from the geometric center of the rack. Ignition locations for tests C and F shall be selected based on the lowest Actual Delivered Density (ADD) results at the corresponding conditions. Temperatures shall be monitored by thermocouples located at the ceiling.

Temperatures shall be monitored by thermocouples located at the ceiling. Two-way, 42 in. x 42 in. x 5 in. (107 cm x 107 cm x 12.7 cm), slatted hardwood pallets placed in metal storage racks support the commodity.

Table 4.44.2. K19.6 (K280) Pendent Storage Sprinkler Fire Test Scenarios

Test	A	B	C
Storage Type	Double Row Rack (See Figure D-35)	Double-Row Rack (See Figure D-35)	Double-Row Rack (See Figure D-36)
Fuel (Standard Commodity)	Cartoned Unexpanded Plastic	Cartoned Unexpanded Plastic	Cartoned Unexpanded Plastic
Nominal Array Height ft (m)	19 (5.8)	19 (5.8)	24 (7.3)
Nominal Ceiling Height, ft (m)	30 (9.1)	30 (9.1)	30 (9.1)
Nominal Clearance-to-Ceiling, ft (m)	11 (3.4)	11 (3.4)	6 (1.8)
Ignition	Below 1 sprinkler	Below 1 sprinkler	Between 2 or 4 sprinklers*
Sprinkler Spacing ft x ft (m x m)	8 x 10 (2.4 x 3.0)	10 x 10 (3.0 x 3.0)	8 x 12 (2.4 x 3.7)
Deflector to Ceiling, in. (mm)	12 (305)	12 (305)	12 (305)
Water Pressure, psi (bar)	16 (1.1)	16 (1.1)	16 (1.1)
Test Duration (min)	30	30	30

* The ignition location for test C is based on worst-case scenario determined by ADD/PWD testing.

NOTE: if test A is deemed successful, and results in only one sprinkler operating, test B may be omitted at the discretion of the certification agency.

Table 4.44.2. K19.6 (K280) Pendent Storage Sprinkler Fire Test Scenarios (Continued)

<i>Test</i>	<i>D</i>	<i>E</i>	<i>F</i>
Storage Type	Double Row Rack (See Figure D-37)	Double-Row Rack (See Figure D-37)	Double-Row Rack (See Figure D-38)
Fuel (Standard Commodity)	Cartoned Unexpanded Plastic	Cartoned Unexpanded Plastic	Cartoned Unexpanded Plastic
Nominal Array Height ft (m)	24 (7.3)	24 (7.3)	29 (8.8)
Nominal Ceiling Height, ft (m)	35 (10.7)	35 (10.7)	35 (10.7)
Nominal Clearance-to-Ceiling, ft (m)	11 (3.4)	11 (3.4)	6 (1.8)
Ignition	Below 1 sprinkler	Below 1 sprinkler	Between 2 or 4 sprinklers*
Sprinkler Spacing ft x ft (m x m)	8 x 10 (2.4 x 3.0)	10 x 10 (3.0 x 3.0)	8 x 12 (2.4 x 3.7)
Deflector to Ceiling, in. (mm)	12 (305)	12 (305)	12 (305)
Water Pressure, psi (bar)	25 (1.7)	25 (1.7)	25 (1.7)
Test Duration (min)	30	30	30

* The ignition location for test F is based on worst-case scenario determined by ADD/PWD testing.

NOTE: if test D is deemed successful, and results in only one sprinkler operating, test E may be omitted at the discretion of the certification agency.

4.45 Fire Tests - (K25.2 (K360) Upright and Pendent Storage Sprinklers)

4.45.1 Requirement

K25.2 (K360) upright and pendent storage sprinklers shall perform satisfactorily in full-scale fire test scenarios as detailed in Section 4.45.2 within the limits stated in Table 4.45.1.

Table 4.45.1. K25.2 (K360) Upright and Pendent Storage Sprinkler Fire Test Limits

<i>Test</i>	<i>A</i>	<i>B</i>	<i>C</i>
Peak/Maximum One Minute Average Steel Temperature °F (°C)	1200/1000 (649/538)	1200/1000 (649/538)	1200/1000 (649/538)
Aisle Jump/Fire Spread	See below*	See below*	See below*
Maximum Number of Sprinklers to Operate**	8	8	8

* Fire spread must not extend beyond the last transverse flue to either side of ignition and must not burn through the back side of either target array.

** Sprinklers installed along the perimeter of the ceiling are not permitted to operate.

4.45.2 Tests/Verification

The tests detailed in Table 4.45.2 shall be conducted in an indoor fire test facility with an adjustable ceiling measuring 80 ft x 80 ft (24.4 m x 24.4 m). Sprinklers having a nominal temperature rating of 160°F (70°C) shall be installed on nominal 2.5 in. diameter Schedule 40 sprinkler pipes at the spacing indicated.

The storage array shall consist of a main double row rack, 8 pallet loads long, and two single row target racks, 4 pallet loads long, one on either side of the main rack, separated by an aisle space 4 ft (1.2 m) wide. The main rack shall be configured with rack uprights in the center transverse flue

space and shall be oriented such that the transverse flues are parallel to the sprinkler branch line pipes. The main rack and both target racks shall be filled with the specified commodity, as shown in the appropriate figure. Commodity moisture content shall be 6 percent \pm 2 percent (dry basis).

Ignition shall take place in the center transverse flue space at the bottom of the first tier of the main rack, offset 2 ft (0.6 m) from the geometric center of the rack. Ignition location for test A shall be selected based on the lowest Actual Delivered Density (ADD) results at the corresponding conditions. Temperatures shall be monitored by thermocouples located at the ceiling.

If test B is successfully completed with only a single sprinkler operating, test C may be omitted at the sole discretion of the certification agency.

Table 4.45.2. K25.2 (K360) Upright and Pendent Storage Sprinkler Test Scenarios

<i>Test</i>	<i>A</i>	<i>B</i>	<i>C</i>
Storage Type	Double-Row Rack (Figure D-39)	Double-Row Rack (Figure D-40)	Double-Row Rack (Figure D-40)
Fuel (Standard Commodity)	Cartoned Unexpanded Plastic	Cartoned Unexpanded Plastic	Cartoned Unexpanded Plastic
Nominal Array Height ft (m)	24 (7.3)	19 (5.8)	19 (5.8)
Nominal Ceiling Height, ft (m)	30 (9.1)	30 (9.1)	30 (9.1)
Nominal Clearance-to-ceiling ft (m)	6 (1.8)	11 (3.4)	11 (3.4)
Ignition	Between 2 or 4 sprinklers*	Below 1 sprinkler	Below 1 sprinkler
Sprinkler Spacing** ft x ft (m x m)	8 x 12 (2.4 x 3.7)	8 x 8 (2.4 x 2.4)	10 x 10 (3.0 x 3.0)
Heat Responsive Element to Ceiling, in. (mm)	12 (305)	12 (305)	12 (305)
Water Pressure for Pendent, psi (bar)	15 (1.0)	15 (1.0)	15 (1.0)
Water Pressure for Upright, psi (bar)	20 (1.4)	20 (1.4)	20 (1.4)
Test Duration (min)	30	30	30

* The ignition location for test A is based on worst-case scenario determined by ADD/PWD testing.

** Sprinkler spacing = Distance between adjacent pipes x Distance between sprinklers on the same pipe.

4.46 Fire Tests - K25.2EC (K360EC) Upright and Pendent Storage Sprinklers

4.46.1 Requirement

K25.2EC (K360EC) extended coverage upright and pendent storage sprinklers shall perform satisfactorily in full-scale fire test scenarios as detailed in Section 4.46.2 within the limits stated in Table 4.46.1.

Table 4.46.1. K25.2EC (K360EC) Upright and Pendent Storage Sprinkler Fire Test Limits

<i>Test</i>	<i>A</i>	<i>B</i>	<i>C</i>	<i>D</i>
Peak/Maximum One Minute Average Steel Temperature °F (°C)	1200/1000 (649/538)	1200/1000 (649/538)	1200/1000 (649/538)	1200/1000 (649/538)
Aisle Jump/Fire Spread	See below*	See below*	See below*	See below*
Maximum Number of Sprinklers to Operate**	8	8	8	13

* Fire spread must not extend beyond the last transverse flue to either side of ignition and must not burn through the back side of either target array.

** Sprinklers installed along the perimeter of the ceiling are not permitted to operate.

4.46.2 Tests/Verification

The tests detailed in Table 4.46.2 shall be conducted in an indoor fire test facility with an adjustable ceiling measuring 80 ft x 80 ft (24.4 m x 24.4 m). Sprinklers having a nominal temperature rating of 160°F (70°C) shall be installed on nominal 2.5 in. diameter Schedule 40 sprinkler pipes at the spacing indicated.

The storage array shall consist of a main double row rack, 8 pallet loads long, and two single row target racks, 4 pallet loads long, one on either side of the main rack, separated by an aisle space 4 ft (1.2 m) wide. The main rack shall be configured with rack uprights in the center transverse flue space and shall be oriented such that the transverse flues are parallel to the sprinkler branch line pipes. The main rack and both target racks shall be filled with the specified commodity, as shown in the appropriate figure. Commodity moisture content shall be 6 percent \pm 2 percent (dry basis).

Ignition shall take place in the center transverse flue space at the bottom of the first tier of the main rack, offset 2 ft (0.6 m) from the geometric center of the rack. Ignition locations for tests A and D shall be selected based on the lowest Actual Delivered Density (ADD) results at the corresponding conditions. Temperatures shall be monitored by thermocouples located at the ceiling.

If test B is successfully completed with only a single sprinkler operating, test C may be omitted at the sole discretion of the certification agency.

Table 4.46.2 K25.2EC (K360EC) Upright and Pendent Storage Sprinkler Test Scenarios

Test	A	B	C	D***
Storage Type	Double-Row Rack (Figure D-41)	Double-Row Rack (Figure D-42)	Double-Row Rack (Figure D-42)	Double-Row Rack (Figure D-43)
Fuel (Standard Commodity)	Cartoned Unexpanded Plastic	Cartoned Unexpanded Plastic	Cartoned Unexpanded Plastic	Cartoned Unexpanded Plastic
Nominal Array Height ft (m)	24 (7.3)	19 (5.8)	19 (5.8)	19 (5.8)
Nominal Ceiling Height, ft (m)	30 (9.1)	30 (9.1)	30 (9.1)	25 (7.6)
Nominal Clearance-to-ceiling ft (m)	6 (1.8)	11 (3.4)	11 (3.4)	6 (1.8)
Ignition	Between 2 or 4 sprinklers*	Below 1 sprinkler	Below 1 sprinkler	Between 2 or 4 sprinklers*
Sprinkler Spacing** ft x ft (m x m)	14 x 14 (4.3 x 4.3)	10 x 10 (3.0 x 3.0)	14 x 14 (4.3 x 4.3)	14 x 14 (4.3 x 4.3)
Heat Responsive Element to Ceiling, in. (mm)	12 (305)	12 (305)	12 (305)	12 (305)
Water Pressure, psi (bar)	30 (2.0)	30 (2.0)	30 (2.0)	30 (2.0)
Test Duration (min)	30	30	30	30

* The ignition locations for tests A and D are based on worst-case scenario determined by ADD/PWD testing.

** Sprinkler spacing = Distance between adjacent pipes x Distance between sprinklers on the same pipe.

*** Test D includes a 15 in. deep x 25 ft long sheet metal obstruction located at the ceiling, its length oriented parallel to the main array, offset 4 ft (1.2 m) from the center of the array into the aisle adjacent to ignition.

5 MANUFACTURER'S REQUIREMENTS

5.1 Demonstrated Quality Control Program

5.1.1 A quality assurance program is required to assure that subsequent products produced by the manufacturer shall present the same quality and reliability as the specific products examined. Design quality, conformance to design, and performance are the areas of primary concern.

- Design quality is determined during the examination and tests and may be documented in the certification report.
- Continued conformance to this standard is verified by the certifier's surveillance program.
- Quality of performance is determined by field performance and by periodic re-examination and testing.

5.1.2 The manufacturer shall demonstrate a quality assurance program which specifies controls for at least the following areas:

- existence of corporate quality assurance guidelines;
- incoming quality assurance, including testing;
- in process quality assurance, including testing;
- final inspection and tests;
- equipment calibration;
- drawing and change control;
- packaging and shipping; and
- handling and disposition of non-conforming materials.

5.1.3 Documentation/Manual

There should be an authoritative collection of procedures/policies. It should provide an accurate description of the quality management system while serving as a permanent reference for implementation and maintenance of that system. The system should require that sufficient records are maintained to demonstrate achievement of the required quality and verify operation of the quality system.

5.1.4 Records

To assure adequate traceability of materials and products, the manufacturer shall maintain a record of all quality assurance tests performed, for a minimum period of two years from the date of manufacture.

5.1.5 Drawing and Change Control

- The manufacturer shall establish a system of product configuration control that shall allow no unauthorized changes to the product. Changes to critical documents, identified in the certification report, may be required to be reported to, and authorized by the certification agency prior to implementation for production.
- Records of all revisions to all certified products shall be maintained.

5.2 Surveillance Audit

- 5.2.1 An audit of the manufacturing facility may be part of the certification agencies surveillance requirements to verify implementation of the quality assurance program. Its purpose is to determine that the manufacturer's equipment, procedures, and quality program are maintained to ensure a uniform product consistent with that which was tested and certified.
- 5.2.2 Certified products or services shall be produced or provided at, or provided from, location(s) disclosed as part of the certification examination. Manufacture of products bearing a certification mark is not permitted at any other location prior to disclosure to the certification agency.

5.3 Product Modifications

- 5.3.1 The manufacturer shall notify the certification agency of changes in product construction, components, raw materials, physical characteristics, coatings, component formulation or quality assurance procedures prior to implementation.

5.4 Manufacturing and Production Tests

For each of the following requirements, records of testing shall be maintained for a minimum of two years.

5.4.1 *Test Requirement No. 1 - Hydrostatic Pressure*

The manufacturer shall pressure test 100 percent of production to a hydrostatic pressure, or equivalent, of 500 psi (34.5 bar) for 2 seconds.

5.4.2 *Test Requirement No. 2 - Operating Temperature*

The manufacturer shall perform periodic tests for operating temperature of glass bulbs and fusible elements.

5.4.3 *Test Requirement No. 3 - Element Strength*

The manufacturer shall perform periodic tests for operating element strength.

5.4.4 *Test Requirement No. 4 - Glass Bulb Integrity*

The manufacturer shall test 100 percent of the glass bulb sprinklers to ensure that the glass bulb has not been damaged during assembly.

6 BIBLIOGRAPHY

ISO/IEC 17025, *General Requirements for the Competence of Testing and Calibration Laboratories*.

APPENDIX A:

This appendix is left intentionally blank.

APPENDIX B: TOLERANCES

Unless otherwise stated, the following tolerances shall apply:

Angle:	$\pm 2^\circ$
Frequency (Hz):	± 5 percent of value
Length:	± 2 percent of value
Volume:	± 5 percent of value
Rotation:	± 1 RPM
Pressure:	± 3 percent of value
Temperature:	± 5 percent of value
Time:	+ 5/-0 seconds
	+ 0.1/-0 minutes
	+ 0.1/-0 hours
	+ 0.25/-0 days

Unless stated otherwise, all tests should be carried out at a room (ambient) temperature of $68 \pm 12^\circ\text{F}$ ($20 \pm 6.7^\circ\text{C}$).

APPENDIX C: TOLERANCE LIMIT CALCULATIONS

Utilizing the data obtained as described in Sections 4.2.2 and 4.3.2B, the mean and standard deviation for the assembly load and the bulb strength shall be calculated using the following equation:

$$\sigma_{n-1} = \left(\frac{\sum_{i=1}^n (x_i - \bar{x})^2}{n-1} \right)^{1/2}$$

Where:

- σ_{n-1} = standard deviation
- \bar{x} = sample mean
- x_i = individual values of each sample tested
- n = number of samples tested

Based upon the number of sprinklers or bulbs tested (n), a value, γ , shall be selected from Table D1 where the degree of confidence is 0.99 and the proportion of samples is 0.99.

*Table D1. γ Factors for One-Sided Tolerance Limits For Normal Distributions
(99 Percent of Samples)*

<i>n</i>	<i>γ</i>	<i>n</i>	<i>γ</i>	<i>n</i>	<i>γ</i>
10	5.075	17	4.038	24	3.638
11	4.828	18	3.961	25	3.601
12	4.633	19	3.893	30	3.446
13	4.472	20	3.832	35	3.334
14	4.336	21	3.776	40	3.250
15	4.224	22	3.727	45	3.181
16	4.124	23	3.680	50	3.124

Tolerance limits shall then be calculated as follows:

$$LTL = \bar{x}_B - \gamma_B \sigma_{(n-1)B}$$

$$UTL = \bar{x}_S + \gamma_S \sigma_{(n-1)S}$$

Where:

- LTL* = lower tolerance limits for bulb strength
- UTL* = upper tolerance limit for sprinkler assembly load
- \bar{x}_B = mean bulb strength
- γ_B = bulb strength factor (γ) from Table D1
- $\sigma_{(n-1)B}$ = *sample* unbiased standard deviation for the bulb
- \bar{x}_S = mean *assembly* load
- $\sigma_{(n-1)S}$ = *sample* unbiased standard deviation for the assembly load
- γ_S = assembly load factor (γ) from Table D1

Compliance with the requirement shall be confirmed if $LTL > 2 \times UTL$.

Outliers may be discarded from the sample base utilizing appropriate statistical techniques at the discretion of the certification agency.

APPENDIX D: FIGURES

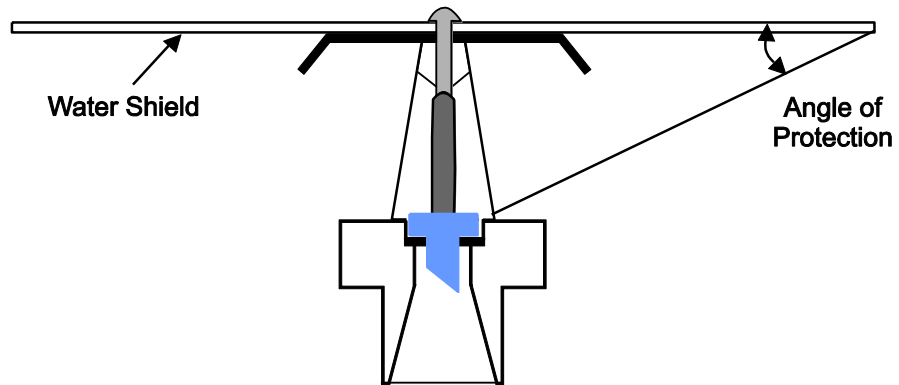
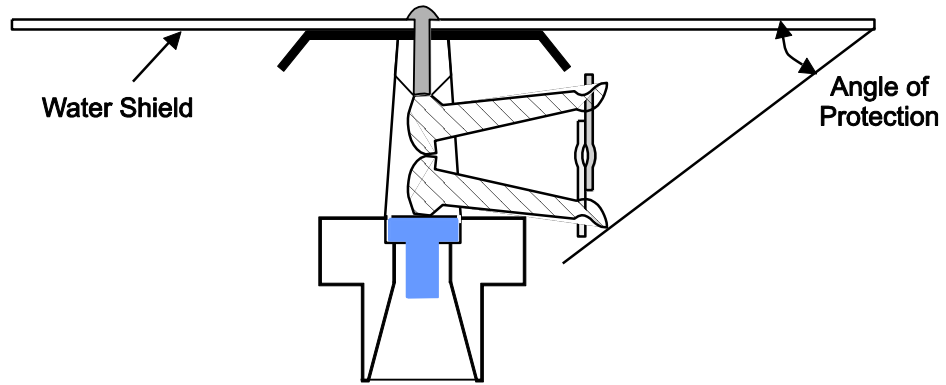

D-1: Impingement (Angle of Protection) – In-Rack Sprinkler

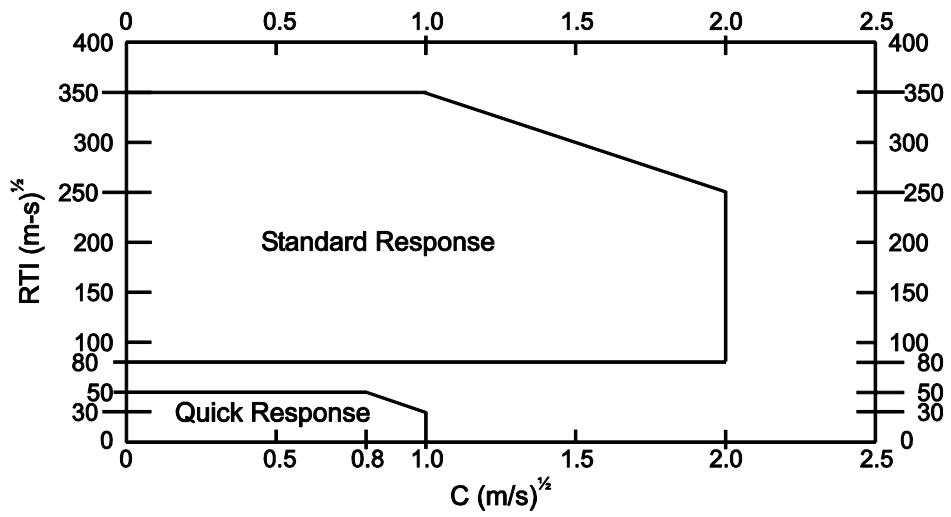
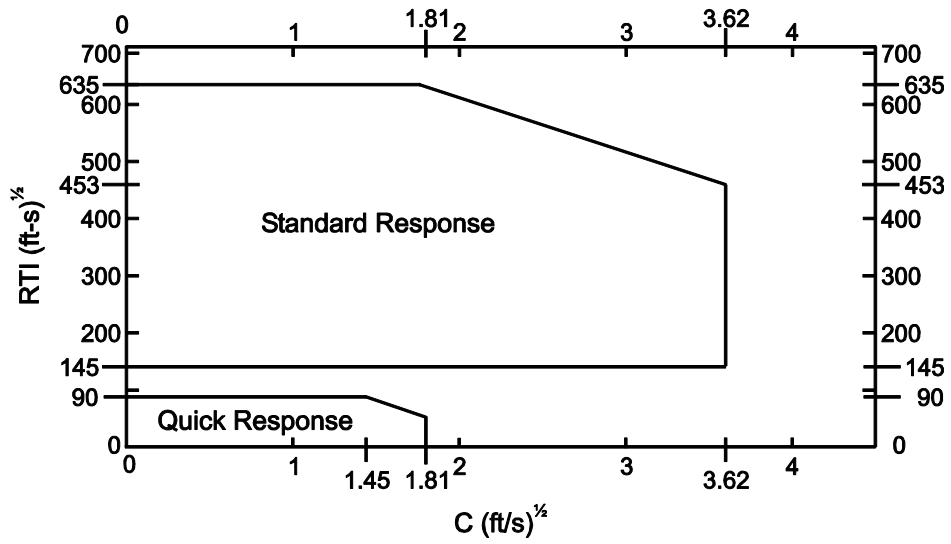

D-2: RTI and C-Factor Limits for Best Case Orientation

For Designs with Line Contact:

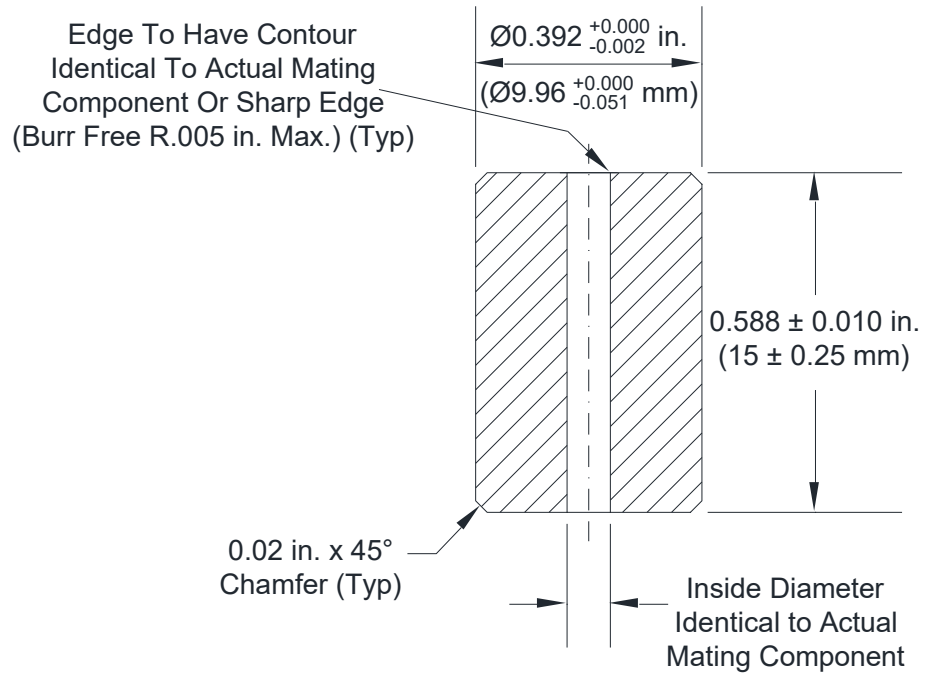

Or: For Designs with Surface Contact:

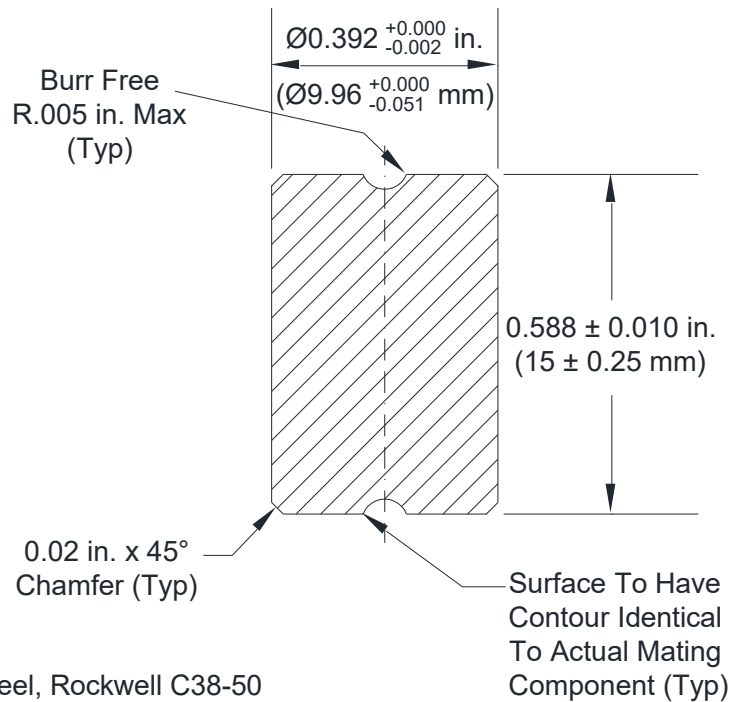

REQUIRED:

- * Material - Hardened Steel, Rockwell C38-50
- * Marking - Manufacturer, Bulb Size, Seat Diameter

D-3: Bulb Crush Inserts for Strength of Element Test

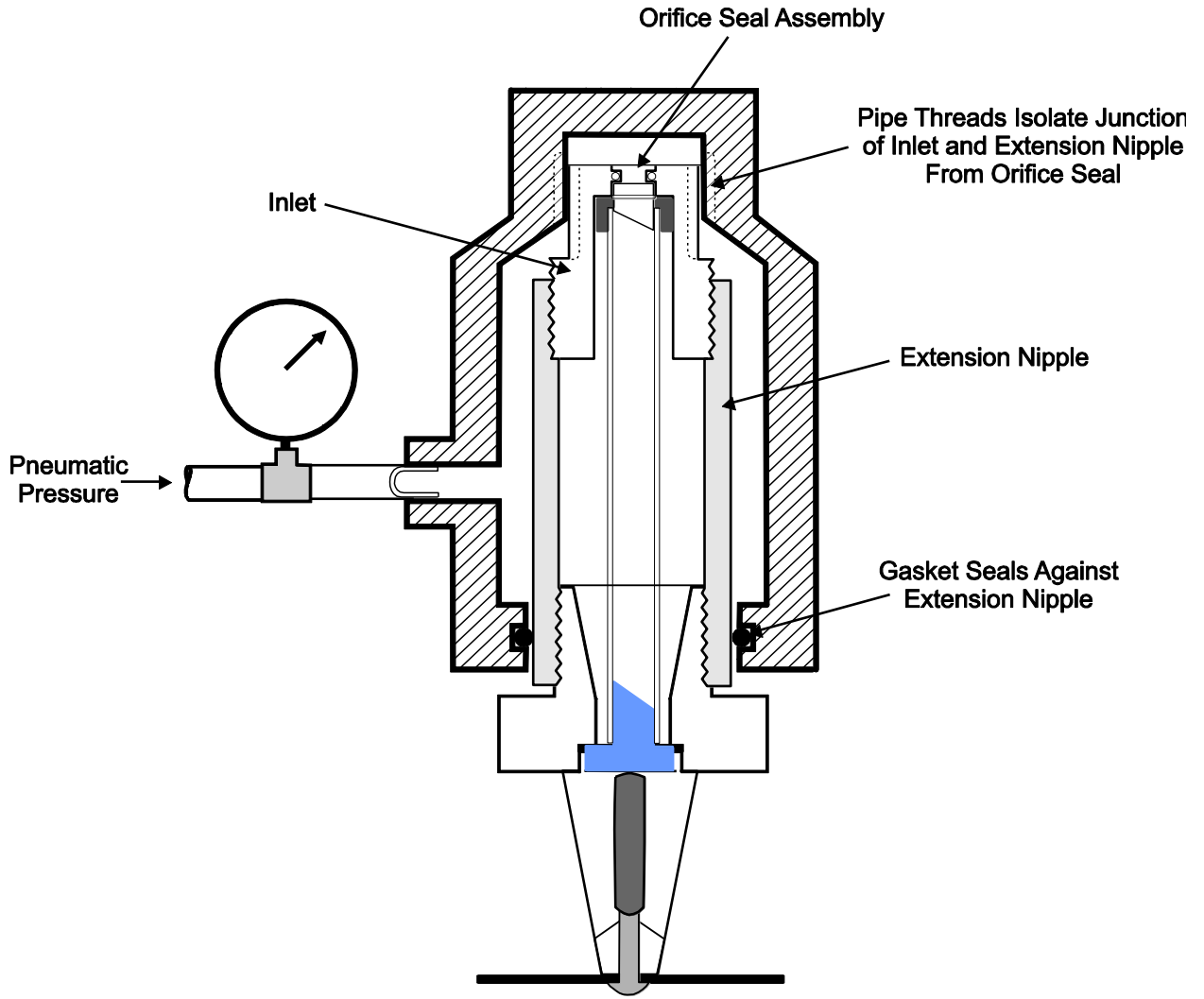

D-4: Pneumatic Leakage - Dry Sprinkler Inlet Test (Dry Sprinklers Only)

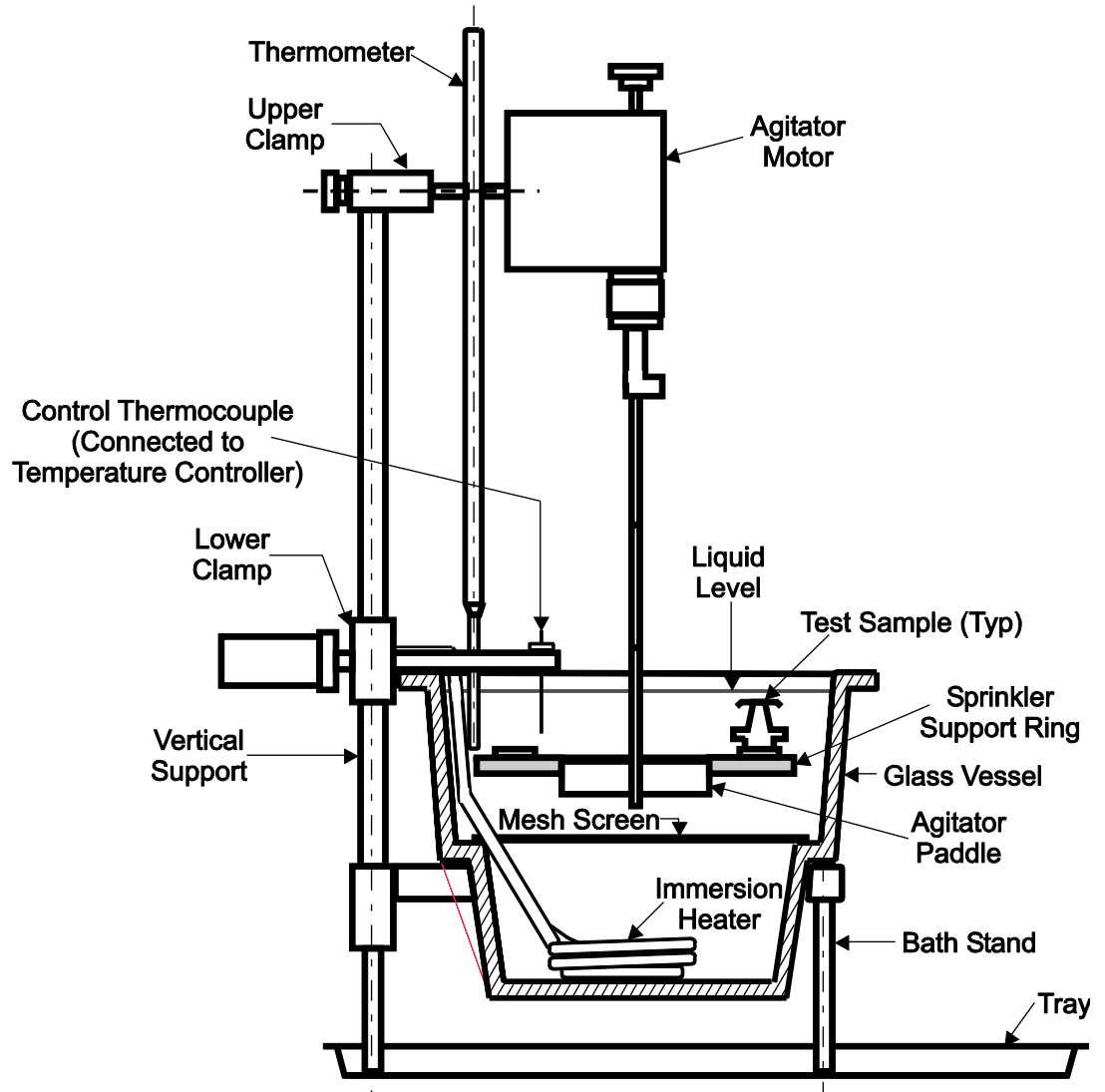

D-5: Operating Temperature (Liquid Bath) Typical Test Setup

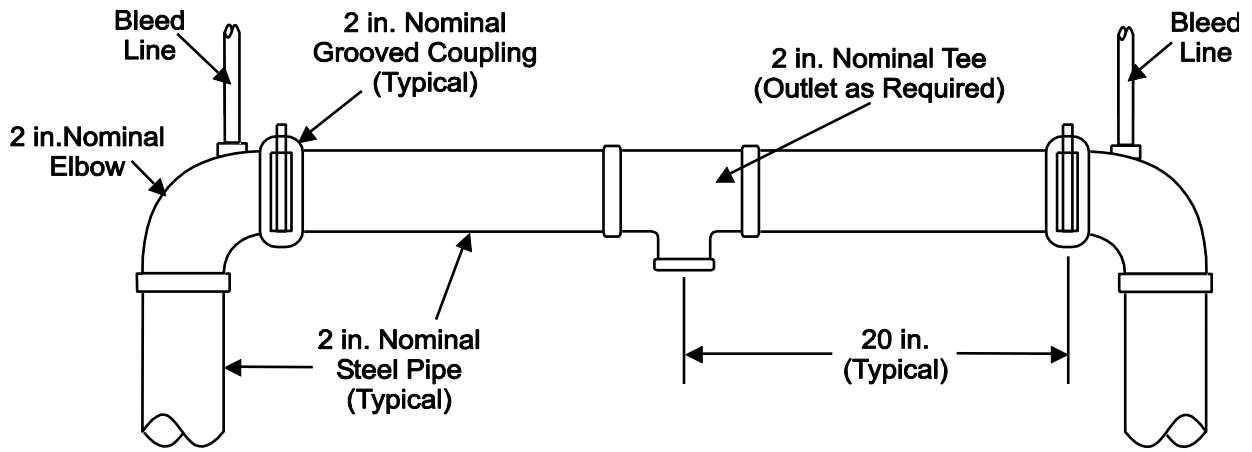

Test Apparatus for Double-Fed Flow

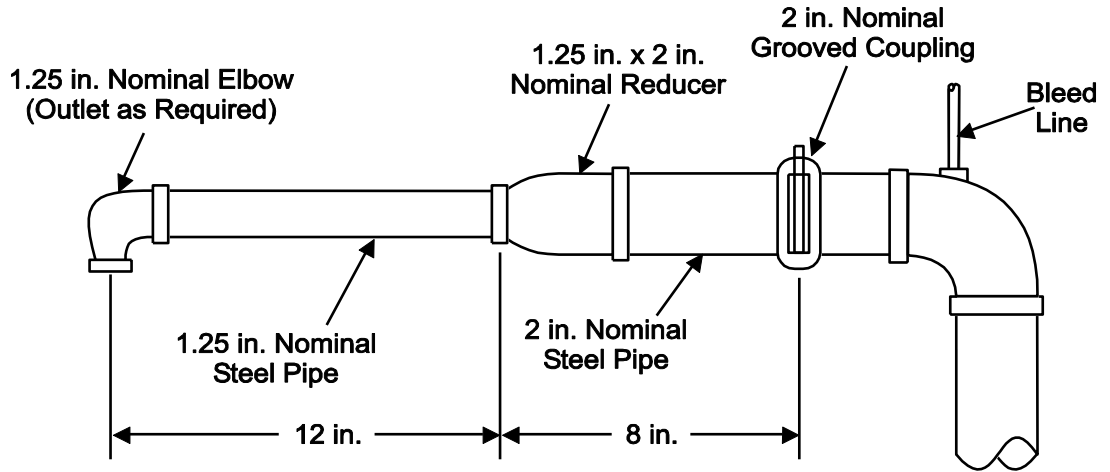

Test Apparatus for Single-Fed Flow

Note: All dimensions are nominal size.

D-6: Test Apparatus for Hang-up of Operating Parts Test

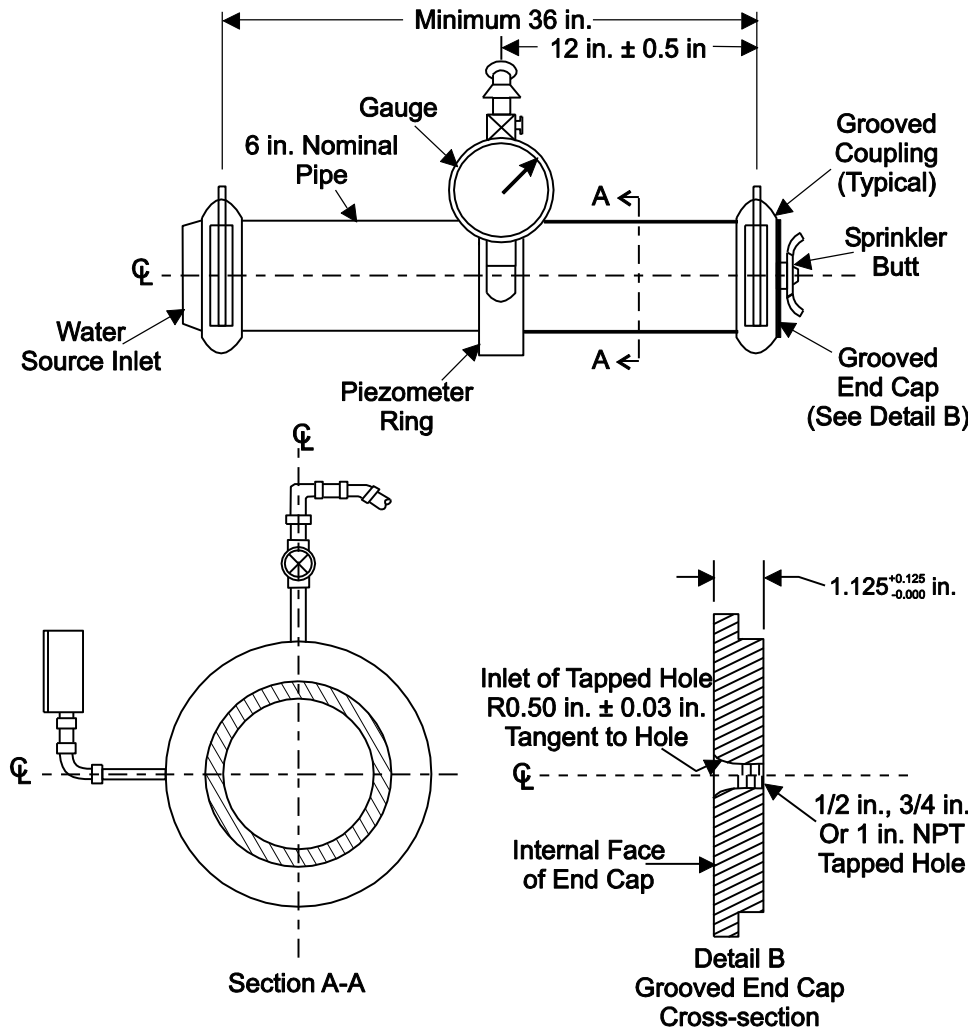

Note: All dimensions are nominal size unless otherwise indicated.
 Radius on Inlet may be truncated on internal face.

D-7: Test Apparatus for Measuring Nominal Discharge Coefficient (K-Factor)

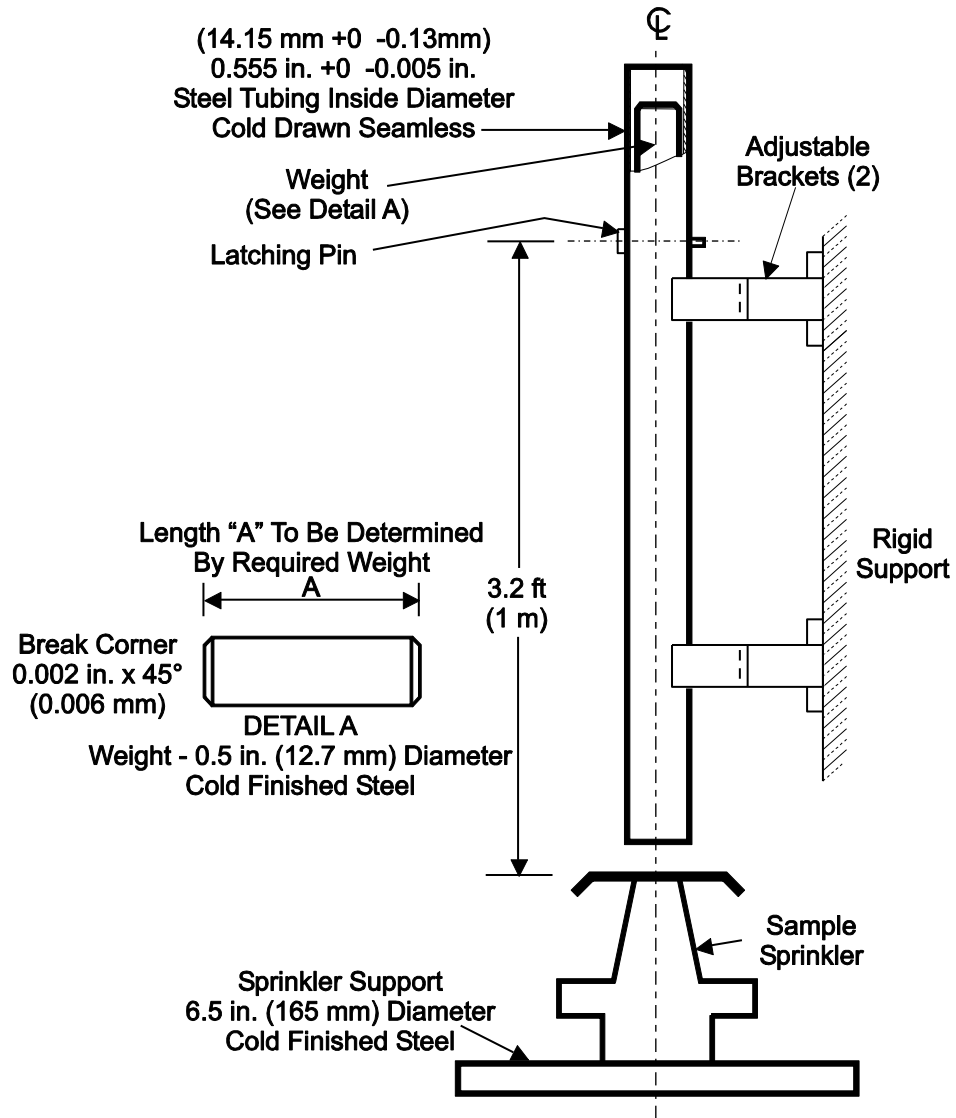

D-8: Rough use and Abuse (Drop Impact) Test Apparatus

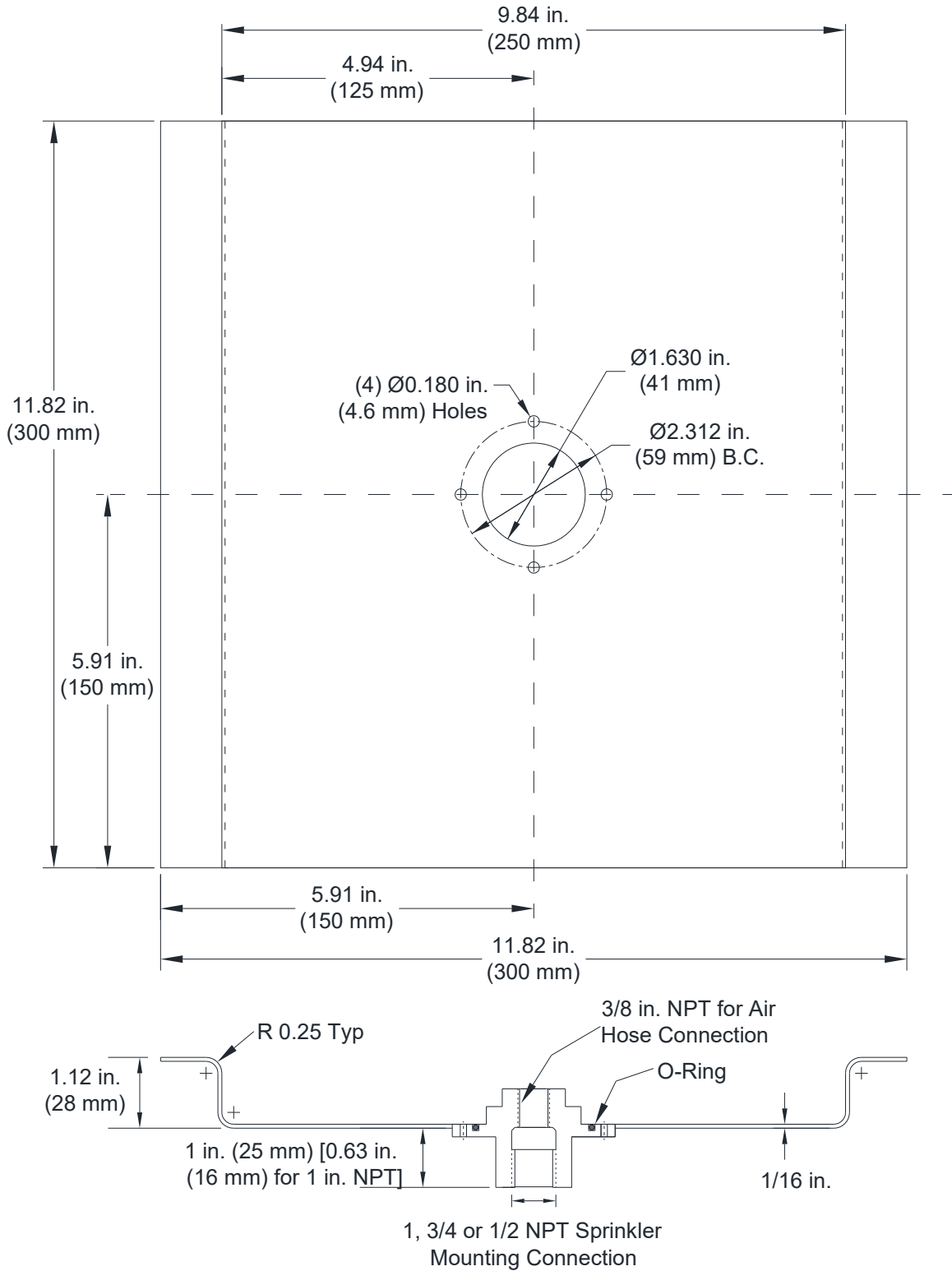

D-9: Plunge Tunnel Test Plate (For Sensitivity - RTI Test)

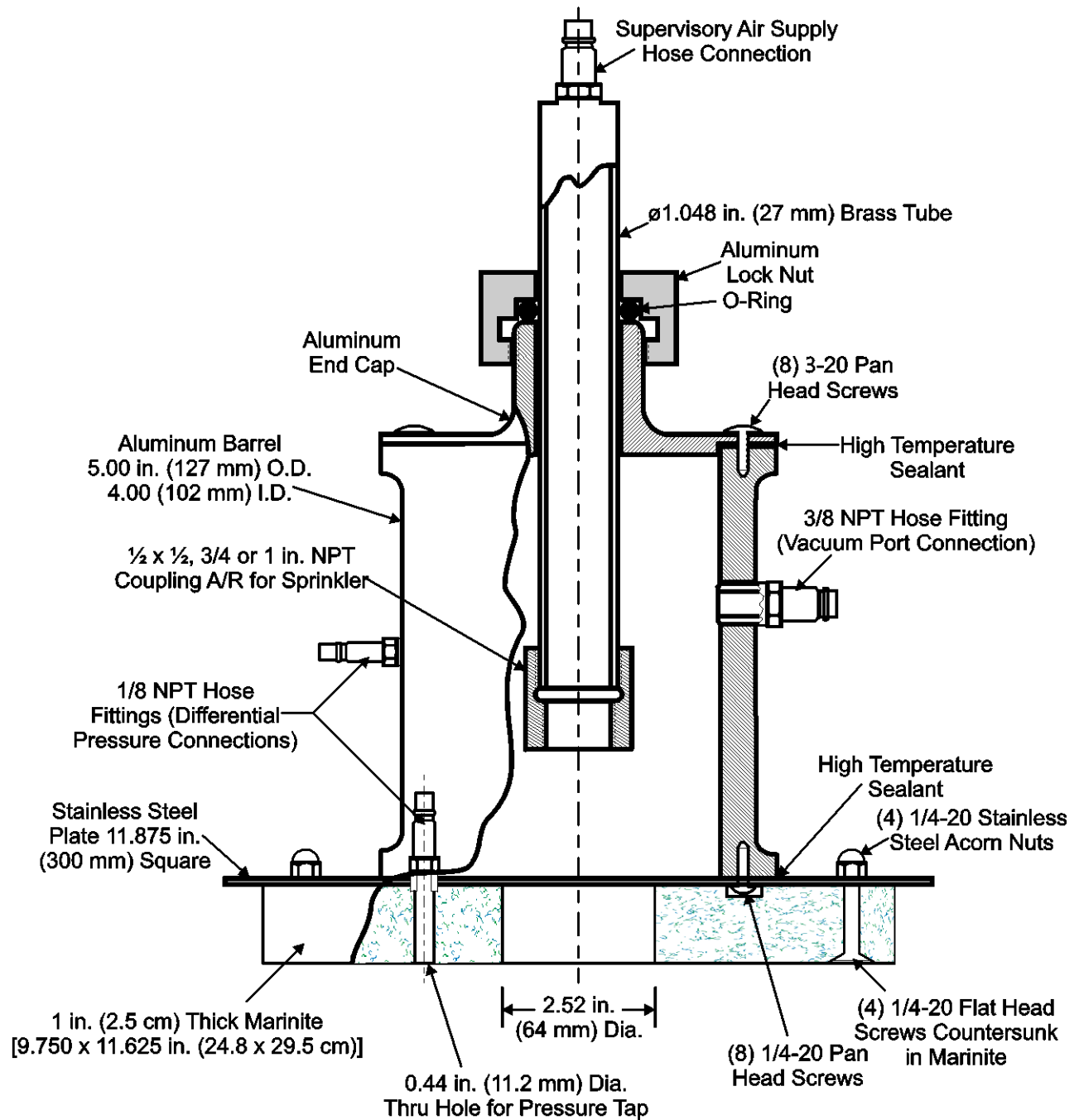

D-10: Modified Plunge Tunnel Test Plate (For Sensitivity Test - Recessed, Flush and Concealed Sprinklers)

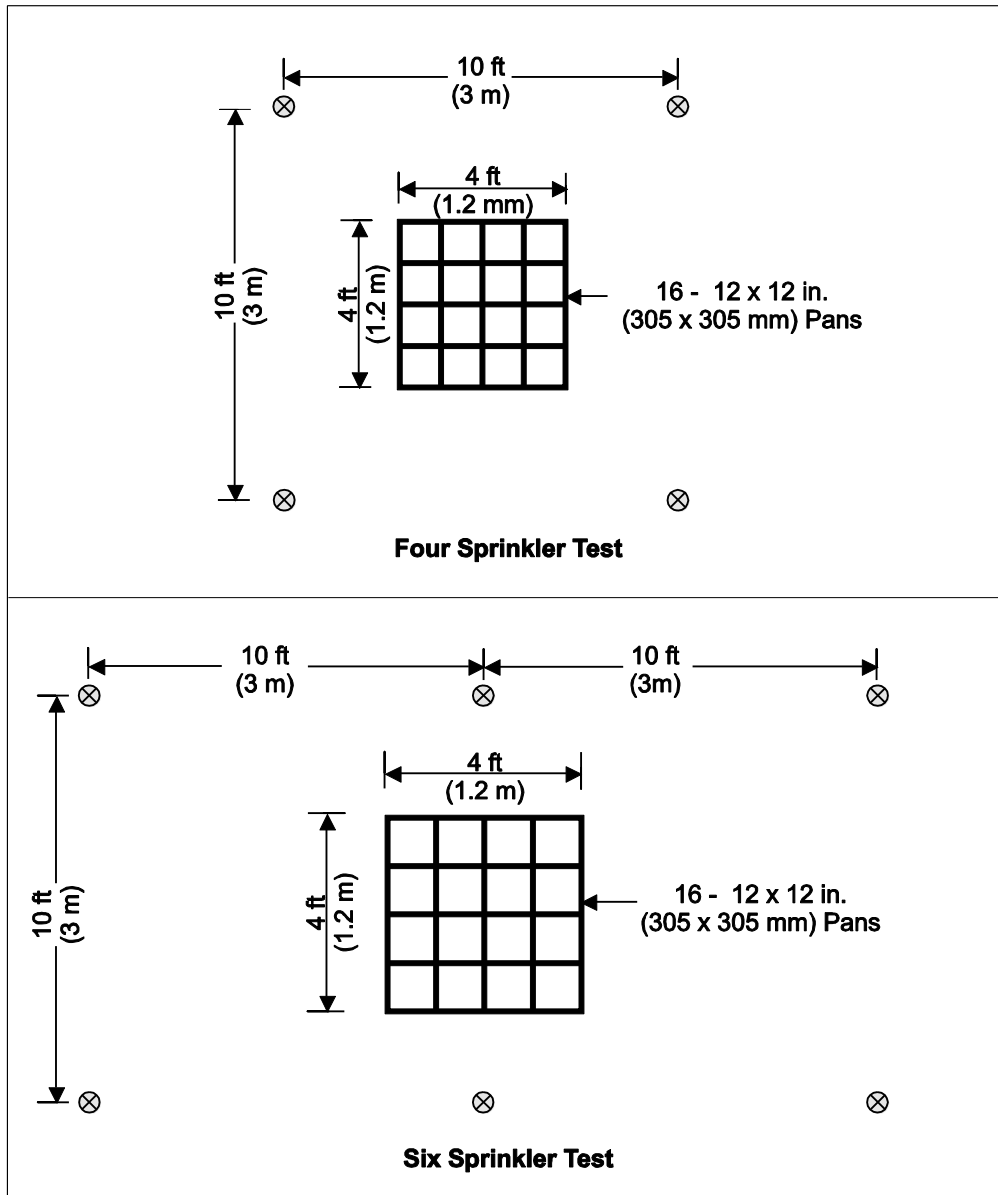

Note: ⊗ Designates Sprinkler location

D-11: Standard Coverage Sprinkler Distribution - Upright and Pendent Sprinkler Plan Configuration

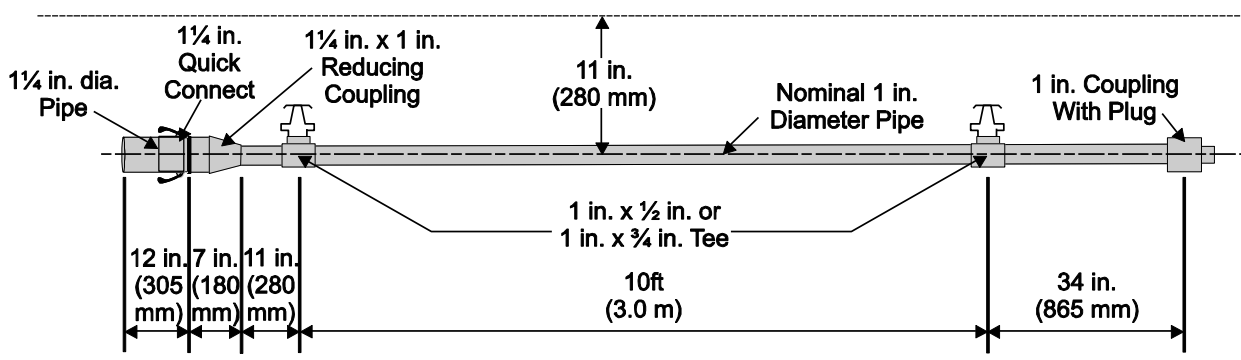
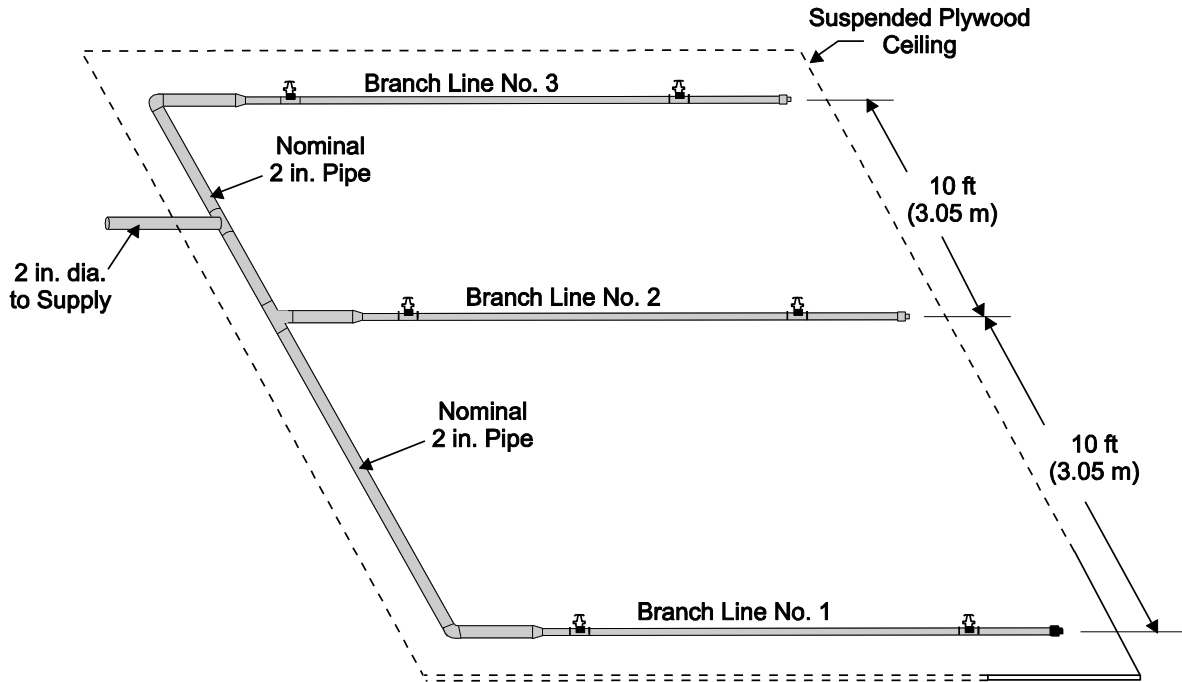

Typical Branch Line

NOTE: All dimensions are nominal sizes.
All pipe length dimensions are center to center (c-c).

D-12: Standard Coverage Sprinkler Distribution - Piping Configuration for Upright Sprinklers

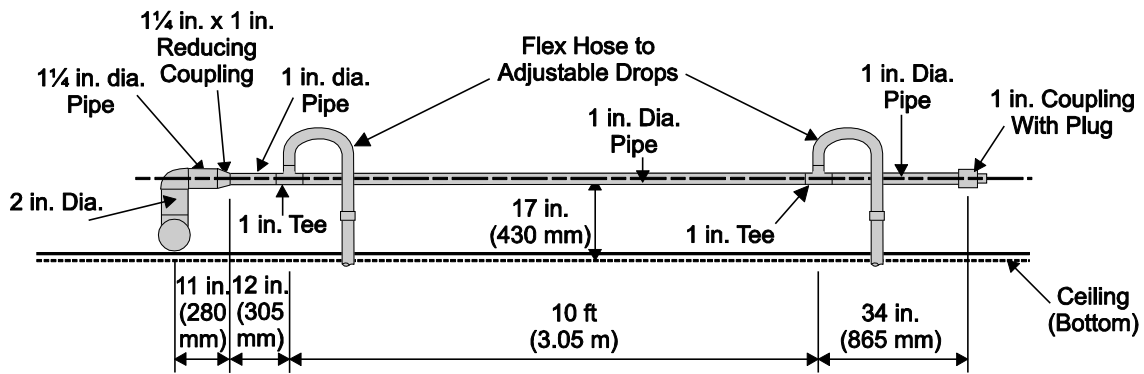
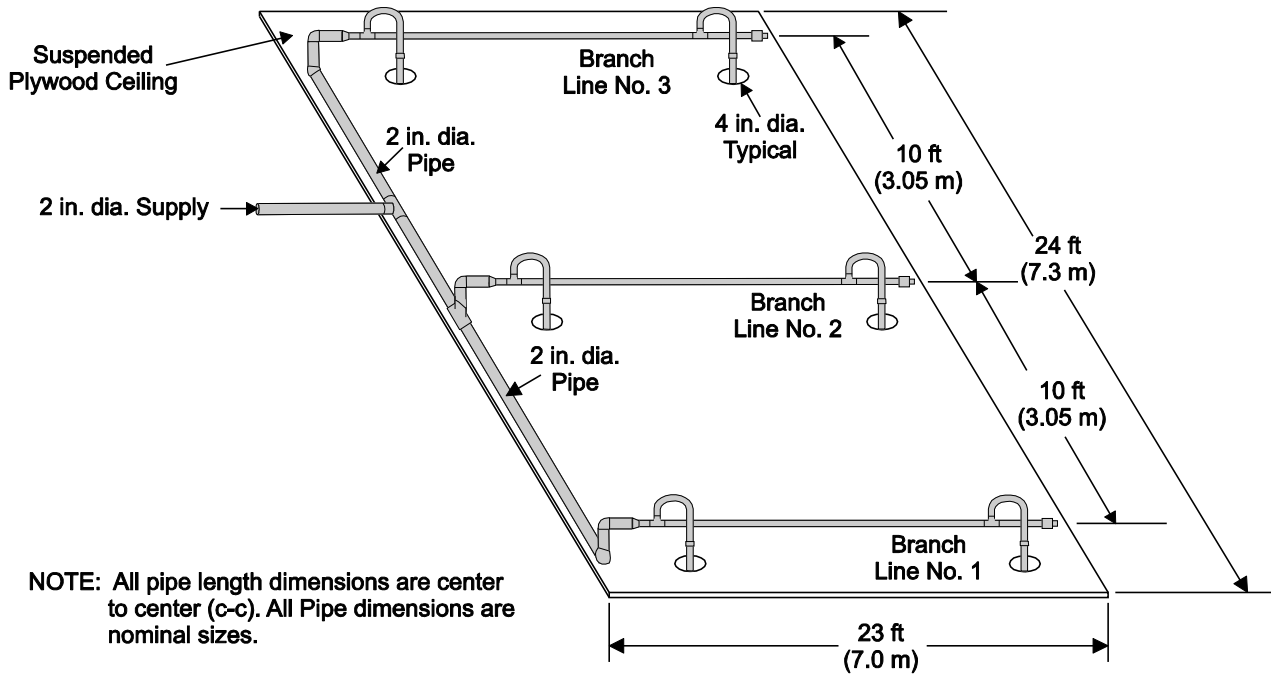

Typical Branch Line

D-13: Standard Coverage Sprinkler Distribution - Piping Configuration for Pendent Sprinklers

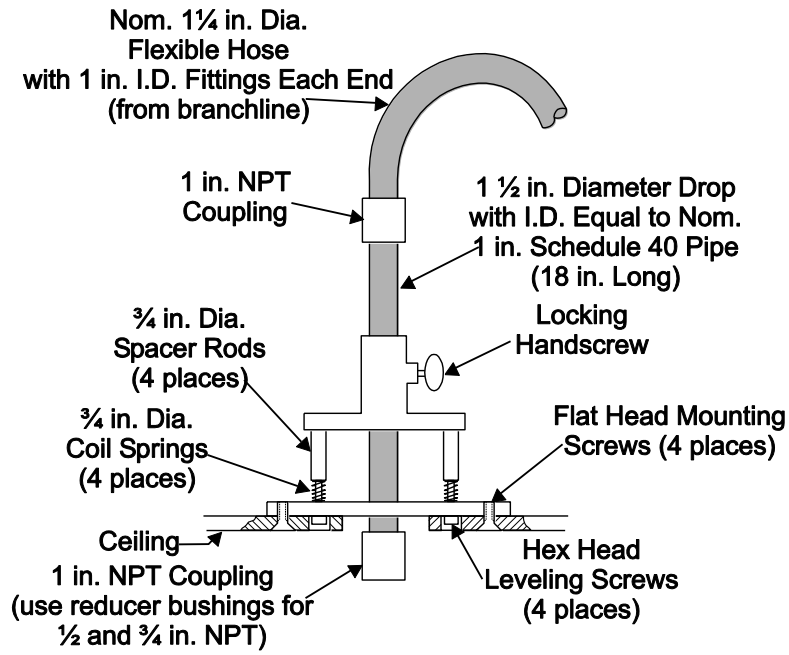

D-14: Standard Coverage Sprinkler Distribution - Adjustable Drop Detail for Pendent Sprinklers

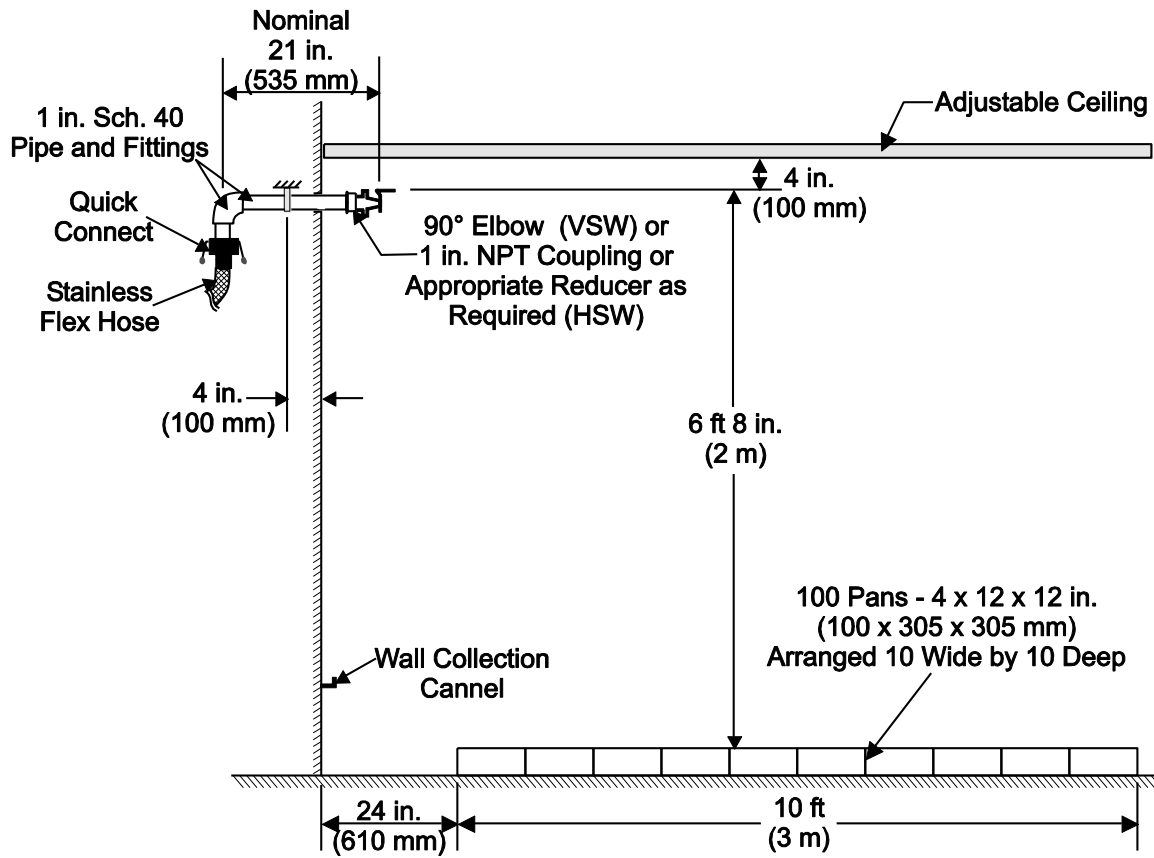

Note: All 1 in. nominal size pipe unless otherwise noted

D-15: Standard Coverage Sprinkler Distribution – Test Setup for Sidewall Sprinklers

Sprinkler Location Detail

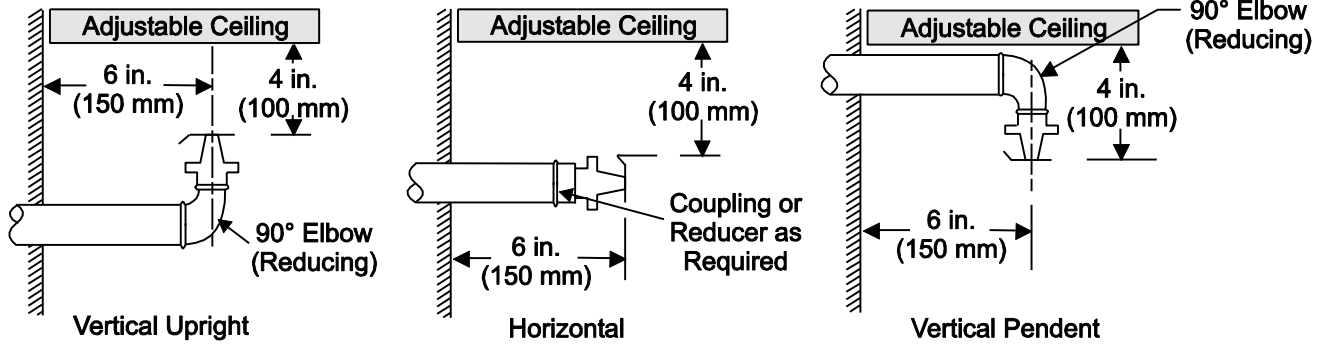

Note: All Piping 1 Inch Schedule 40

Wall Collection Channel Detail

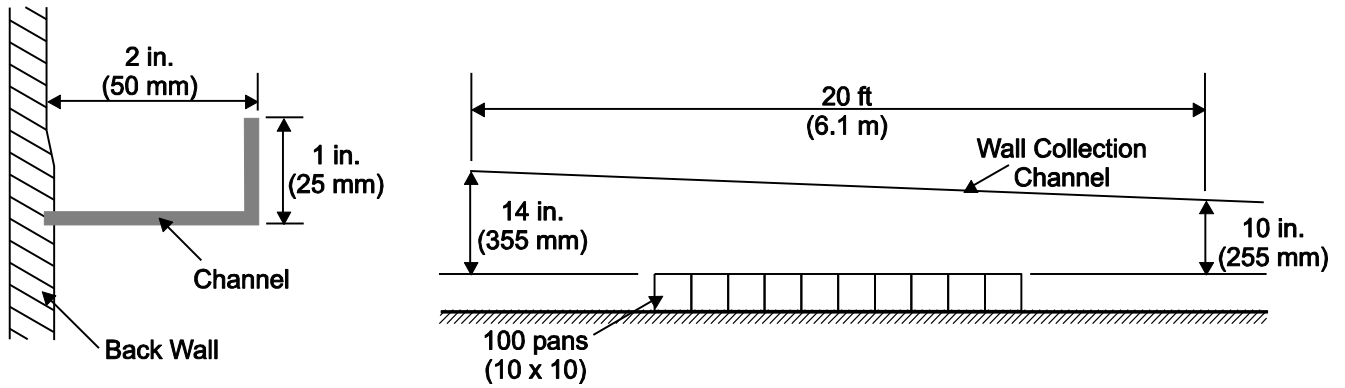

D-16: Standard Coverage Sprinkler Distribution – Test Setup for Sidewall Sprinklers (Detail)

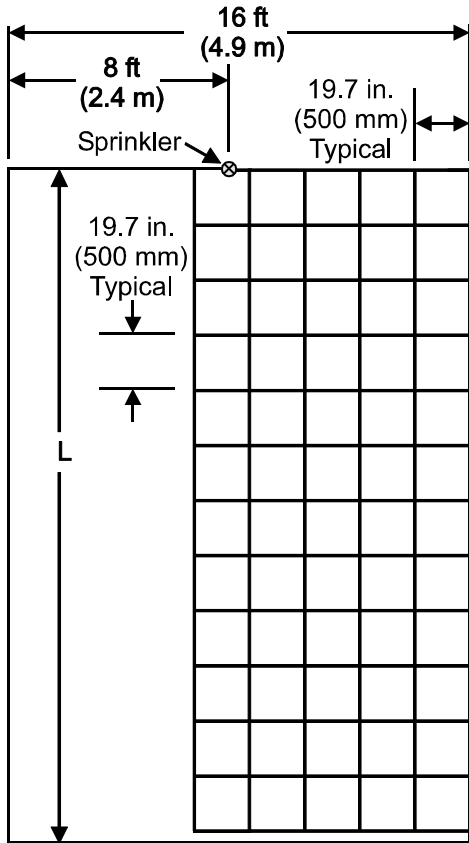

Plan View
EC Sidewall

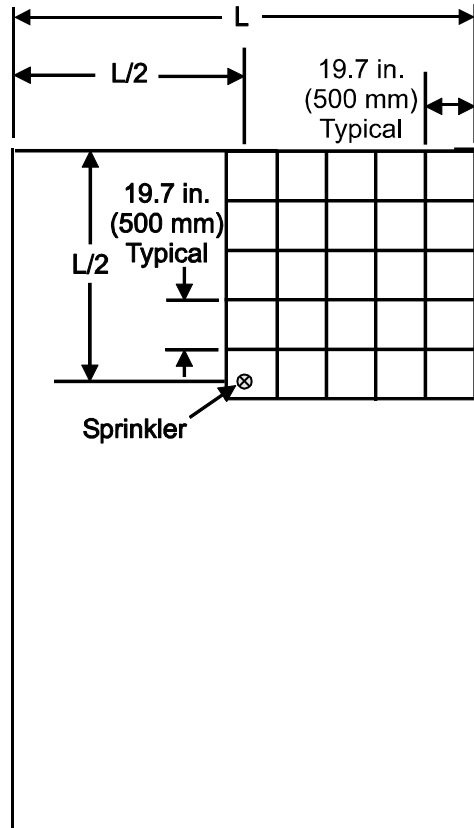

Plan View
EC Upright and Pendant

Where: L is the characteristic room length

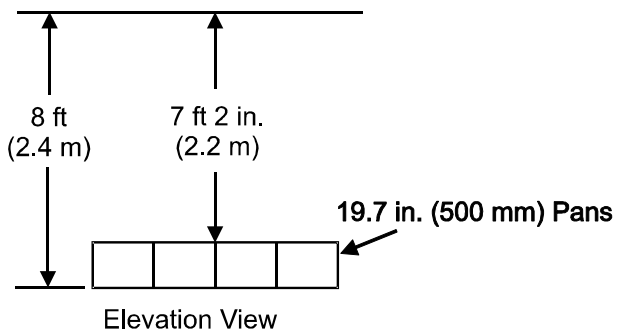

D-17: Distribution Test Setup for Extended Coverage Hazard Category 1 (HC-1) Sprinklers

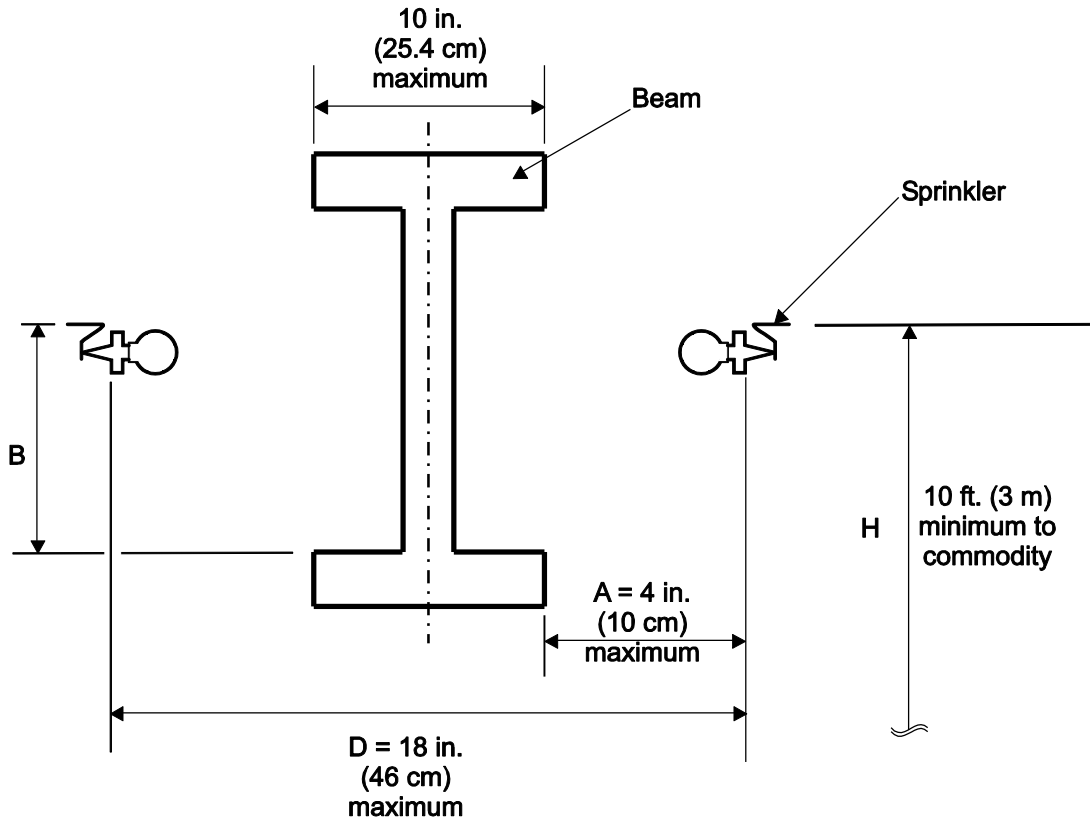

D-18: K14.0 (K200) Non-Storage Extended Coverage Horizontal Sidewall Sprinkler Location for Distribution

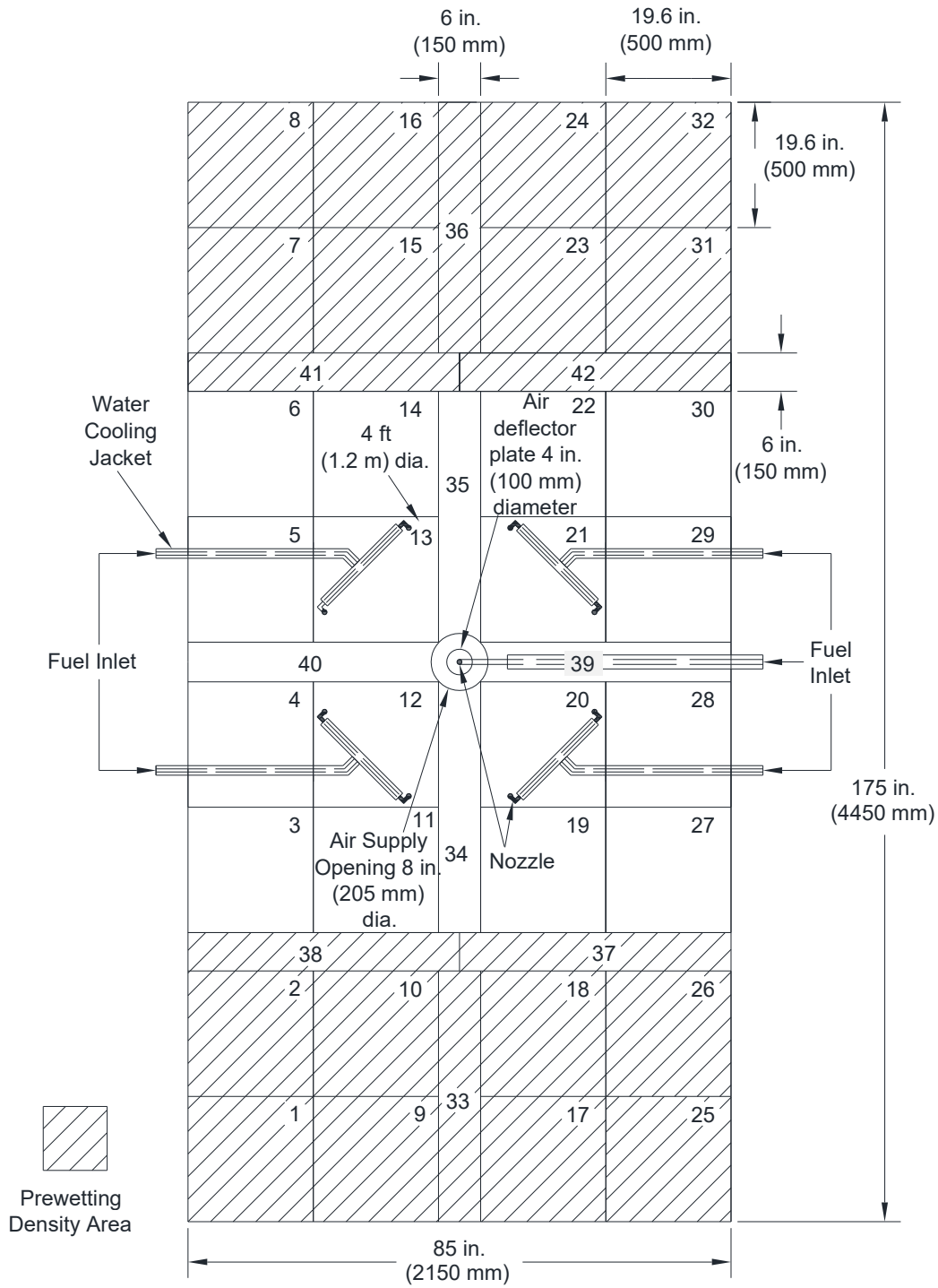

D-19: Actual Delivered Density (ADD) Apparatus – Plan View

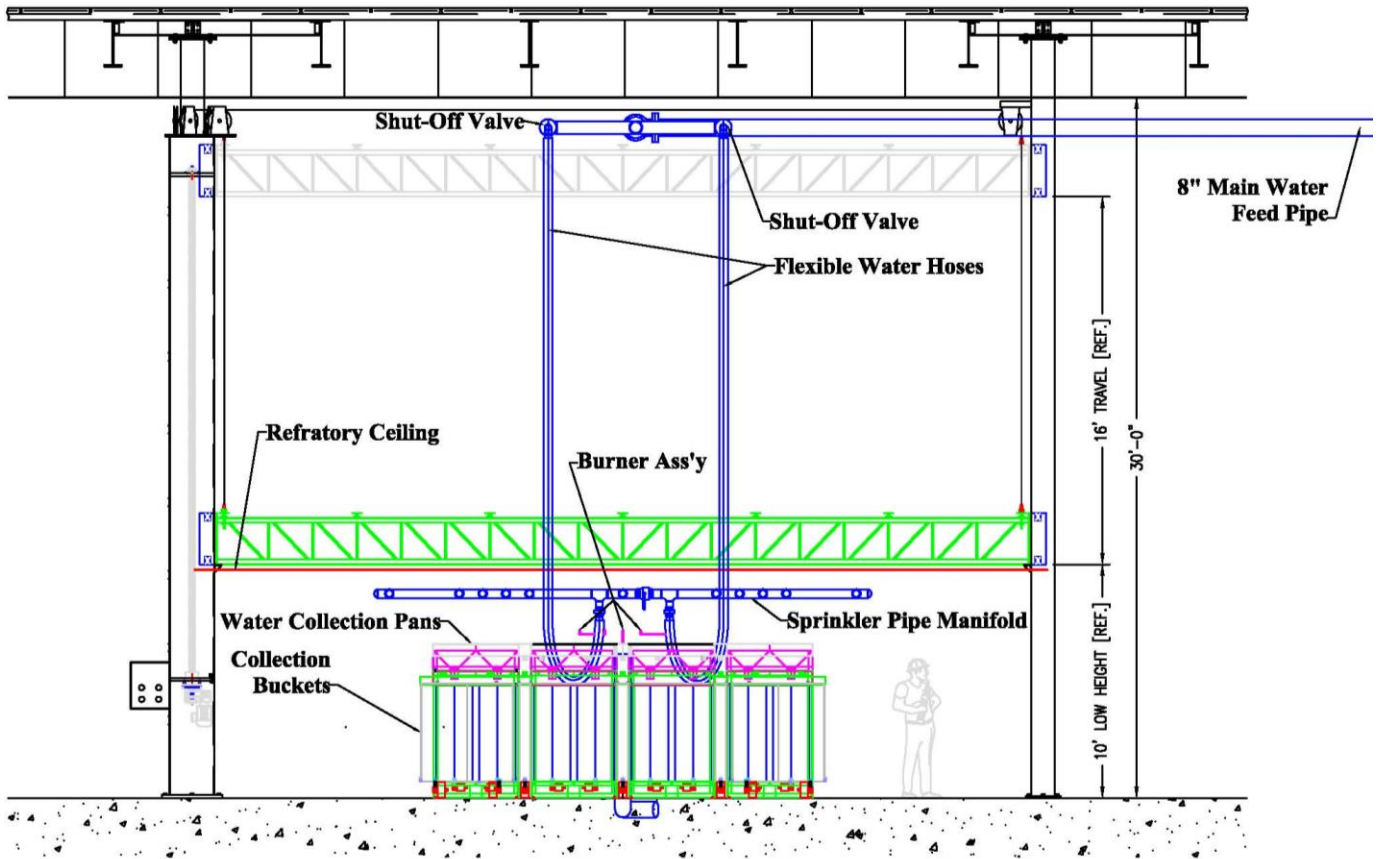

D-20: Actual Delivered Density (ADD) Apparatus – Elevation View

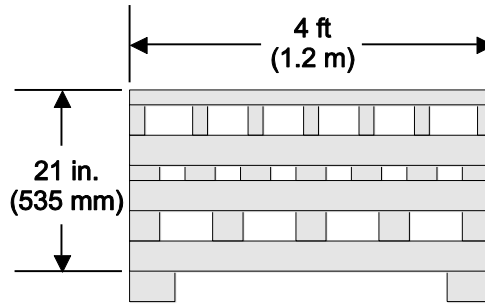

END VIEW

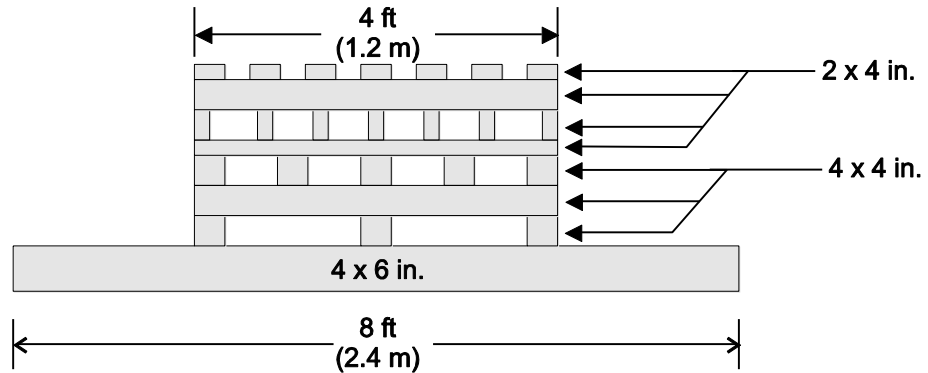

SIDE VIEW

Note: All Lumber Sizes Are Nominal

D-21: Crib Fire Test - Design of Standard Crib

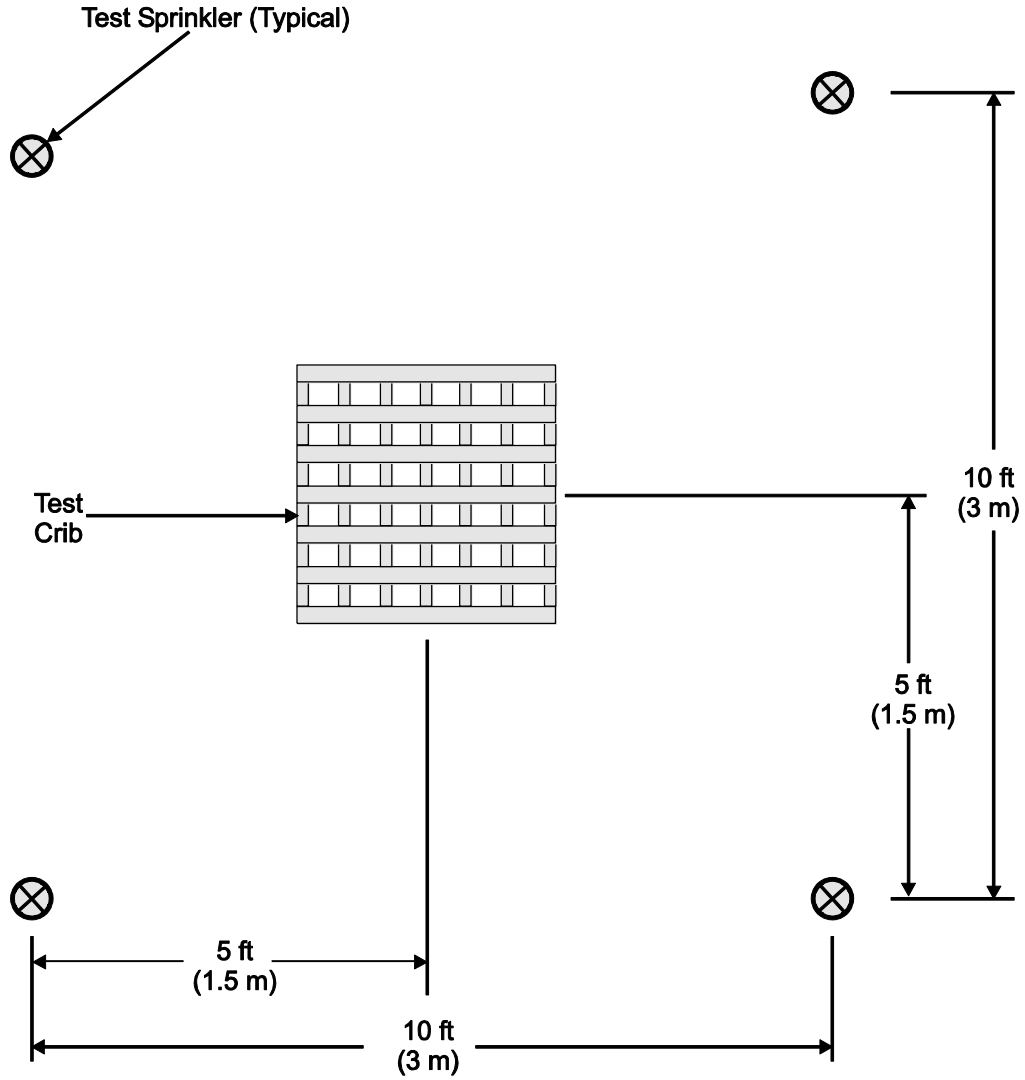

D-22: Crib Fire Test - Sprinkler Position with Respect to Crib

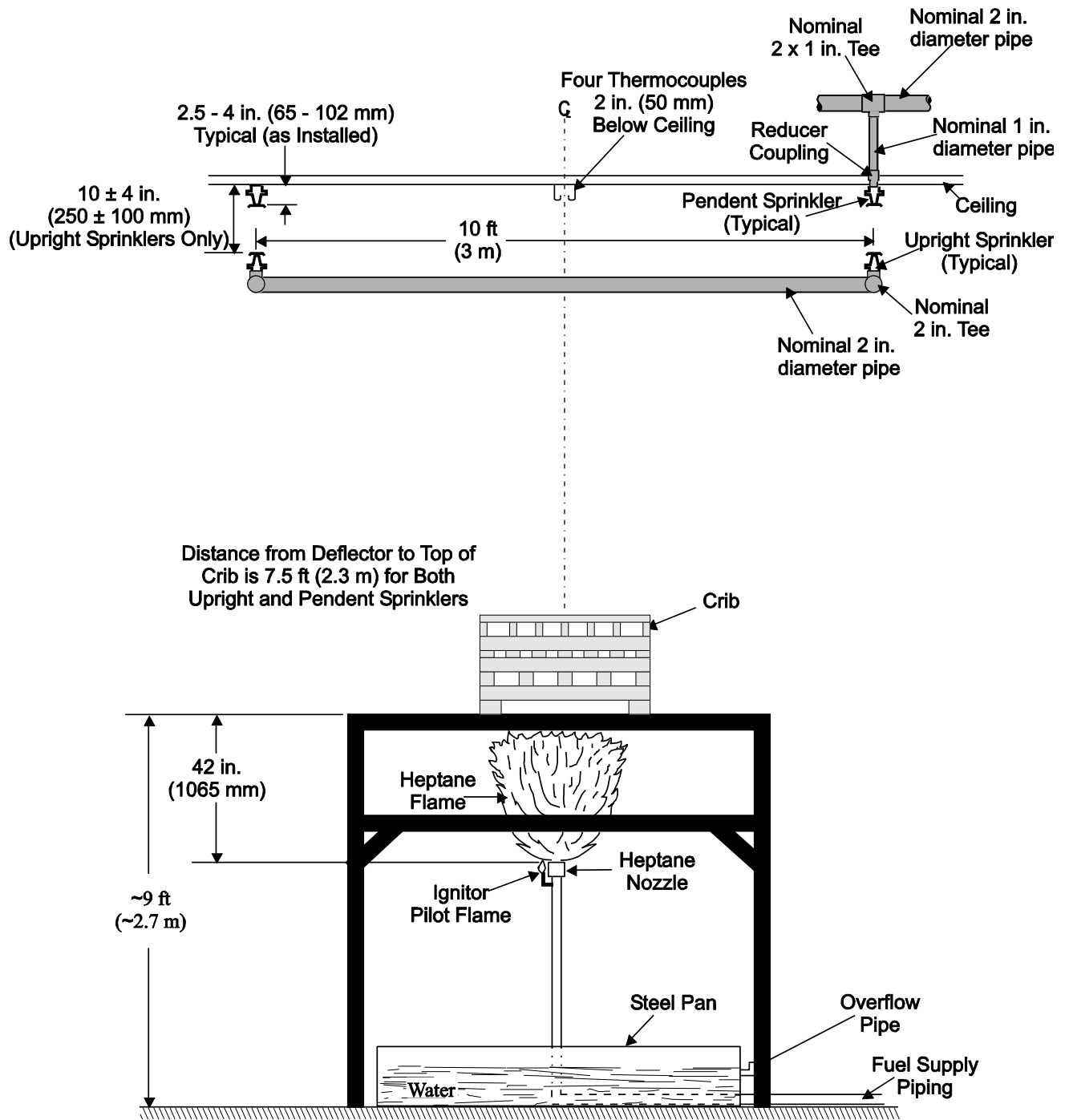

D-23: Crib Fire Test - Arrangement with Piping

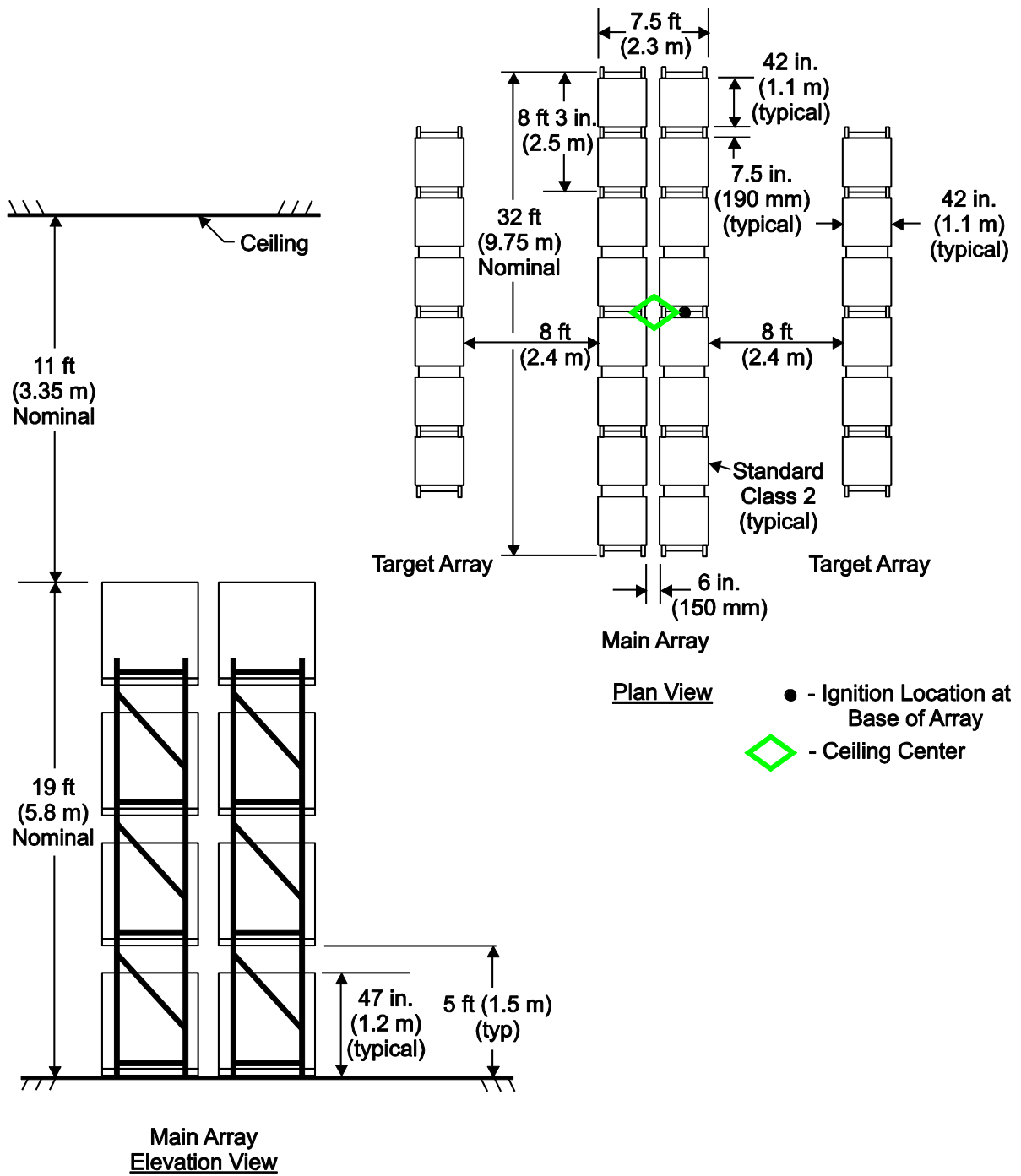

D-24: Full Scale Fire Test Array for K11.2 (K160) and K14.0 (K200) Upright and Pendent Storage Sprinklers, Test A

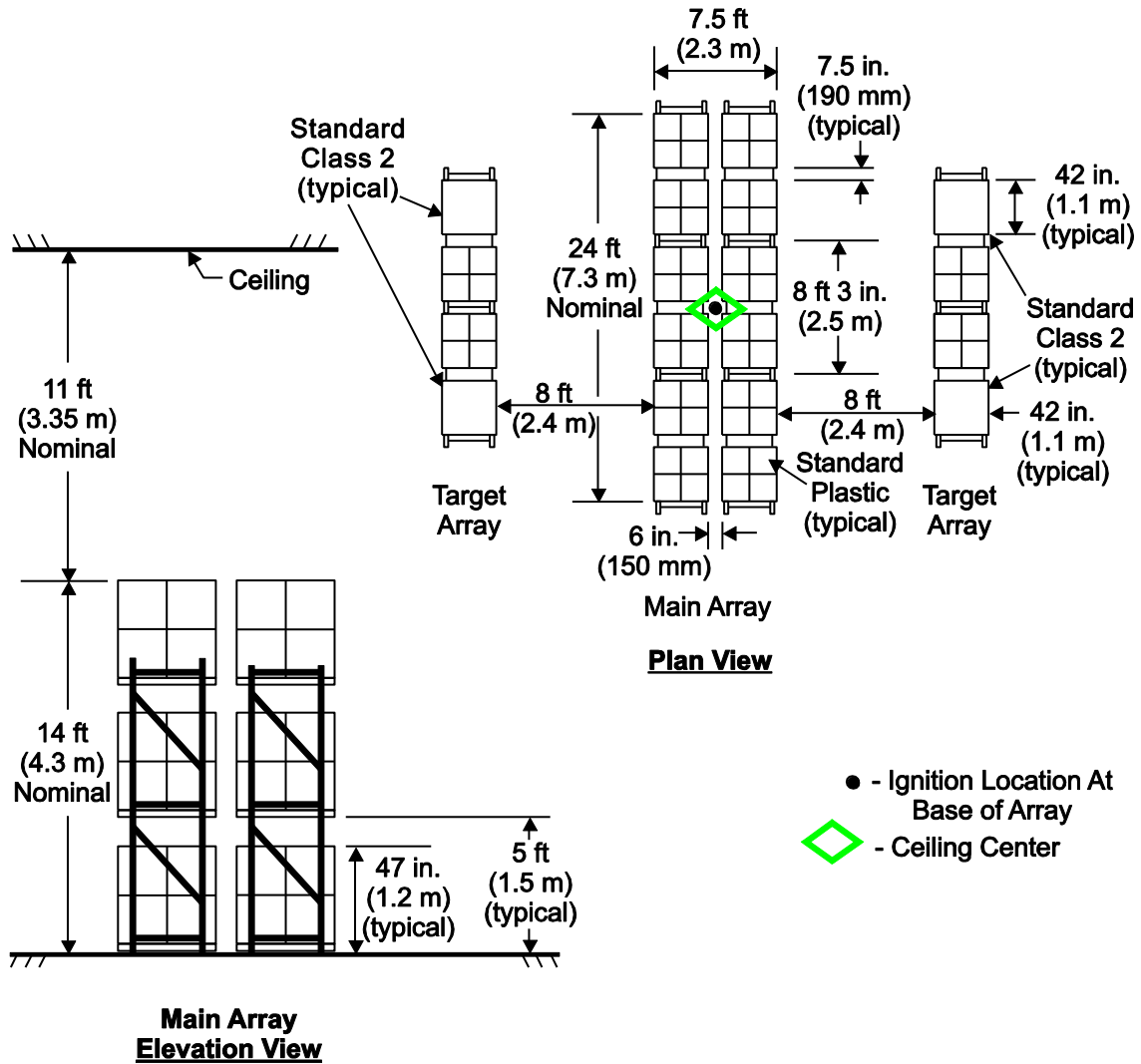

D-25: Full Scale Fire Test Array for K11.2 (K160) and K14.0 (K200) Upright and Pendent Storage, Test B

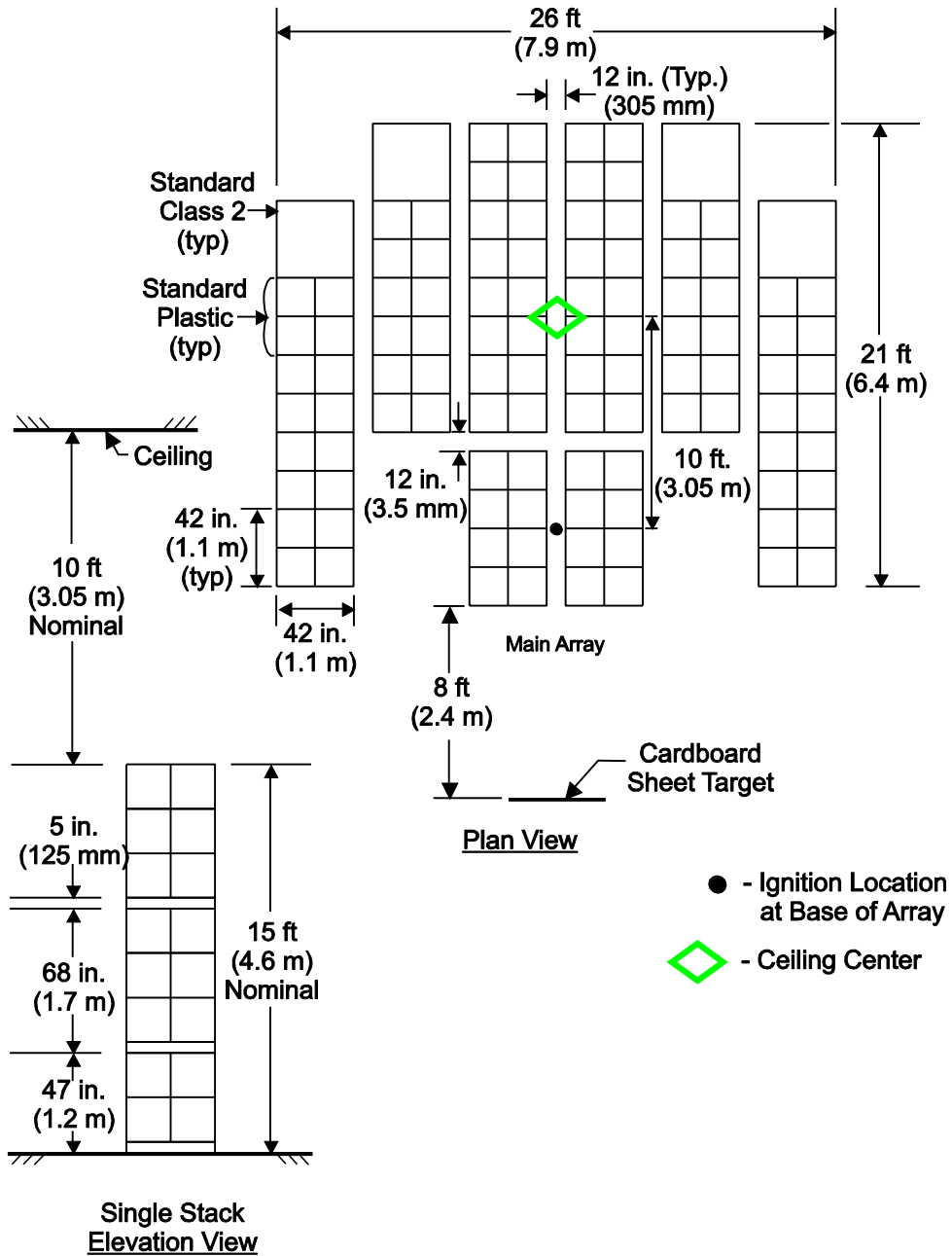

D-26: Full Scale Fire Test Array for K14.0 (K200) Upright and Pendent Storage Sprinklers, Test C

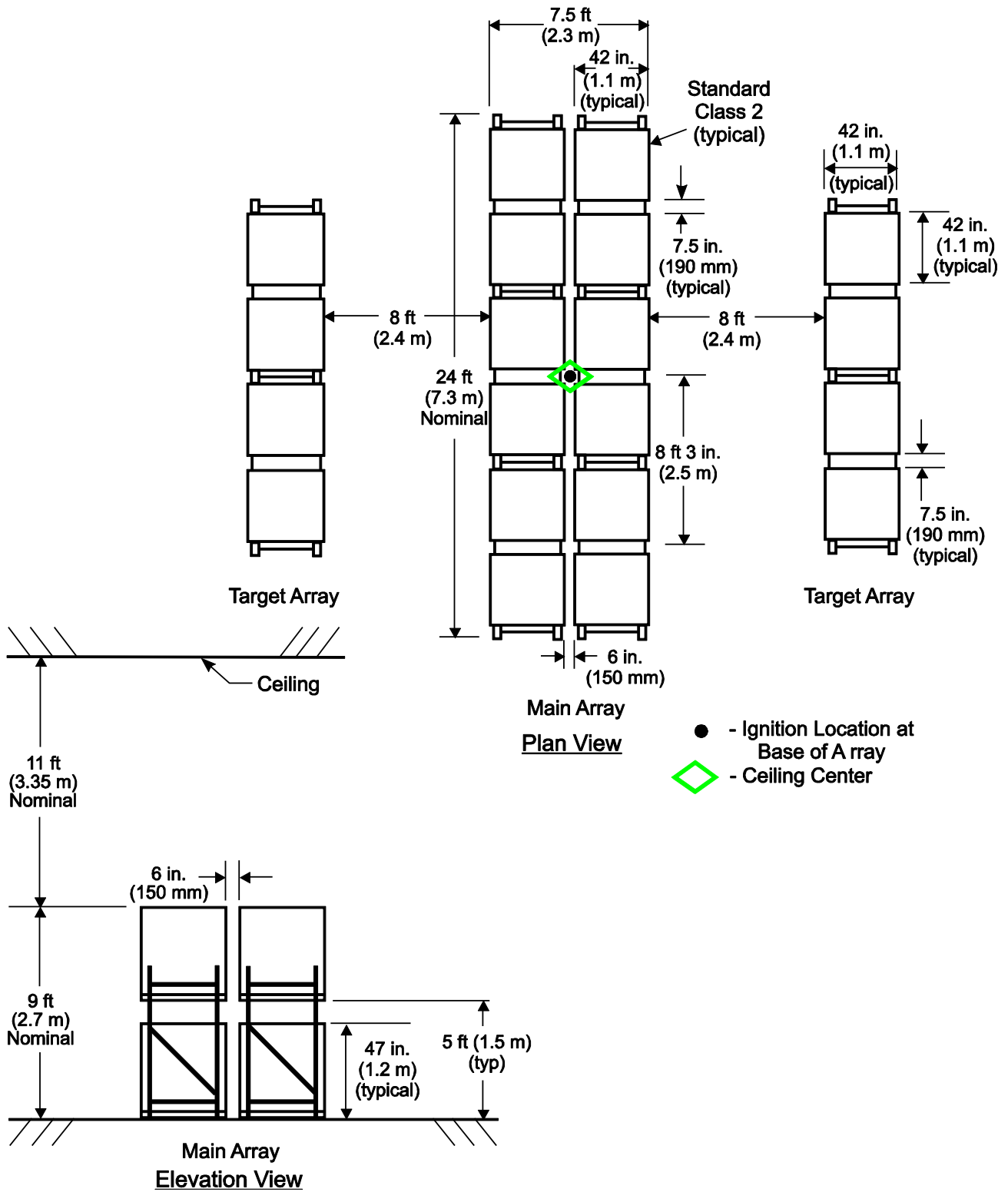

D-27: Full Scale Fire Test Array for K14.0 (K200) Extended Coverage Hazard Category 1-3 Sprinkler

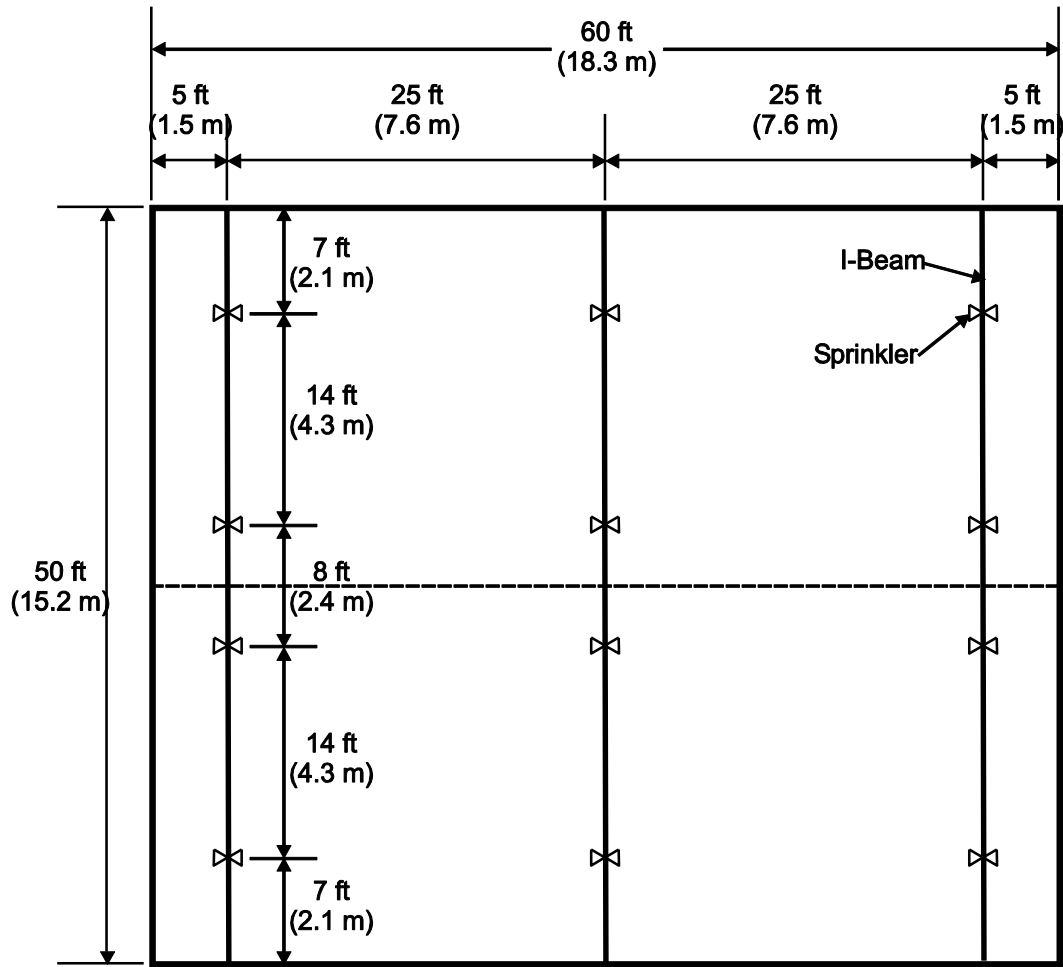

D-28: Sprinkler System Layout - K14.0 (K200) Non-Storage Extended Coverage Horizontal Sidewall Sprinkler

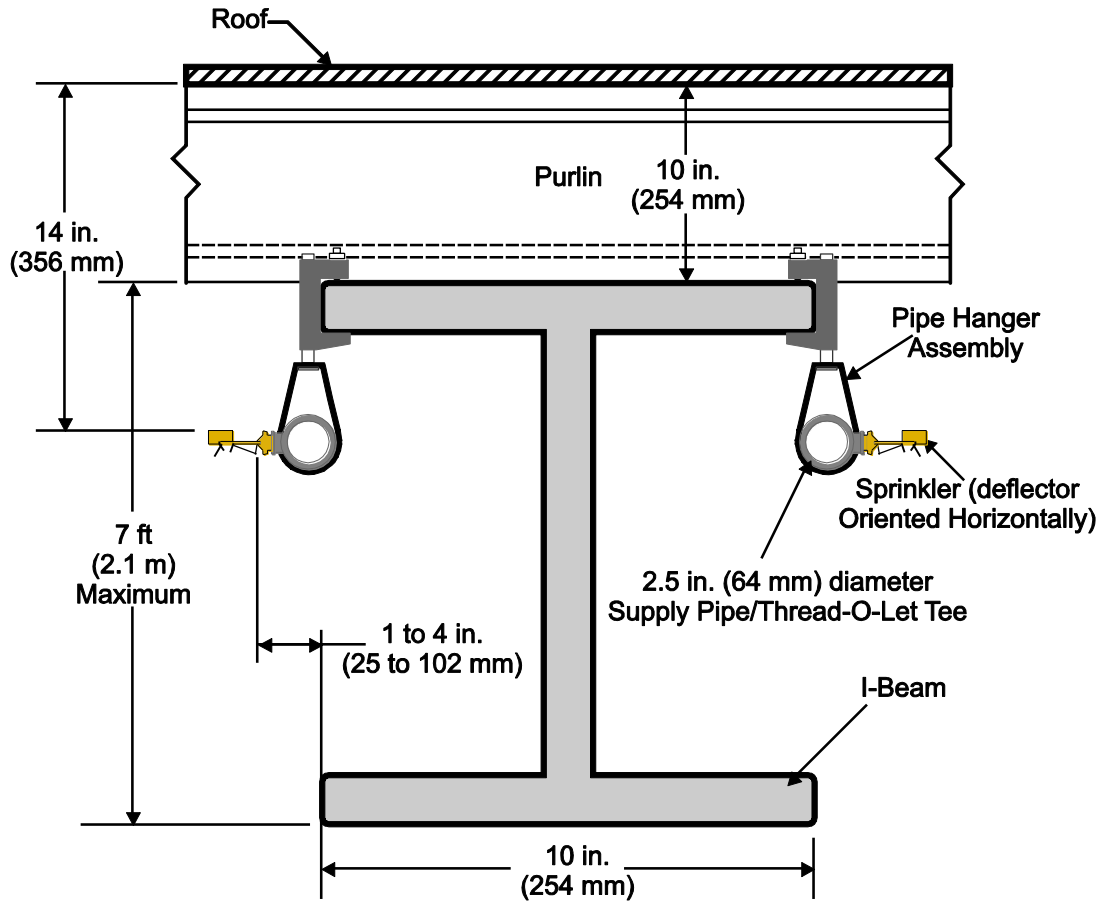

D-29: Sprinkler Installation Position K14.0 (K200) Non-Storage Extended Coverage Horizontal Sidewall Sprinkler

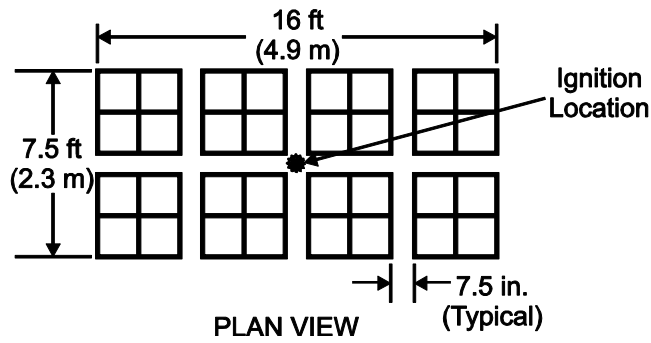
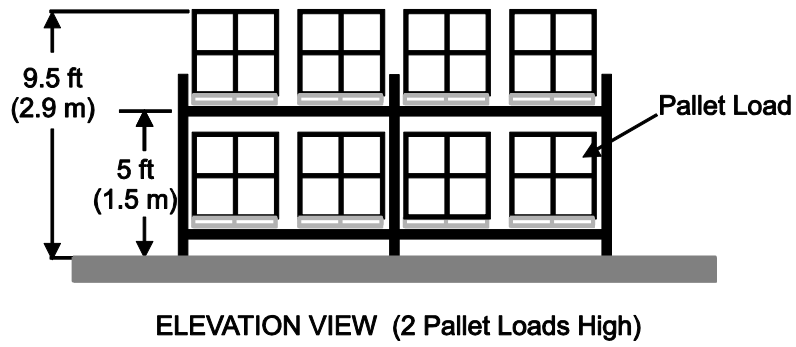
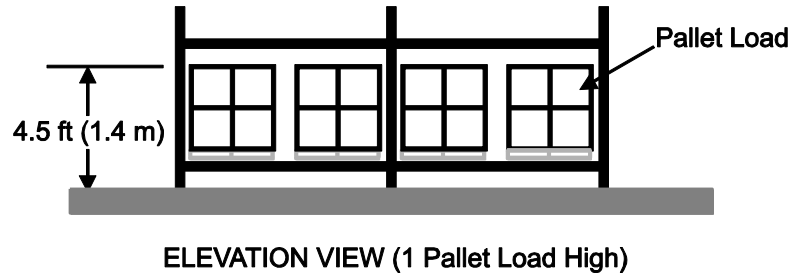

D-30: Full Scale Fire Test Array for K14.0 (K200) Non-Storage Extended Coverage Horizontal Sidewall Sprinkler

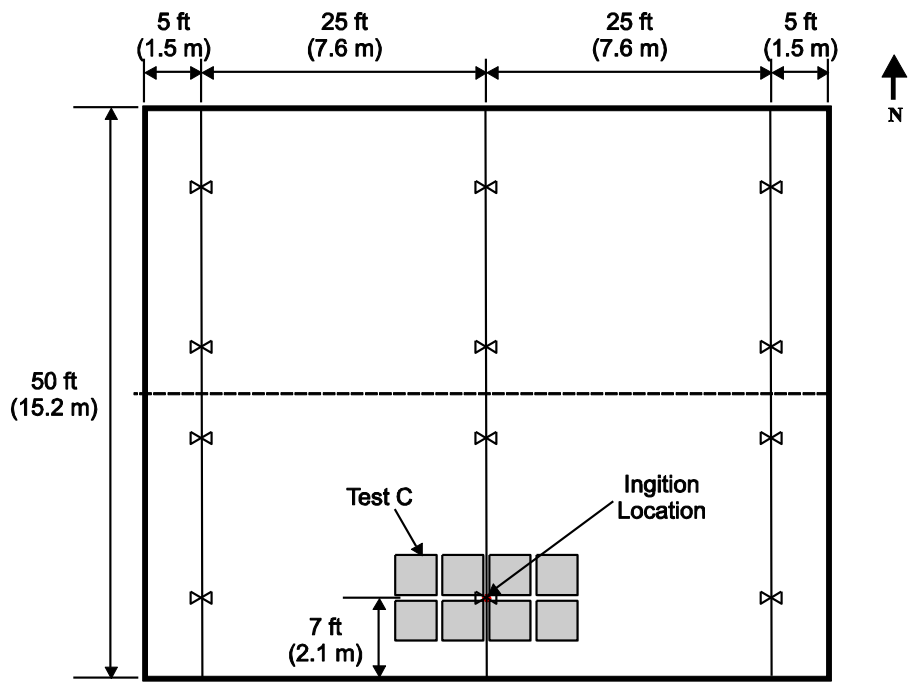
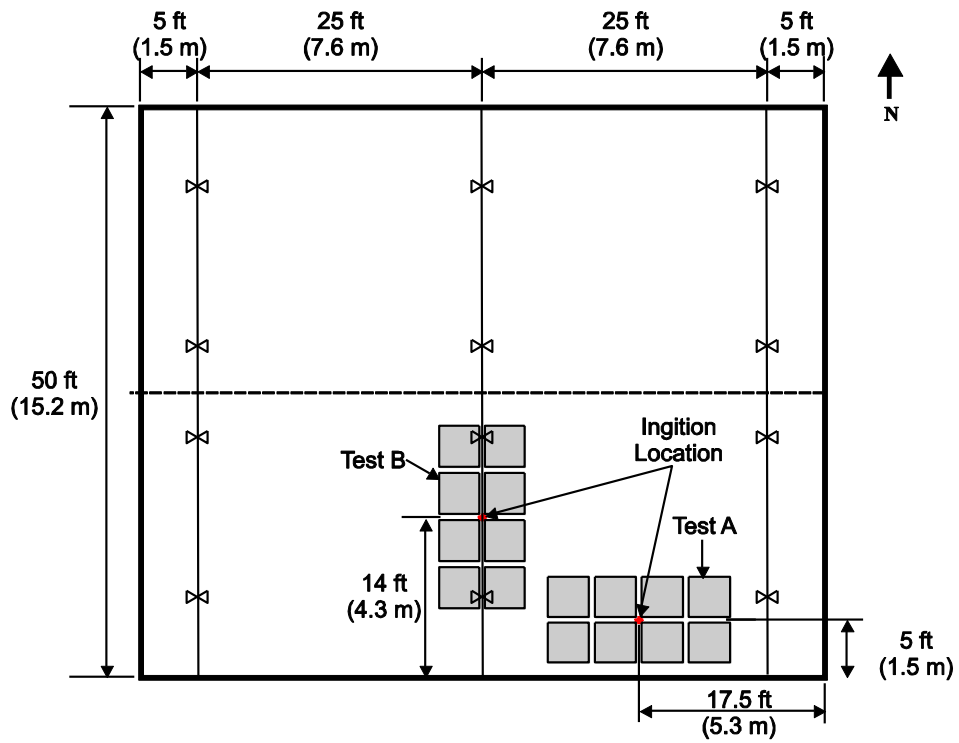

D-31: Array Positions for Screening Tests of K14.0 (K200) Non-Storage Extended Coverage Horizontal Sidewall Sprinkler

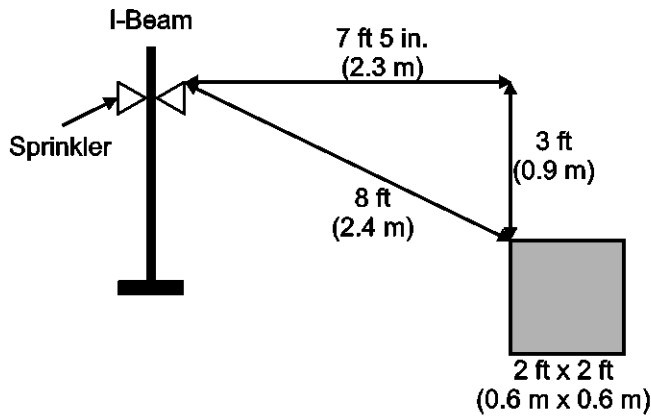

End Elevation View
 2 ft (0.6 m) Wide Obstruction
 8 ft (2.4 m) Separation

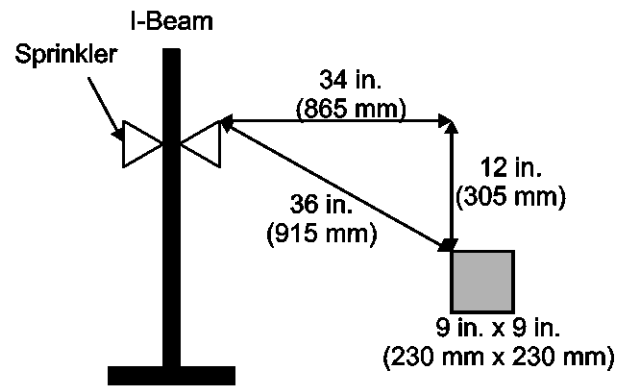

End Elevation View
 9 in. (230 mm) Wide Obstruction
 36 in. (915 mm) Separation

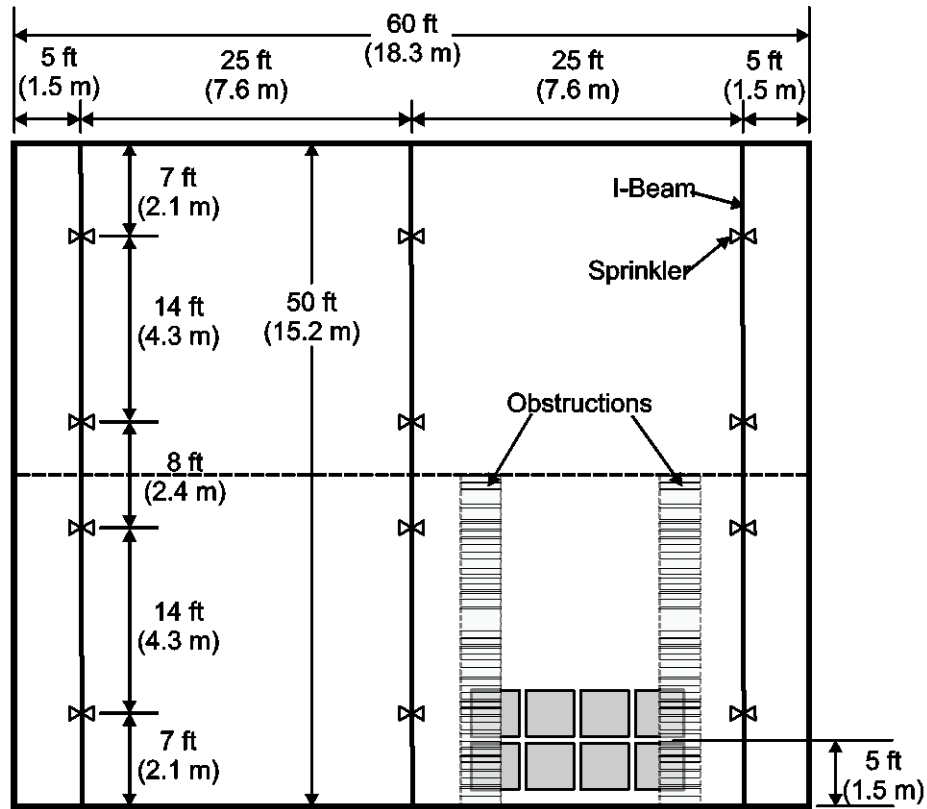

Plan View
 Obstruction Tests A and B

D-32: Obstruction Configuration and Array Position for K14.0 (K200) Non-Storage Extended Coverage Horizontal Sidewall Sprinkler

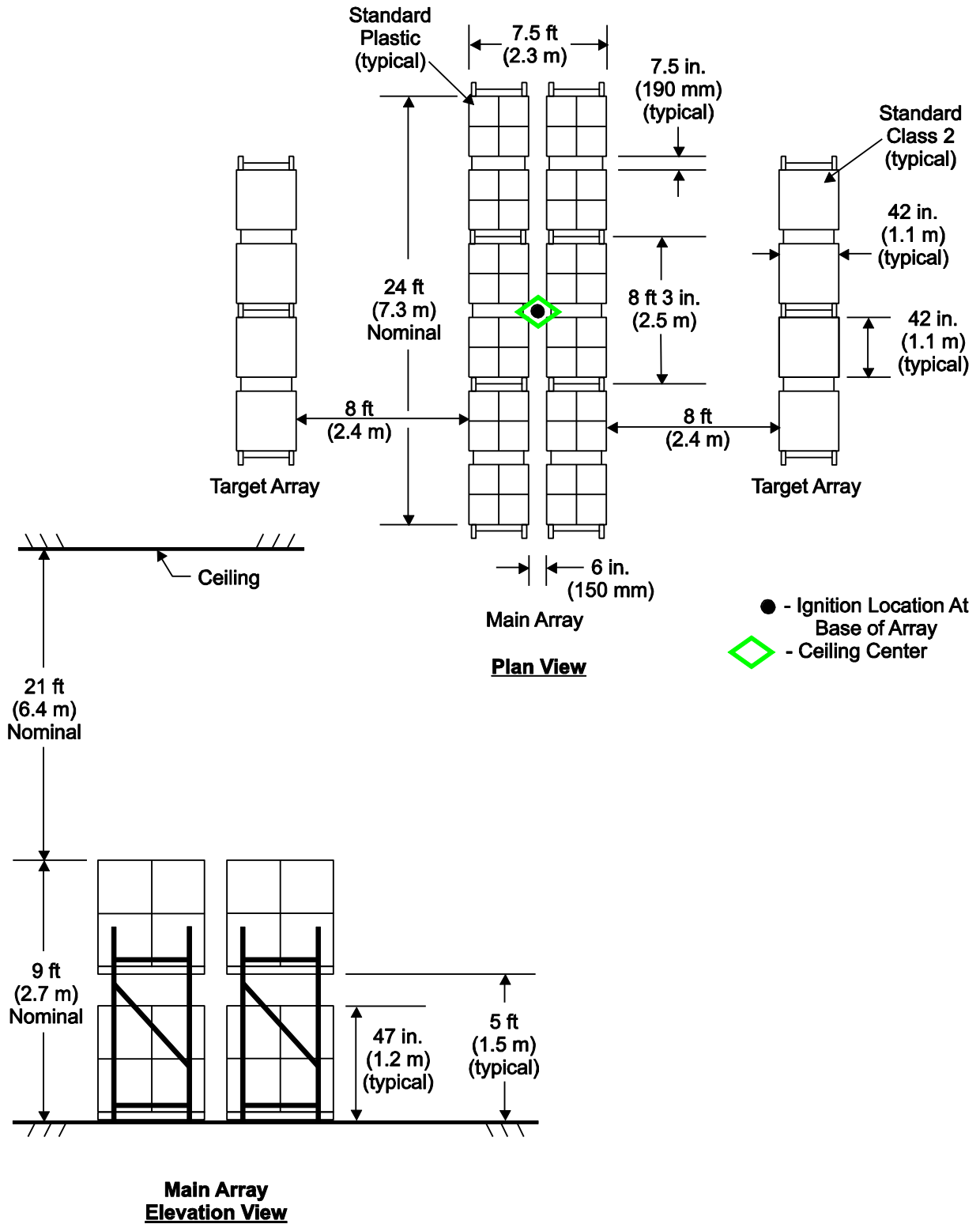

D-33: Full Scale Fire Test Array for K16.8 (K240) Upright Storage Sprinkler, Test A

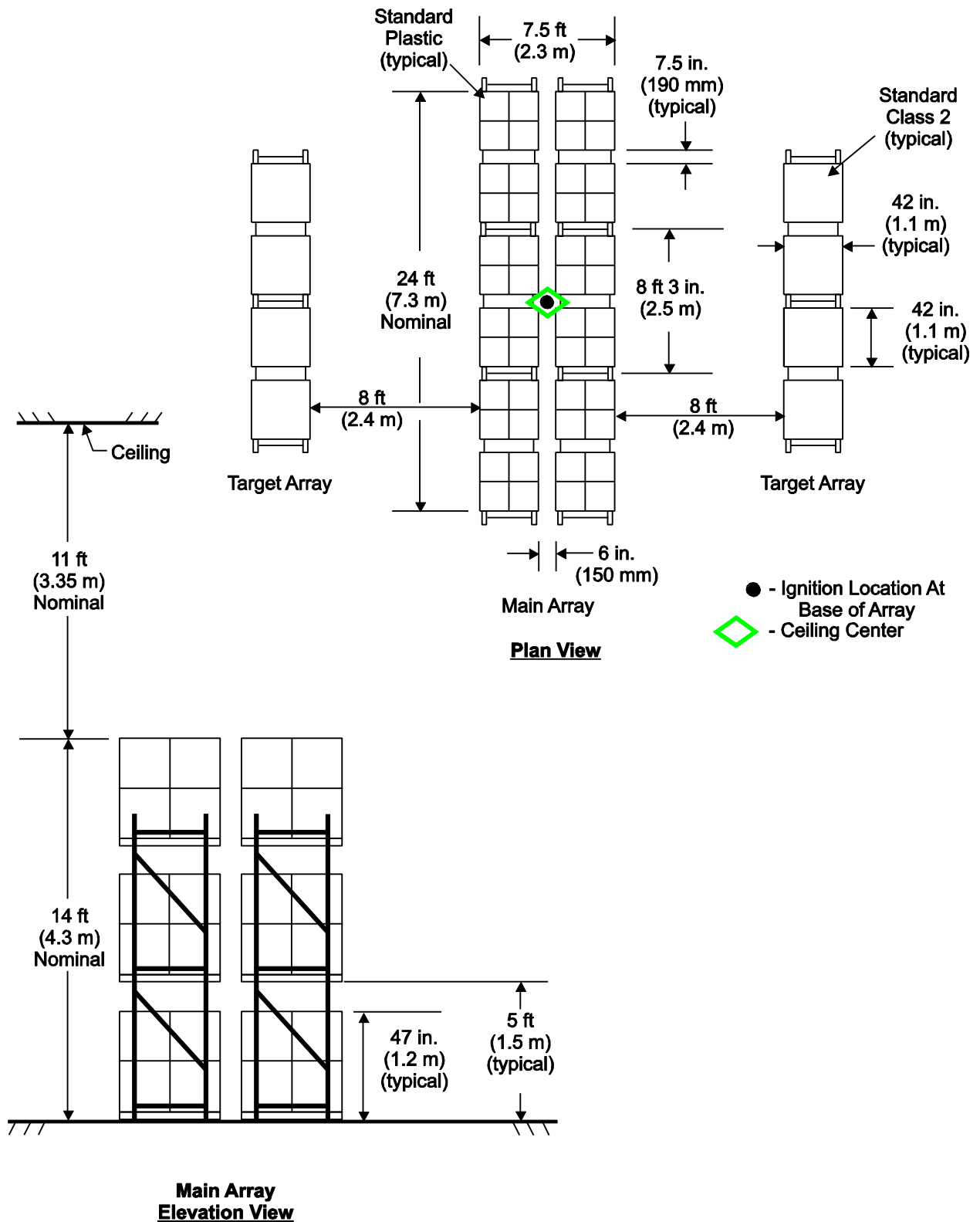

D-34: Full Scale Fire Test Array for K16.8 (K240) Upright Storage Sprinkler, Test B

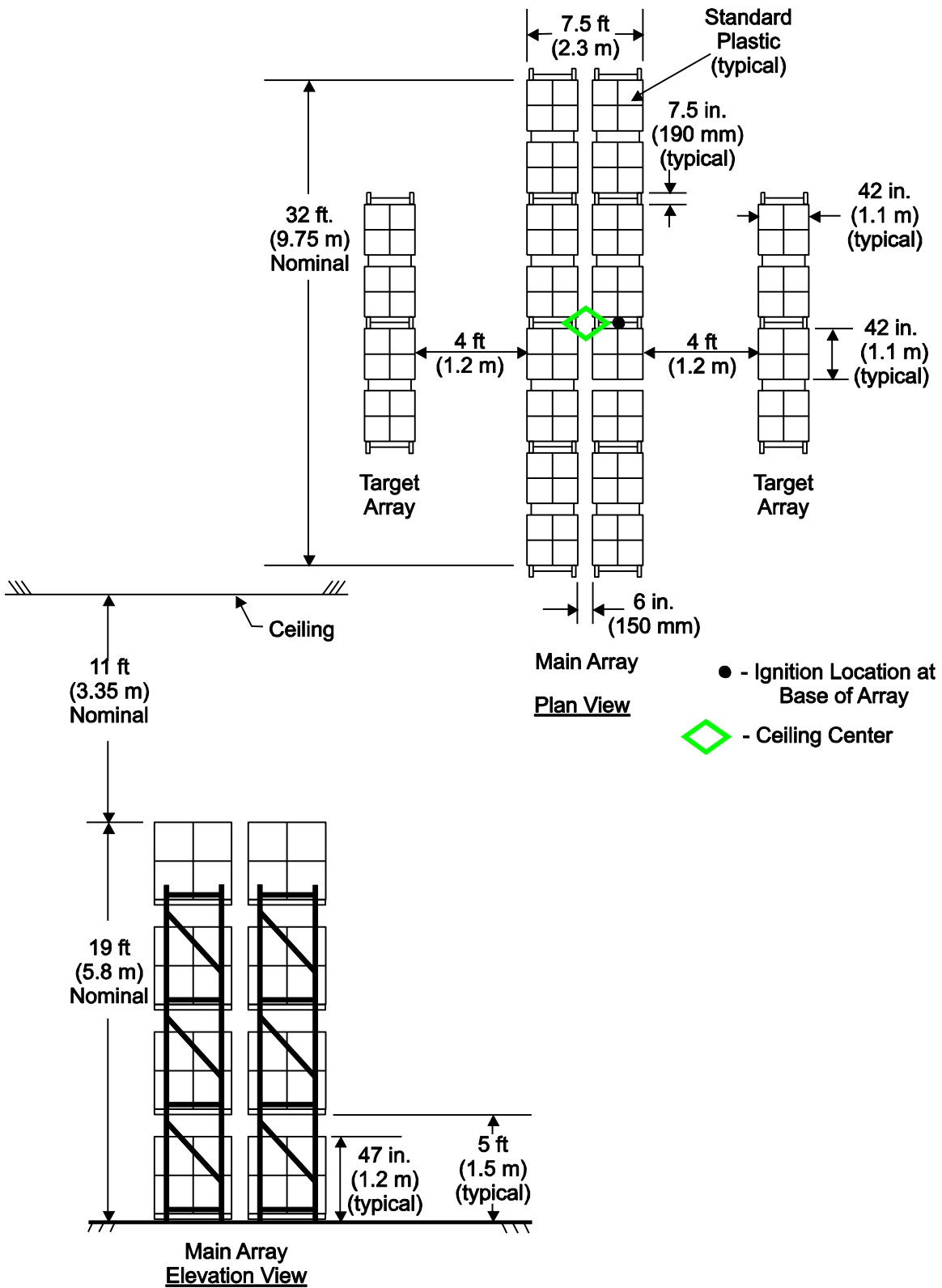

D-35: Full Scale Fire Test Array for K19.6 (K280) Pendent Sprinkler, Test A and B

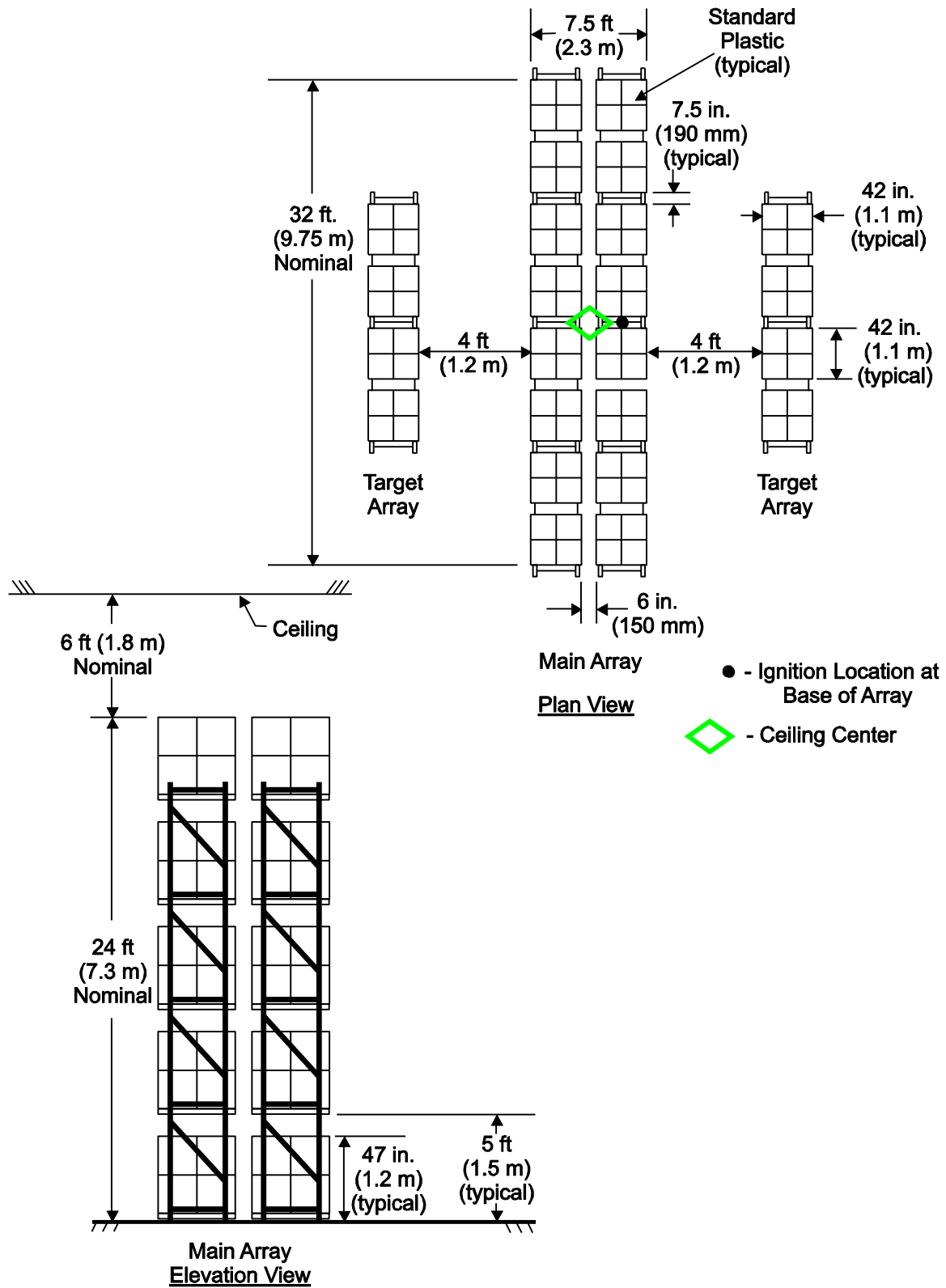

D-36: Full Scale Fire Test Array for K19.6 (K280) Pendent Sprinkler, Test C

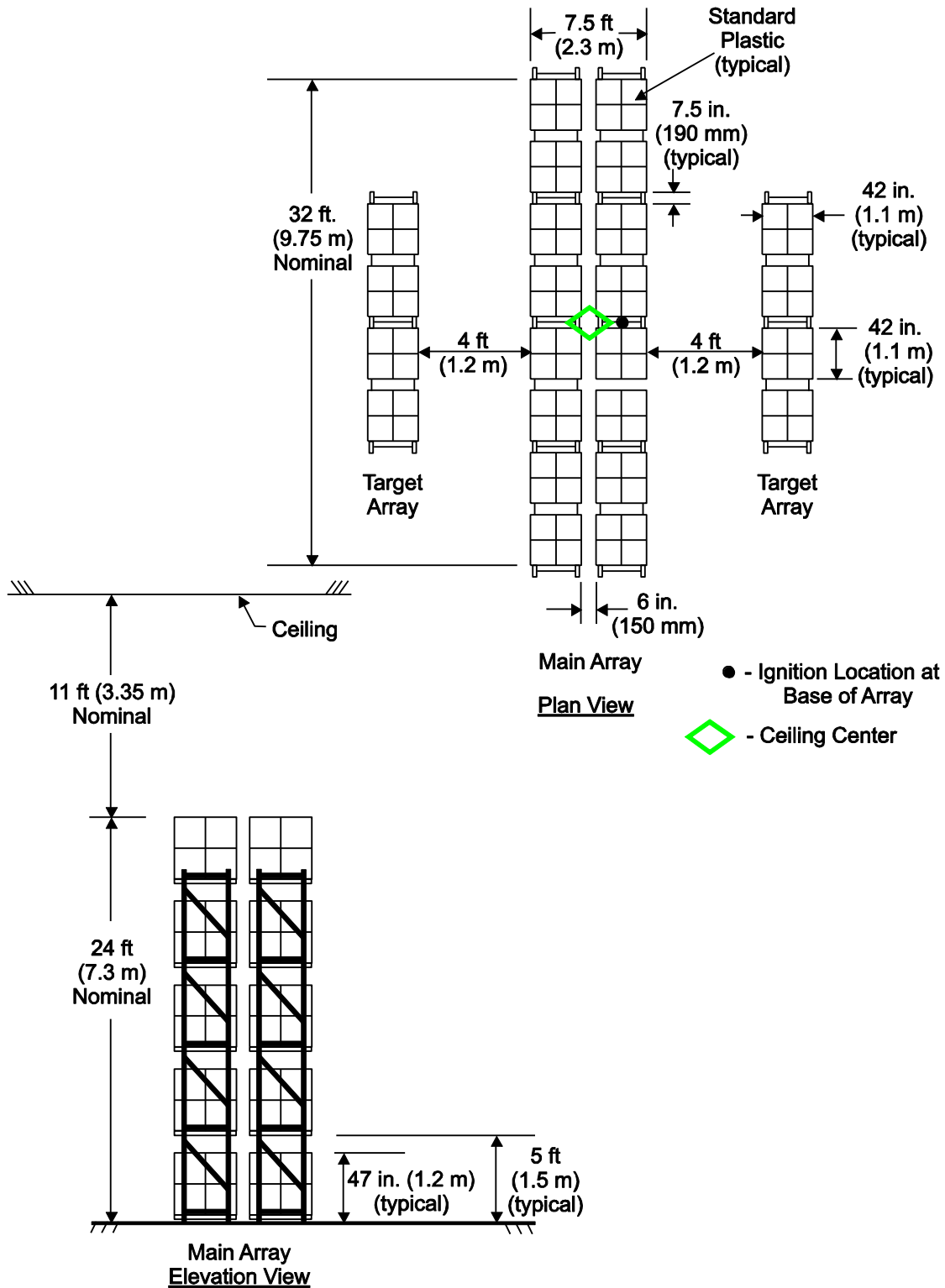

D-37: Full Scale Fire Test Array for K19.6 (K280) Pendent Sprinkler, Test D and E

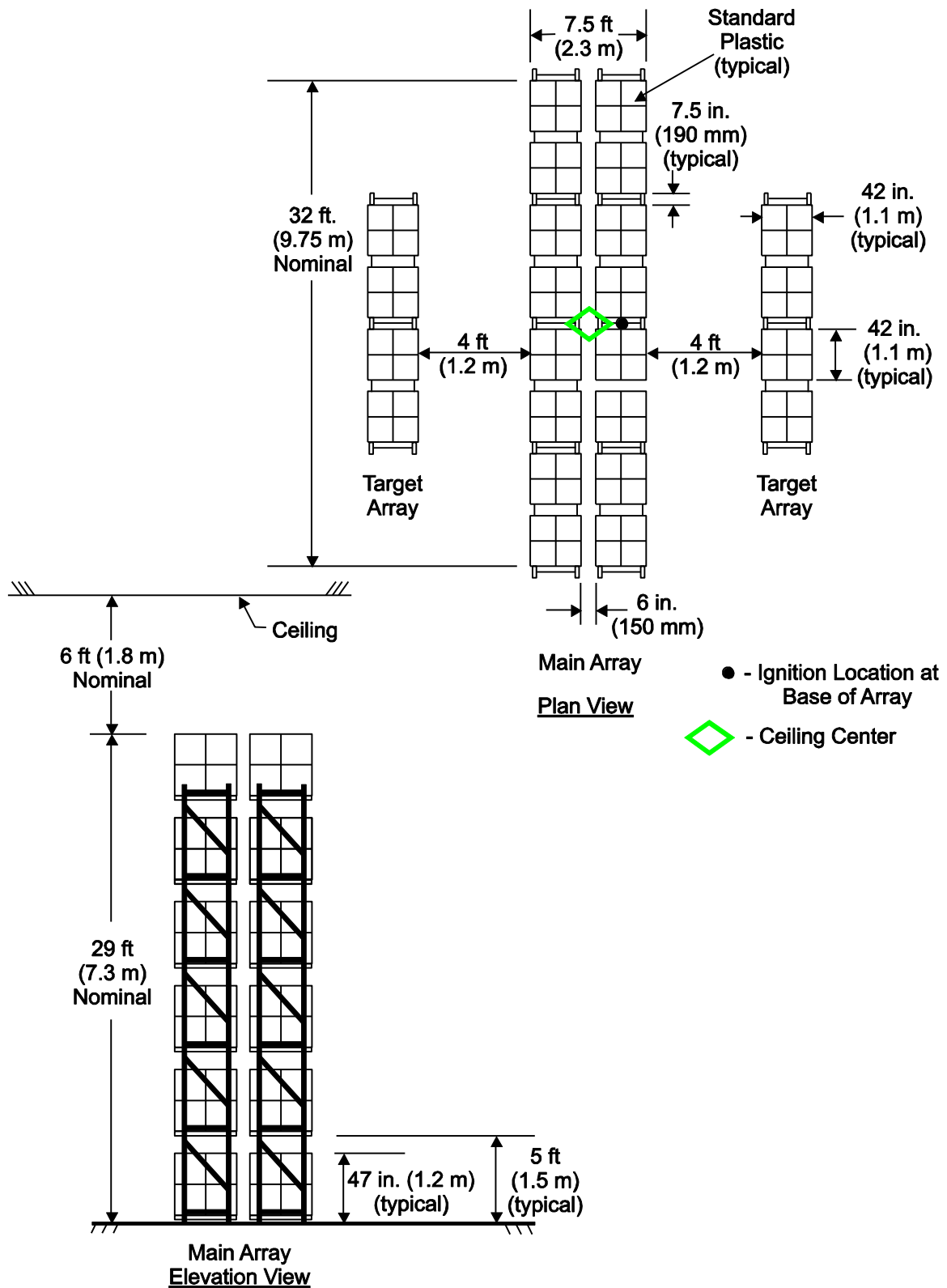

D-38: Full Scale Fire Test Array for K19.6 (K280) Pendent Sprinkler, Test F

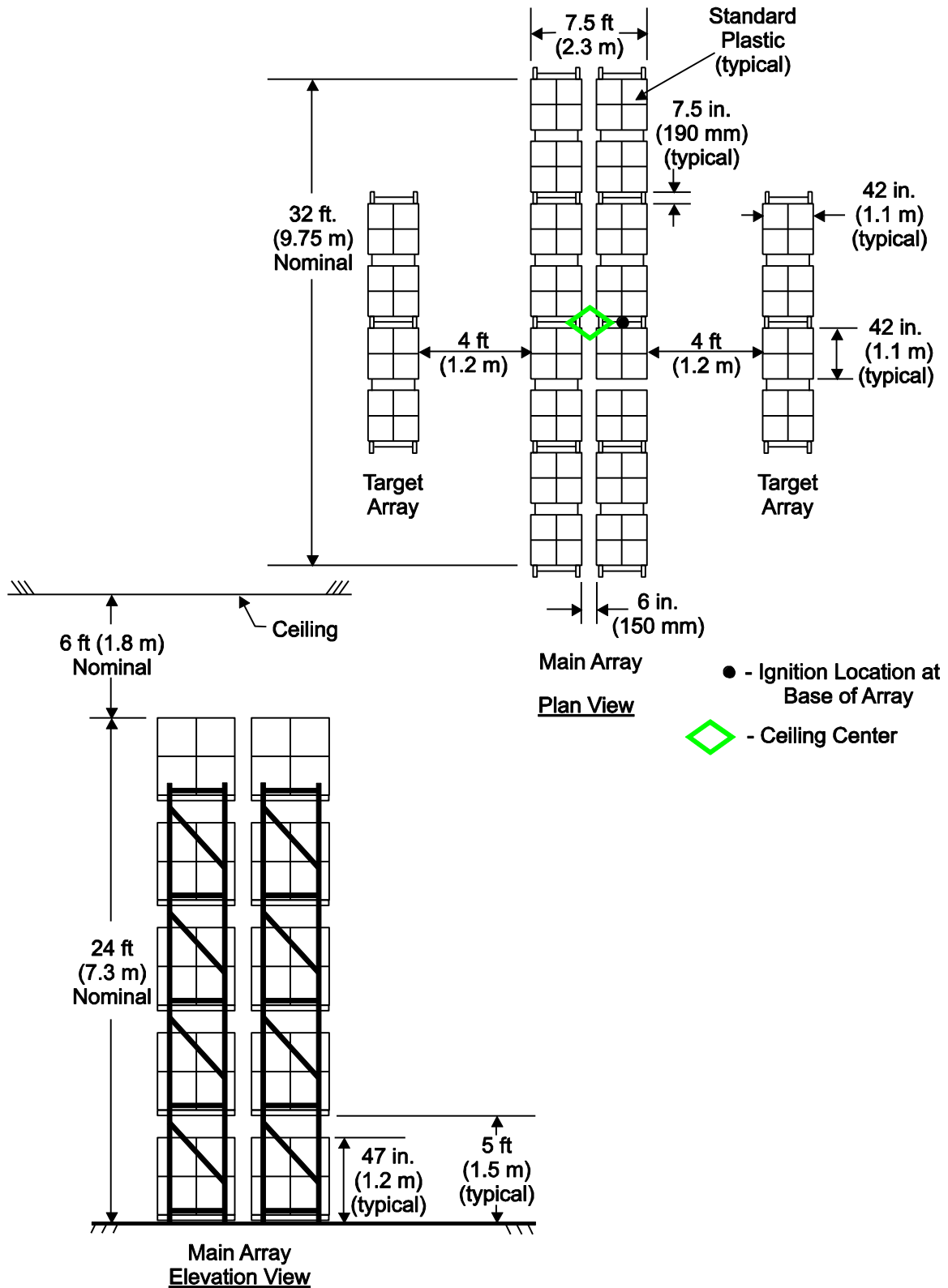

D-39: Full Scale Fire Test Array for K25.2 (K360) Upright and Pendent Sprinklers, Test A

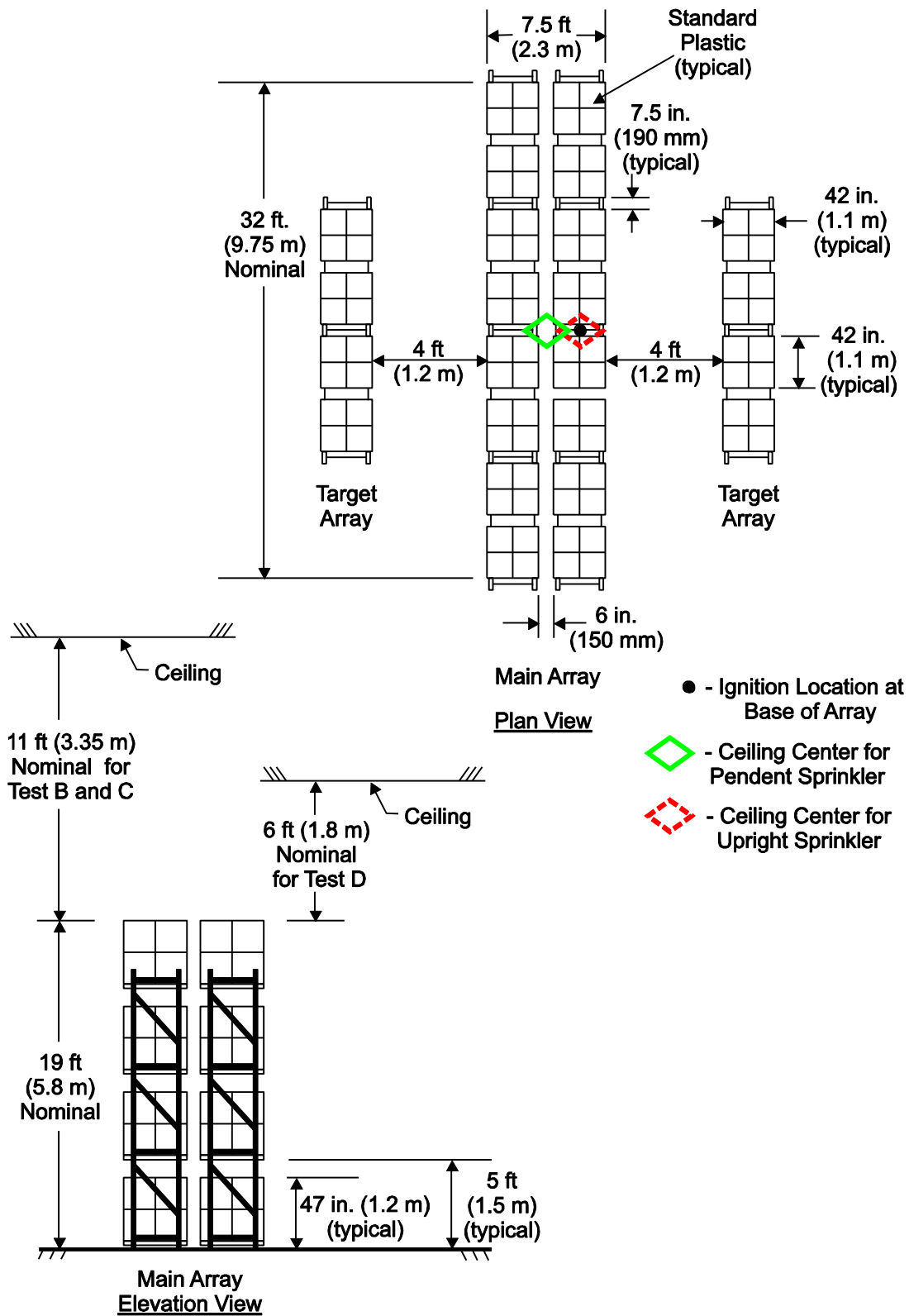

D-40: Full Scale Fire Test Array for K25.2 (K360) Upright and Pendent Sprinklers, Test B and C

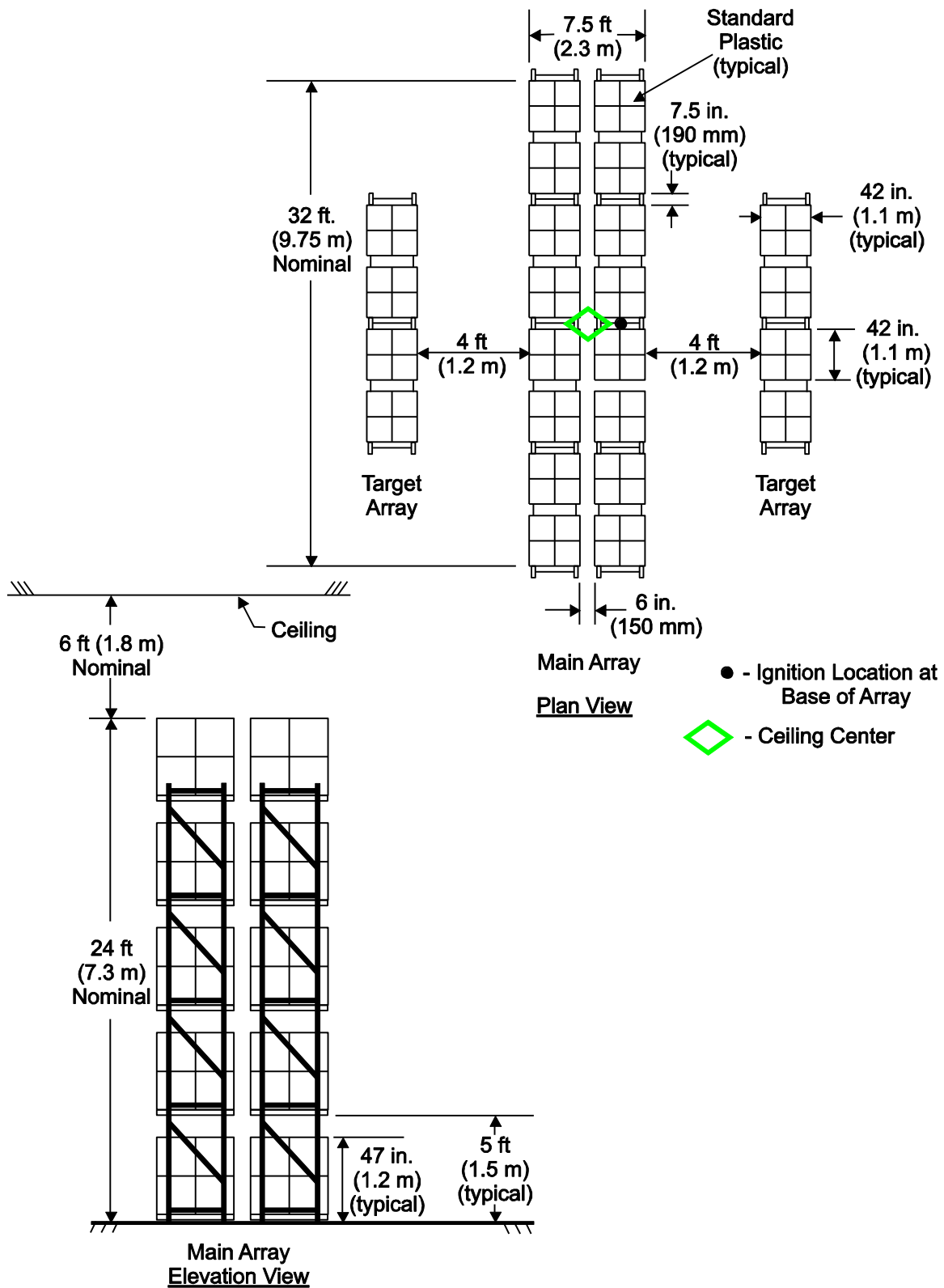

D-41: Full Scale Fire Test Array for K25.2 EC (K360EC) Upright and Pendent Sprinklers, Test A

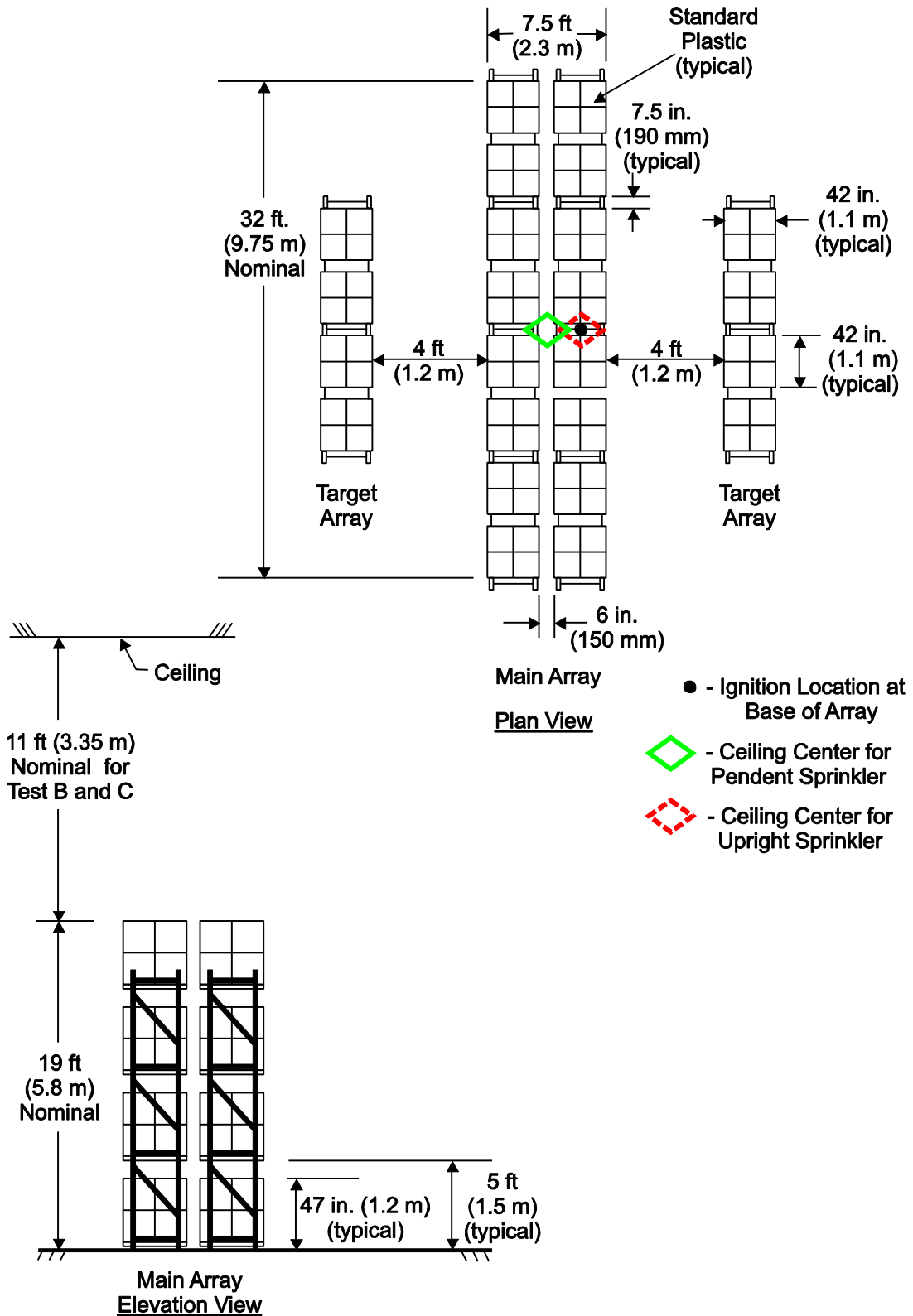

D-42: Full Scale Fire Test Array for K25.2 EC (K360EC) Upright and Pendent Sprinklers, Test B and C

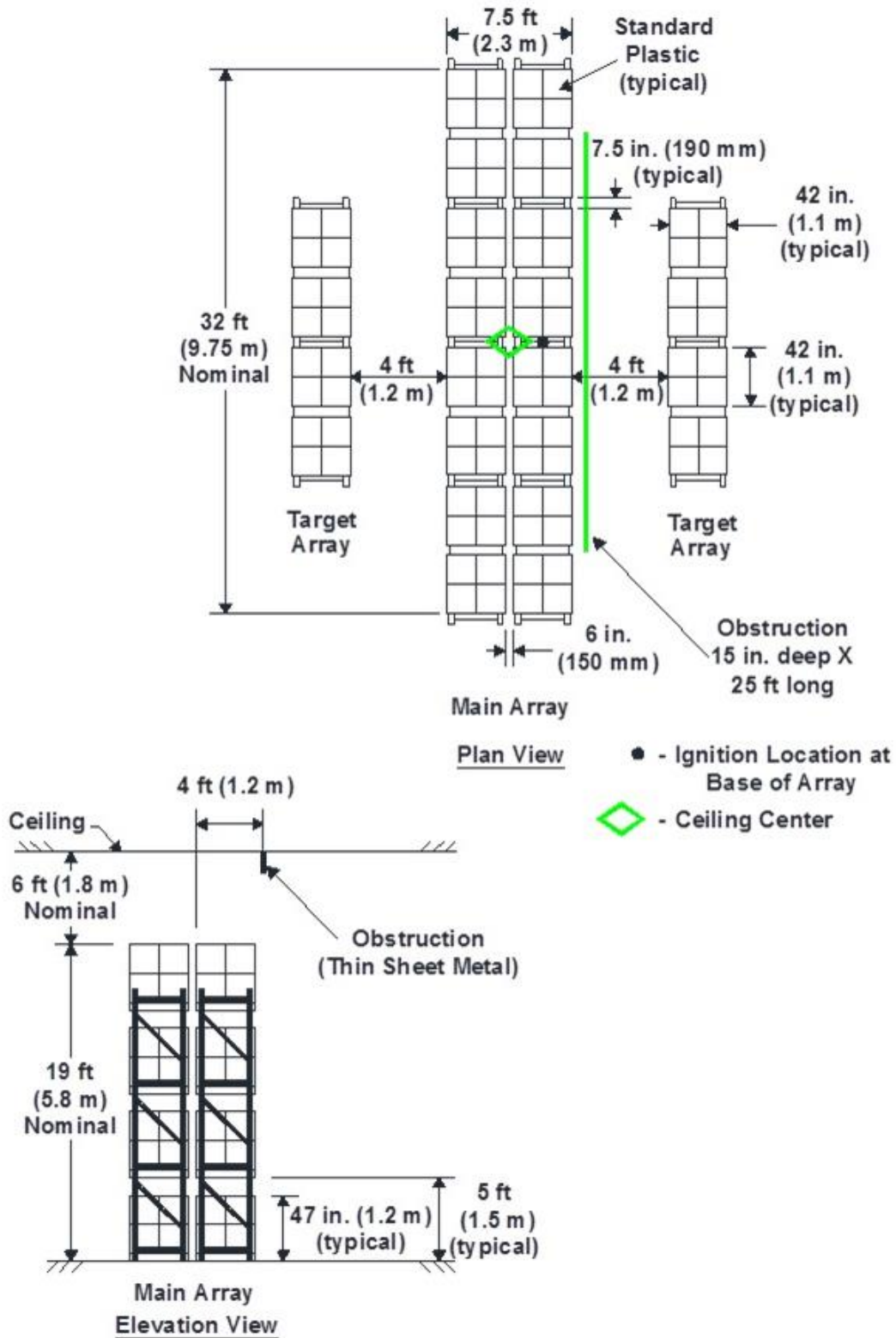

D-43: Full Scale Fire Test Array for K25.2 EC (K360EC) Upright and Pendent Sprinklers, Test D

APPENDIX E: SAMPLE LISTING

K5.6 Upright (Class 2016)

<i>Company</i>	<i>Model</i>	<i>K</i>	<i>Type</i>	<i>Response</i>	<i>Element</i>	<i>NPT (in.)</i>	<i>Finishes</i>	<i>Temp Ratings °F (°C)</i>
ABC	ABC2	5.6	Upright	SR	5 mm	1/2	Brass, Chrome, Polyester	135°, 155°, 175°, 200°, 286°F (57°, 68°, 79°, 93°, 141°C)
PQR	PQR56	5.6	Upright	SR	5 mm	1/2	Brass, Chrome	135°, 155°, 175°, 200°, 286°, 360°F (57°, 68°, 79°, 93°, 141°, 182°C)
WXY	P	5.6	Upright	SR	5 mm	1/2	Brass, Chrome, Polyester, Bright Brass	135°, 155°, 175°, 200°, 286°, 360°F (57°, 68°, 79°, 93°, 141°, 182°C)
XYZ	XZ445 6	5.6	Upright	SR	5 mm	1/2	Wax, Lead, Wax Over Lead	135°, 155°, 175°, 200°F (57°, 68°, 79°, 93°C)